

Lockheed Aircraft Divison
Georgia Division

ER-4112

C-130
Fulton Skyhook
Aerial Recovery System

Circa 1960

(Also later known as the Fulton STAR – Surface-To-Air-Recovery – System.)

2-8-60

ER-4112

C-130
FULTON SKYHOOK
AERIAL RECOVERY SYSTEM

Prepared By: Engineering Branch

APPROVED:



A. E. Flock
Chief Engineer

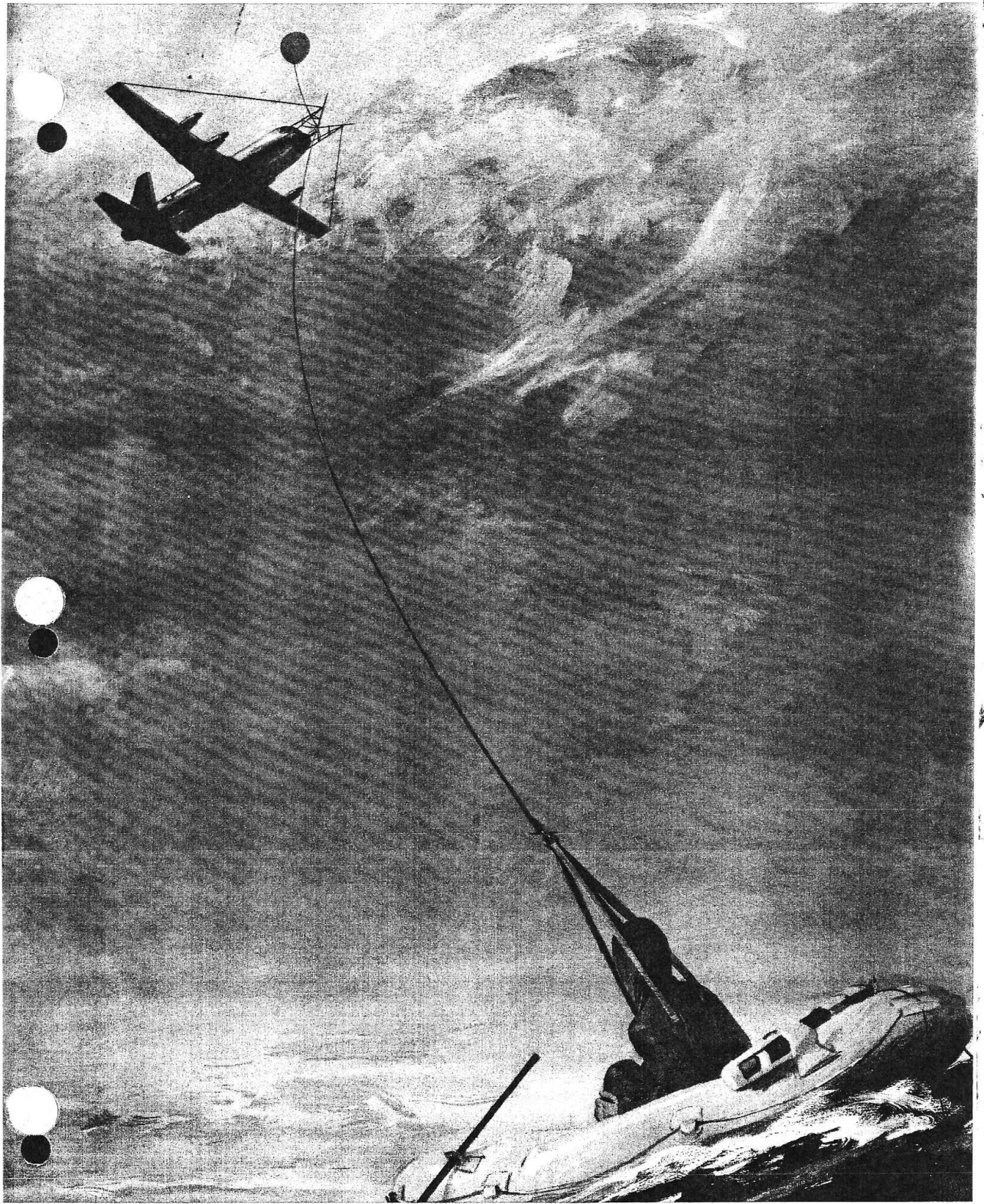

PREFACE

This report, an unsolicited preliminary design study of the installation of the Fulton Skyhook Aerial Recovery System to the C-130 series aircraft, includes a brief description and history of the Fulton Skyhook System together with a description of the equipment installation on the C-130 and the recommended recovery system operation.

References, when used, are listed in the back of the report.

CONTENTS

<u>Section</u>	<u>Title</u>	<u>Page</u>
	FRONTISPIECE	i
	PREFACE	ii
	FIGURE INDEX	iv
I	SUMMARY	1
II	INTRODUCTION	14
III	FULTON SKYHOOK SYSTEM	15
	Historical Note	15
IV	SYSTEM APPLICATION	19
V	RECOVERY SYTEM OPERATION	52
	REFERENCES	72

FIGURE INDEX

<u>Figure</u>	<u>Title</u>	<u>Page</u>
1	Inboard Profile C-130B Fulton Skyhook Aerial Recovery System	2 & 20
2	C-130 Aerial Recovery System Time On Station Vs Mission	7 & 53
3	Retrieving Equipment - Hoisting Survivor Aboard	10 & 63
4	Acceleration Profiles	13 & 67
5	Fulton Skyhook System	16
6	General Arrangement - Fulton Skyhook Aerial Recovery System C-130	23
7	Installation - Skyhook and Yoke	24
8	Installation - Guard Cable-Wing Tip	27
9	Comparison - Fulton Skyhook System P2V Vs C-130B	28
10	Assembly and Installation - Pallet	30
11	Assembly and Installation - Safety Fence	32
12	Pallet Operators - Retrieving Equipment	34
13	Hydraulic Schematic - C-130A	35
14	Hydraulic Schematic - C-130B	36
15	Operating Torque - Input Required Vs Output Available	38

FIGURE INDEX (Cont'd)

<u>Figure</u>	<u>Title</u>	<u>Page</u>
16	Weight Summary	49
17	Center of Gravity Diagram - C-130A	50
18	Center of Gravity Diagram - C-130B	51
19	C-130B Aerial Recovery System Mission Profile - Normal Power	54
20	C-130A and C-130B Stall Speeds - Power Off	56
21	Retrieving Equipment - Initial Attachment	59
22	Pallet Sequence - Step I	60
23	Pallet Sequence - Step II	61
24	Extreme Cold Weather Recovery Windscreen	70

I - SUMMARY

The Fulton Skyhook Aerial Recovery System and its operational technique have been developed for in-flight pickup of men and materials with high performance aircraft. It has been operationally proven with tests utilizing a Lockheed P2V and conducted by the Office of Naval Research. The pickup is accomplished by attaching a long nylon line to the payload to be recovered and suspending the line aloft with a balloon. The airplane picks up the payload by flying into the line, which is caught and held by a Skyhook anchoring device. The payload is then winched aboard the airplane.

In this study, the proven Fulton System, with minimum change, is applied to either the C-130A or C-130B aircraft. The basic difference between the P2V and C-130 systems are the retrieving procedures. On the P2V the pickup load is taken in through a hatch in the lower fuselage; on the C-130 it is taken in through the open ramp door.

The equipment, as shown in Figure 1, consists of two basic portions:

1. The pickup equipment located on the nose of the airplane which guides the pickup retrieving cable into the Skyhook anchoring device and
2. The payload retrieving equipment located on a pallet on the aft cargo ramp door. (After the operator picks up the line streaming aft from the nose, this equipment winds in the cable and hoists the payload aboard.)

INBOARD PROFILE C-130B FULL TON
SKYHOOK AERIAL RECOVERY SYSTEM

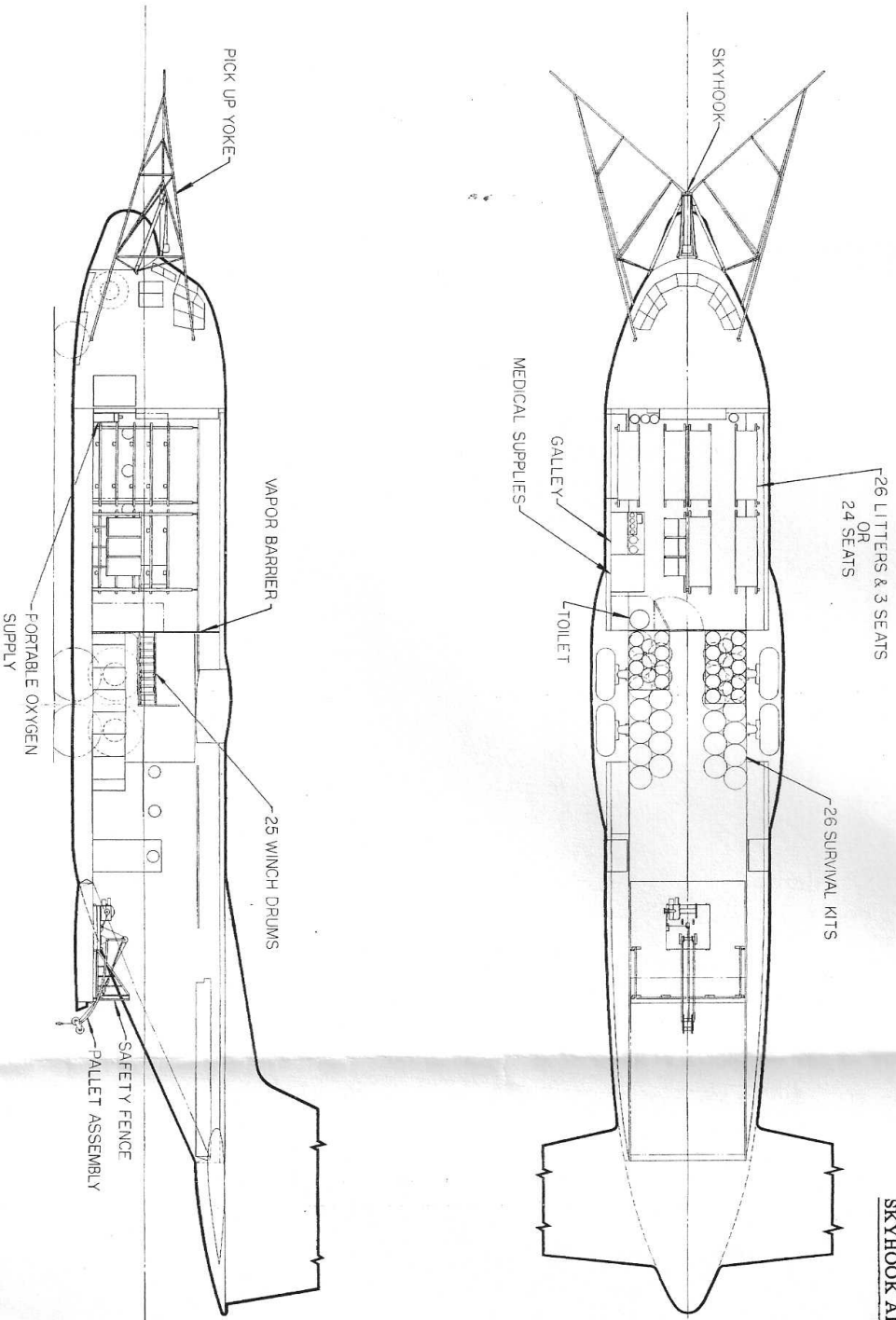

0 30 60 90 120 150
SCALE-INCHES

Provisions for pickup equipment storage and for transport of retrieved personnel are shown in the forward part of the cargo compartment in Figure 1. The extent of these provisions which can be included in the C-130 is typified by this arrangement.

Pickup Equipment

The pickup equipment shown in Figure 1, consists of the yoke and supporting truss, the Skyhook and supporting truss, the propeller guard cables strung between the yoke and the airplane wing tip, and the retriever line deflector cable.

The yoke has a spread of 24 feet to provide ample tolerance when maneuvering the airplane to engage the retrieving line. The yoke guides the retrieving line into the Skyhook which automatically secures the retrieving line to the airplane.

The propeller guard cable protects the propellers from being fouled by the retrieving line, in case the pilot misses the line with the yoke, and deflects the retrieving line around the wing tip.

The retrieving line deflector cable prevents the retrieving line from hanging up on the nose of the radome.

Retrieval Equipment

The retrieval equipment, shown in Figure 1, includes a pallet on

which is mounted a winch, hoist, and operators controls; a safety fence which is mounted to the ramp door; a cable retrieving hook; and a snatch block pole.

The pallet is secured to the ramp floor by attachment to the standard cargo tie-down rings located in recesses in the floor. The winch consists of two cantilever suspended drums mounted to the winch gear box and is powered by an irreversible hydraulic motor. Manually-operated cable level-wind rollers are provided.

The hoist is used to stabilize the payload, swing it clear of the end of the ramp door, and hoist it on board the airplane.

The ramp door safety fence includes two inward opening gates to allow clearance for swinging the retrieved load aboard. The ramp door can be closed with the safety fence in place. The cable retrieving hook and snatch block pole are used by the operators to pickup the retrieving line and haul it in to attach to the winch.

Kit Suitability and Airplane Modification

The Skyhook Aerial Recovery System components, comprising the pickup equipment on the nose of the airplane and the retrieval equipment on the cargo ramp door, are designed as package units and may be stored as kits. The system can be installed quickly on aircraft subject to rescue missions after the following minor structure and system adaptations are accomplished:

1. Minor beef-up of the upper window sill longeron is required for adaption of the airplane nose pickup truss.
2. The hydraulic system pressure and return lines must be adapted for the pallet power source tie-in by installation of tubing tee fittings, quick-disconnect fittings, and dust caps.
3. The electrical system must be adapted for the Skyhook power source tie-in by the installation of an a-c quick disconnect plug-in type of junction box.
4. An intercommunication system control panel must be added in the cargo compartment near the pallet operator's station.

No other airplane modifications are required, and it is estimated that the system can be installed on a modified airplane in about two hours.

Electronic Equipment

All C-130A and C-130B aircraft are equipped with similar systems for communications, navigation, intercommunications among crew members, and announcements to personnel in or near the aircraft. Major components are located in the forward cargo compartment under the flight station. The pallet operator can communicate with the crew via the added control panel.

The search radar system, AN/APN-59 or AN/APS-42A, is capable of detecting a 10.8-foot-diameter aluminized retrieving cable balloon at as much as 33 nautical miles range. This unit can be used for

additional aid in locating the retrieving line balloon at night or in low visibility conditions.

Personnel Provision and Equipment Storage

The forward part of the airplane cargo compartment can be arranged to contain extensive provisions for the crew and survivors as shown in Figure 1. Provisions can be included for 26 litter patients, a galley, additional emergency oxygen, and seats for medical personnel and retrieval equipment operators.

Stowage of 26 individual personnel survival and aerial retrieving kits and a rack for the stowage of 25 spare winch drums can be provided in the aft part of the cargo compartment.

Weights

The weight distribution of the installed system including fixed, movable, and removable equipment such as survival kits, is such that the over-all CG travel is well within the allowable CG envelope of both the C-130A and C-130B airplanes.

Airplane Performance

The variation of time-on-station with mission radius for maximum fuel is shown in Figure 2. Time-on-station is computed at 125 knots equivalent air speed at sea level with the cargo ramp door open. The allotted time for each pickup is 15 minutes. Normally, airplane equipped

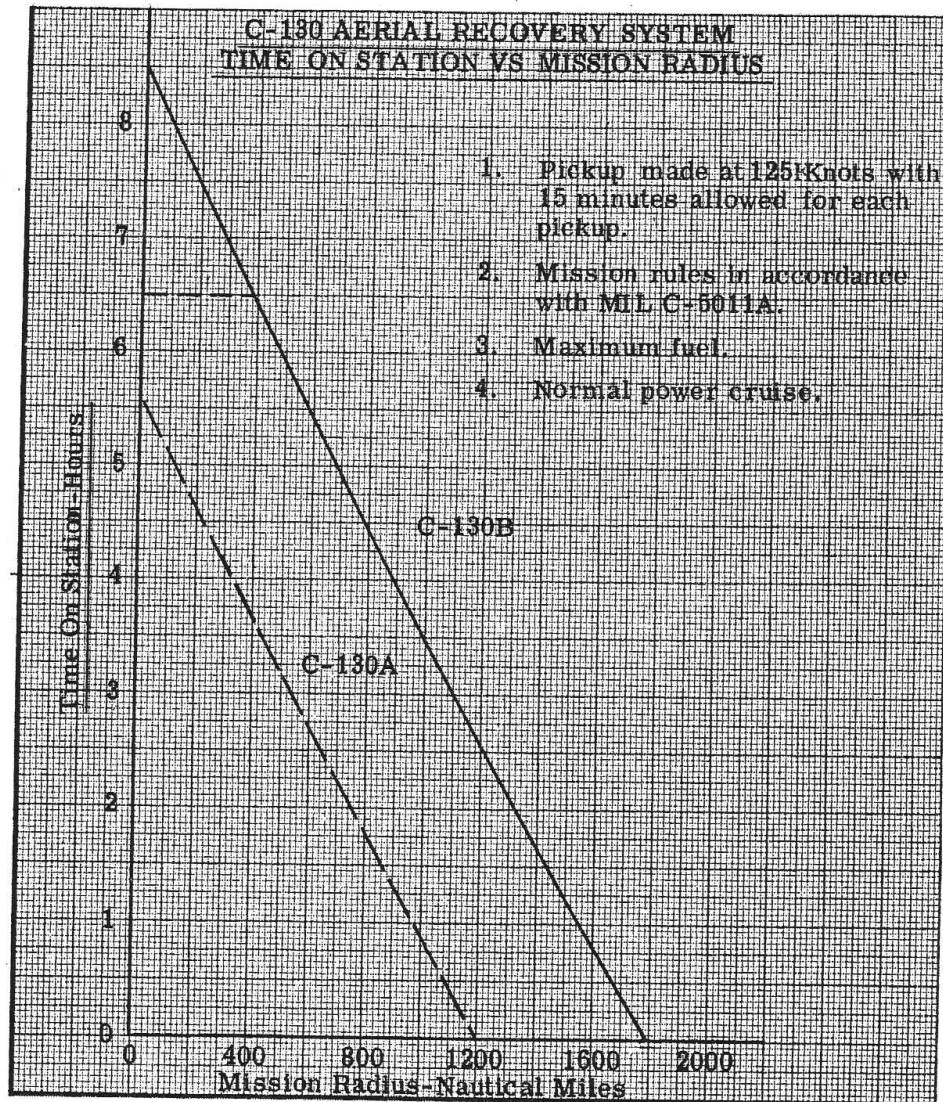

weight empty will vary with time-on-station inasmuch as the number of aerial pickups planned, which determine the required time-on-station, also determines the amount of equipment carried in the airplane.

The aerial pickup speed of 125 knots represents a comfortable margin over stall speed in both the clean and half-flaps configuration for the weight range anticipated for the majority of aerial recovery operations, for both the C-130A and C-130B.

Operational Sequence

Upon locating survivors, individual personnel survival and aerial retrieving kits are paradropped up wind of the survivors. The survival kits are retrieved by the survivors or by a recovery team which can be paradropped to assist in setting up the rigging for pickup.

In the case of personnel, the individual dons a survival suit which contains a harness attached to the retrieving line which is already attached to a balloon. A valve on a helium tank connected to the balloon is then opened to inflate the balloon which is then released.

After the pilot has made visual contact with the balloon following the required ground preparations he slows the airplane to 125 knots and maneuvers to a position down wind of the balloon. The aft airplane cargo doors are opened and the pallet operator positions the hoist. The pilot then approaches the balloon, flying into the wind at 125 knots, and flies directly into the retrieving line suspended under the balloon. When

contact is made, the yoke on the nose of the airplane guides the retrieving line into the Skyhook where attachment to the line is made automatically.

The pickup accomplished, the pilot maintains his attitude and heading for approximately 15 seconds to allow the load to stabilize. He then pulls the nose of the airplane up, to position the retrieving line along the bottom of the airplane.

The pallet operator then engages the line with the retrieving hook from the aft end of the ramp door and his assistant attaches the snatch block to the retrieving line. The winch is started and the snatch block line is wound in, to place the snatch block between the hoist roller and the winch drum. The winch is then stopped, and the pig tail is attached to the snatch block. The winch is then backed off, and the snatch block line is removed. A leader line from the large drum is pulled over the hoist roller and attached to the primary retrieving line. The winch is again started and operated until the retrieving line running forward to the Skyhook becomes taut. This line is then cut, and the free end is attached to a ramp door tie-down ring. The winch is then operated to draw the load in.

As the payload approaches the end of the hoist, the winch is slowed down. When the cable stop, as shown in Figure 3, makes contact with the hoist guide pulleys, the operator stops the winch and unlocks the hoist down lock. He then starts the winch again, and through the cable stop, the action of winding in the retrieving cable automatically raises

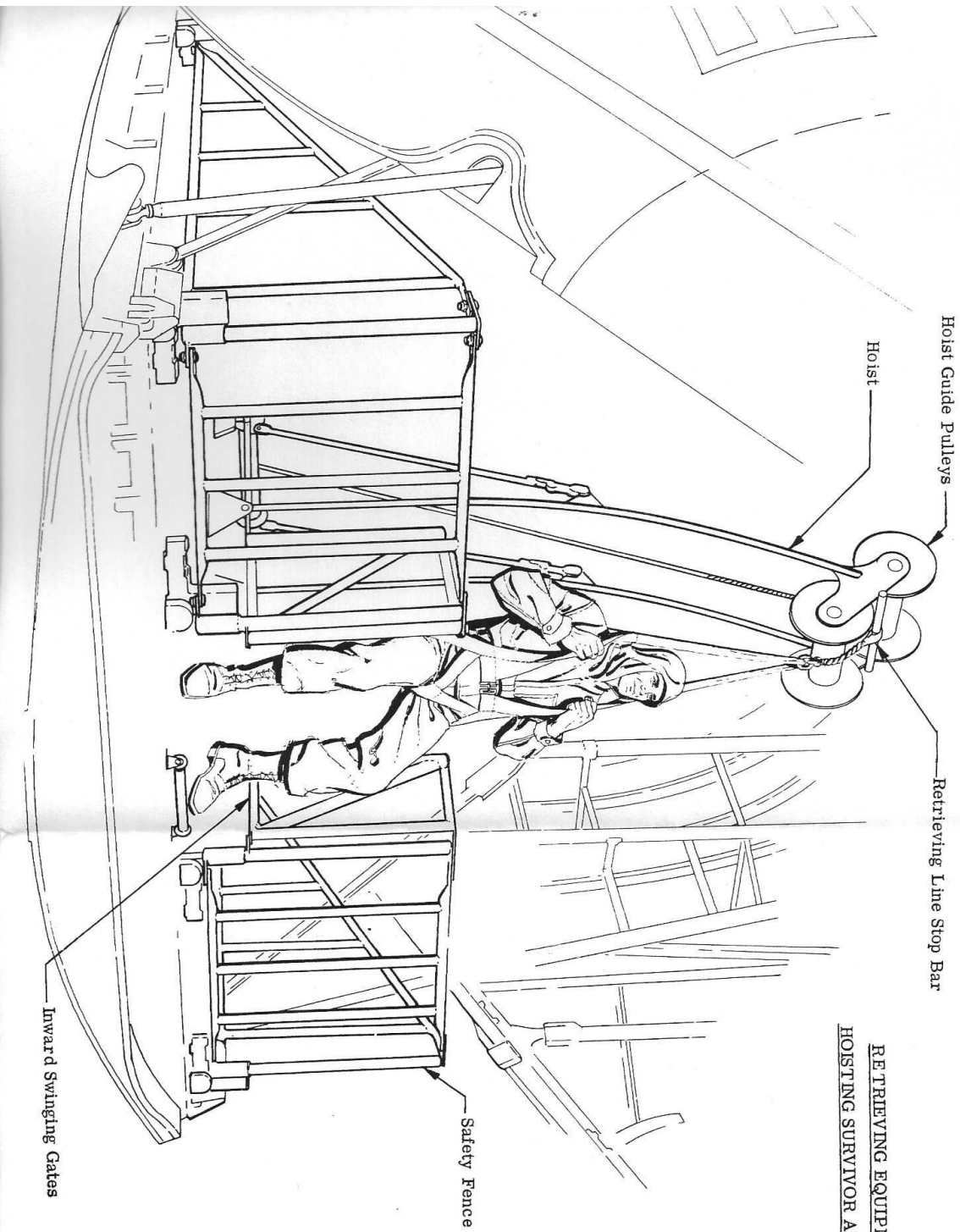

the hoist and hauls the payload aboard. When the hoist arm reaches the full-up position, the hoist arm engages the hoist up lock and automatically stops the winch. The operator then reverses the winch and lowers the load to the floor.

To re-rig the retrieval equipment a spare drum is installed in place of the full drum; the snatch block line is re-threaded over the hoist guide roller and through the guide pulleys on the end of the hoist; and the retrieval line is ejected from the Skyhook. The Skyhook is then "recocked" remotely by the pallet operator. The installation is now set for another pickup.

Pickup Capability

The system, which has been primarily developed to pickup one person at a time, has been designed structurally to pick up 600 pounds. This permits a multiple pickup of three 200-pound men or an equivalent load.

Pickups have been accomplished at night by attaching strobe lights to the balloon and retrieving rope. The lights may be controlled by the pilot or by ground personnel as desired. Tests have demonstrated that pickups can safely be accomplished from clear areas of less than 100 sq. ft., surrounded by obstructions as high as 100 feet, as well as from adverse terrain, such as mountains, forest, water, ice, and snow.

Protection and Safety

The effect of the induced acceleration forces on the human body due to the aerial pickup by this system has been carefully evaluated. The recorded accelerations, from numerous tests, have ranged from 4.5 g's to 10.2 g's with a mean value of 5.5 g's. Normal parachute accelerations range up to three times these values. Rate of onset of the pickup system accelerations are much lower than that of a parachute opening. As shown in Figure 4, the pickup recovery acceleration/time factors do not exceed human tolerance.

Adequate body protection for most operations is provided by the anti-exposure suit into which the pickup harness is sewn. For extremely cold weather, additional protection can be provided by a cape-like wind screen of rubberized nylon, which is draped around the survivor.

ACCELERATION PROFILE

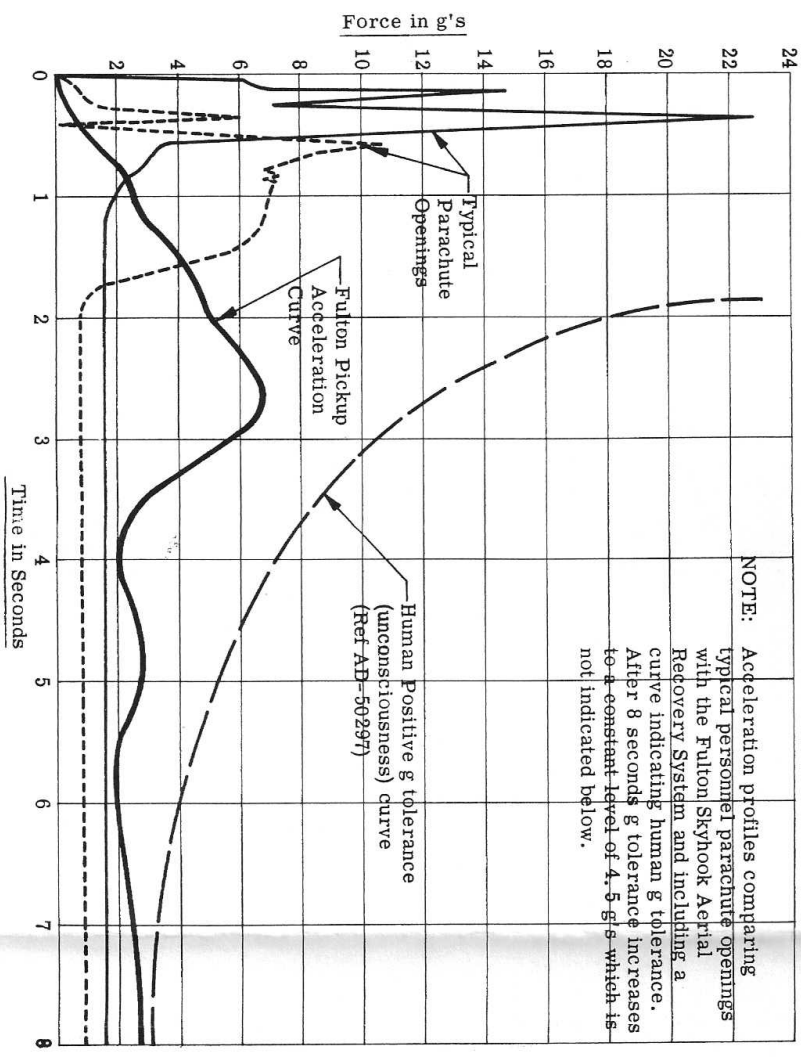

NOTE: Acceleration profiles comparing typical personnel parachute openings with the Fulton Skyhook Aerial Recovery System and including a curve indicating human g tolerance. After 8 seconds g tolerance increases to a constant level of 4.5 g's which is not indicated below.

II - INTRODUCTION

The Fulton Aerial Pickup System, commonly known as Skyhook or Aero-Retriever, was developed by Mr. Robert E. Fulton, Jr. of the Robert E. Fulton Company, Newtown, Connecticut for in-flight pickup of men and materials with high performance aircraft.

Originally this technique was proven by operational feasibility tests conducted under Office of Naval Research Contract NONR 1126 (00), in 1954 using a Lockheed P2V. Since that time, further extensive testing and evaluation of the equipment and concept was conducted at Quantico, Virginia from 1956 to 1958, by the Office of Naval Research in cooperation with the Marine Corps and the Robert E. Fulton Company.

The Lockheed C-130A and C-130B series aircraft including the "Ski 130" are particularly suited for the installation and application of the Fulton Skyhook Aerial Recovery System due to the airplane's high speed, long range, and due to its cargo hold and cargo door configuration, which is ideally suited for the recovery equipment and the recovery operation.

III - FULTON SKYHOOK SYSTEM

The Fulton Skyhook System provides a technique whereby a high-performance aircraft can recover in-flight men or materials from the earth's surface.

This is basically accomplished by attaching a long nylon line to the load to be recovered and suspending the line aloft with a balloon. As shown in Figure 5, the airplane then flies into the line, attaches itself to the line, and lifts the payload. The payload is then winched aboard the airplane.

Historical Note

The Skyhook system was first proposed to the Navy in 1954 to meet their growing need for a capability to pick up men and materials with long-range high-performance aircraft. While helicopters were capable of doing an excellent job, their range was so limited that the requirements for long-range rescue demanded another system.

The basic requirements called for a system which would:

1. Be capable of execution with an aircraft of the size and performance of a Lockheed P2V,
2. Not impose excessive acceleration forces on the load pickup,

FULTON SKYHOOK SYSTEM

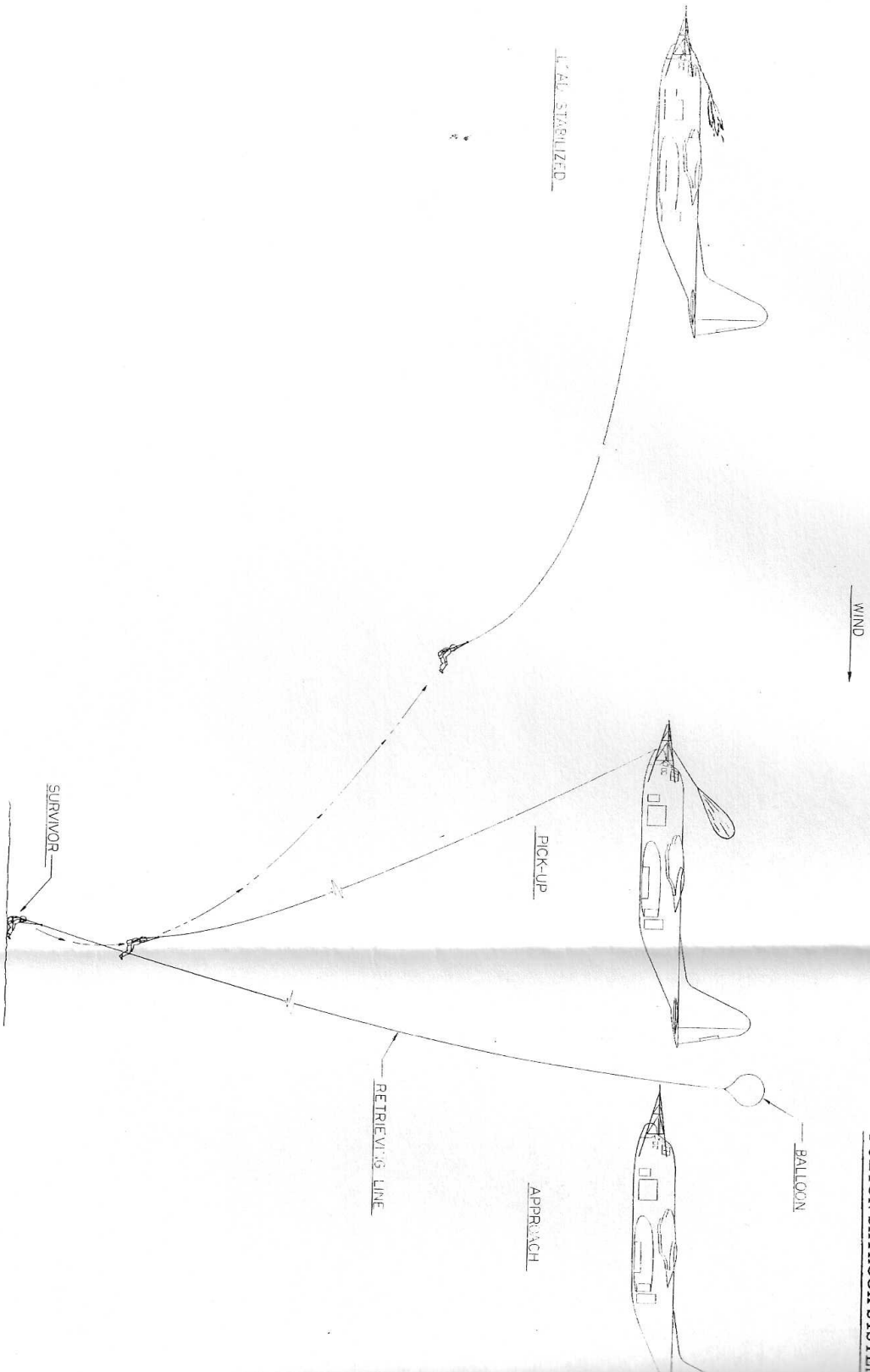

3. Permit the aircraft to operate at a safe altitude above the ground (not less than 300 feet),
4. Enable rescues to be performed out of small, highly obstructed areas,
5. Be capable of performance by night as well as by day, from the land or out of the water,
6. Not call for any special skill or lengthy training on the part of pilot and crew,
7. Work satisfactorily at a minimum speed of 125 knots,
8. Be simple in principle and operation,
9. Be capable of repetition so that more than one rescue could be accomplished during one mission, and
10. Permit quick installation on and removal from appropriate type aircraft so that the aircraft could remain available for their normal operational use, with rescue missions an added capability.

All these requirements are met by the Skyhook system. The following has been accomplished during extensive development and simulated operational testing:

1. Over 300 demonstration rescues have been successfully performed.
2. Loads up to 500 pounds have been picked up.

3. Multiple (more than one load at a time) as well as repeated single pickups have been performed.
4. Successful pickups have been performed at speeds up to 150 knots.
5. Six human pickups have been accomplished without injury.
6. Nineteen animal pickups have been made; some of the animals (pigs and monkeys) being picked up three, four, and five consecutive times.
7. Pickups by night have proven, essentially, as simple as by day.
8. It has been demonstrated that rescues can safely be accomplished from areas less than 100 square feet surrounded by obstructions as high as 100 feet. The pickup aircraft operates at a safe altitude of approximately 500 feet above the terrain.

Skyhook is an in-being rescue system, now ready for use on an operational scale. Further details on the operational testing of the Skyhook system may be secured from the Robert E. Fulton Company, Reference 1.

IV - SYSTEM APPLICATIONDesign Objectives

The following basic ground rules were established to guide the design for the application of the Fulton Skyhook Aerial Recovery System to the C-130A and C-130B airplanes:

1. Apply the proven Fulton Skyhook System to the C-130A and C-130B airplanes with minimum change,
2. Install with minimum aircraft modification,
3. Design equipment for kit packaging and minimum aircraft installation time,
4. Design the system with capability for pickup of personnel and light cargo to a maximum of 600 pounds at one time,
5. Provide capability for repeated pickups on one mission,
6. Plan system operation to require a minimum of operating personnel and special training needs, and
7. Incorporate means to insure the safety of operating personnel and recovered personnel.

General Arrangement

As shown in Figure 1, the general arrangement of the Fulton Skyhook Aerial Recovery System as installed to the C-130 airplane consists of the following:

**INBOARD PROFILE C-130B FULLTON
SKYHOOK AERIAL RECOVERY SYST**

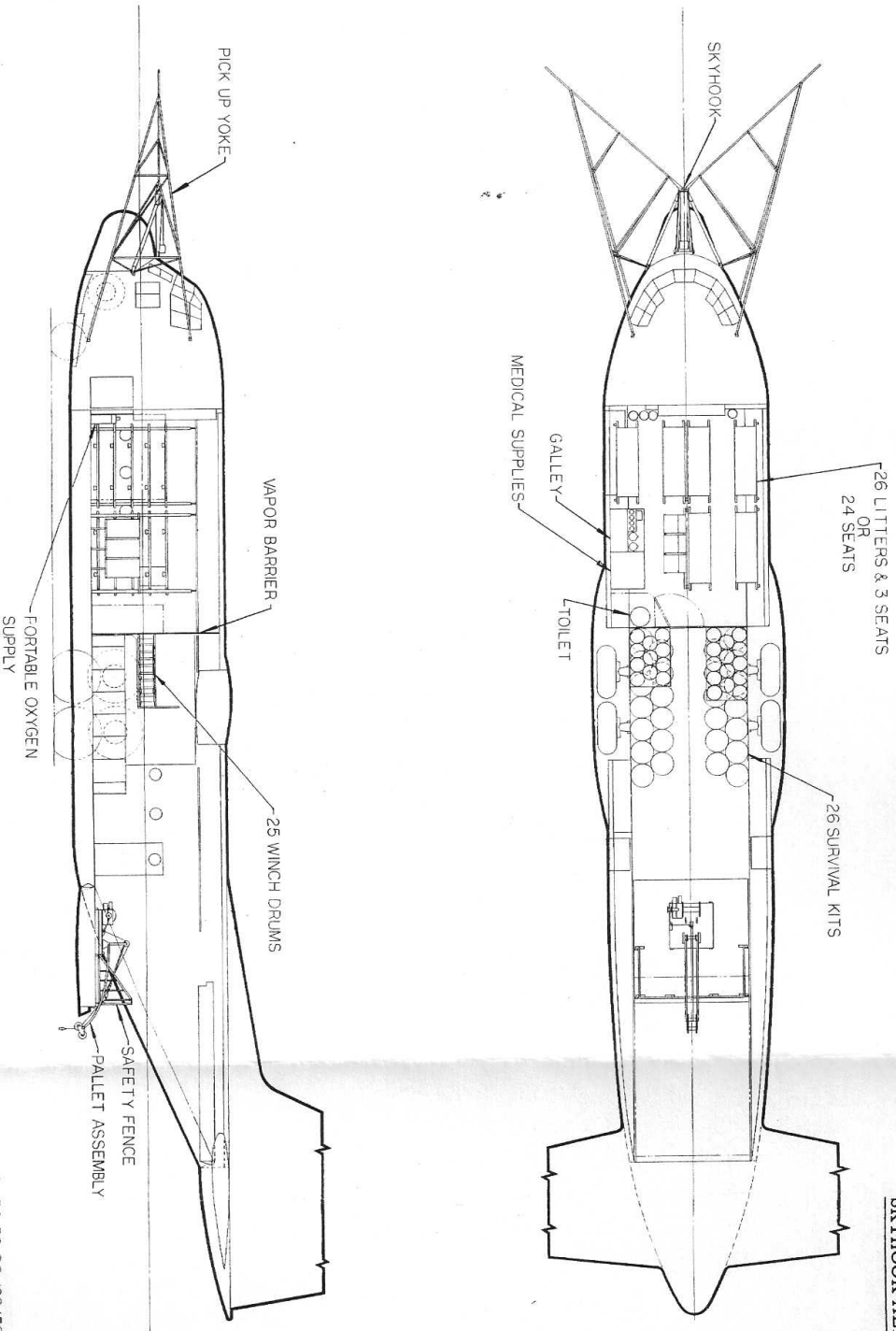

1. The pickup equipment located on the nose of the airplane which intercepts the nylon retrieving line suspended in the air with a balloon, and guides the retrieving line into the Skyhook, which attaches itself to the line and lifts the payload,
2. The retrieving equipment, located on the ramp door, which after attachment of the retrieving line to the winch by the operator, winds in the payload, and hoists it over the ramp door and on board the airplane, and
3. The personnel provisions and equipment storage racks in the cargo compartment of the airplane for the care of survivors and storage of survival kits.

The retrieving procedures required for the C-130 and those previously demonstrated on the P2V aircraft differ basically only in that the people being retrieved are taken in through a hatch in the lower aft fuselage in the P2V and through the open ramp door in the C-130.

In the case of the C-130, previous applicable flight test experience is available. Solid sheet metal drogues, similar to these used for refueling, attached to a cable have been trailed and retrieved through the C-130 open ramp door at various airspeeds and altitudes, and with various drogue sizes. The flow immediately aft of the ramp door is turbulent, which induced some drogue oscillatory motion while the drogue was located in this area. The addition of a 50-pound weight to the drogue, however, alleviated this difficulty completely. It is concluded from these results, that the retrieval of a person through the C-130 open ramp door

will pose no problems.

Pickup Equipment

The pickup equipment as installed on the nose of the C-130 is comparable to that tested and operationally proven on the Lockheed P2V. The pickup equipment, as shown in Figures 6 and 7, consists of the yoke, eye, Skyhook, yoke support truss, Skyhook support truss, retriever line deflector cable, and propeller guard cables.

The yoke has a spread of 24 feet, as shown in Figure 6, to provide ample tolerance for maneuvering the aircraft for a pickup. The yoke guides the retrieving line into the eye. The retrieving line triggers the Skyhook which secures the retrieving line and accomplishes the pickup. The yoke truss is bolted to the fuselage and is designed to be assembled in pieces. This is to allow ease of shipment and storage. The yoke and supporting truss are designed for the aerodynamic drag load plus a 1000-pound maximum tension load in the propeller guard cables. The yoke and vertical intercostal members of the truss are made of streamline tubing to reduce the aerodynamic drag. The longitudinal compression members of the truss are round tubing due to their angle relative to the airstream and are attached to the fuselage at two points, located on the upper window sill and lower longeron at fuselage station 165.0. Minor beef-up of the upper sill is required and attaching bolts must be pressure sealed. The propeller guard cables are attached to the forward end of the yoke support truss and to the airplane wing tip. Proper tensioning of the cables is accomplished by turnbuckles.

GENERAL ARRANGEMENT - FULL
SKYHOOK AERIAL RECOVERY SYS
C-139

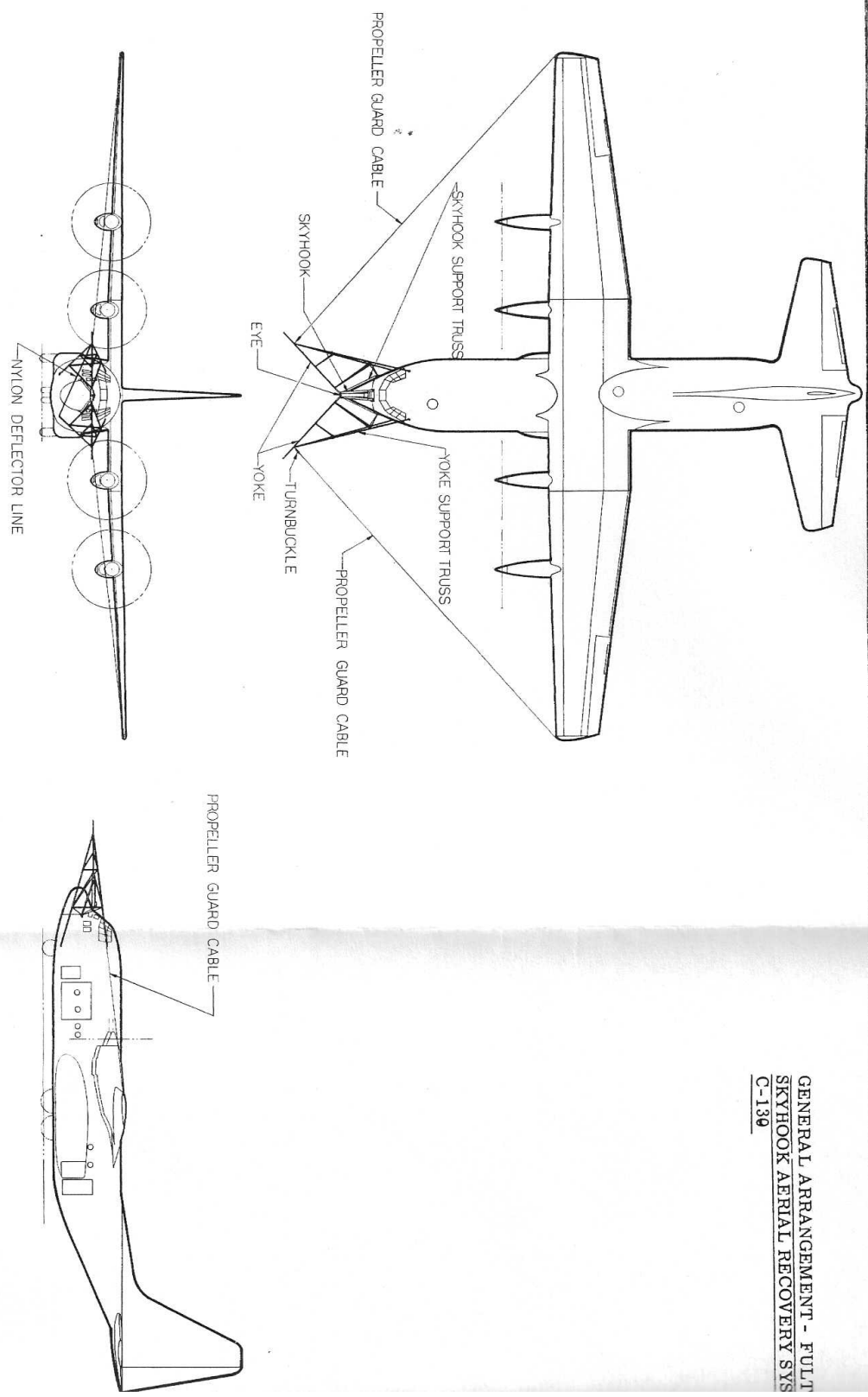

INSTALLATION - SKYHOOK A

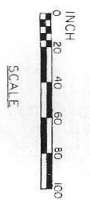
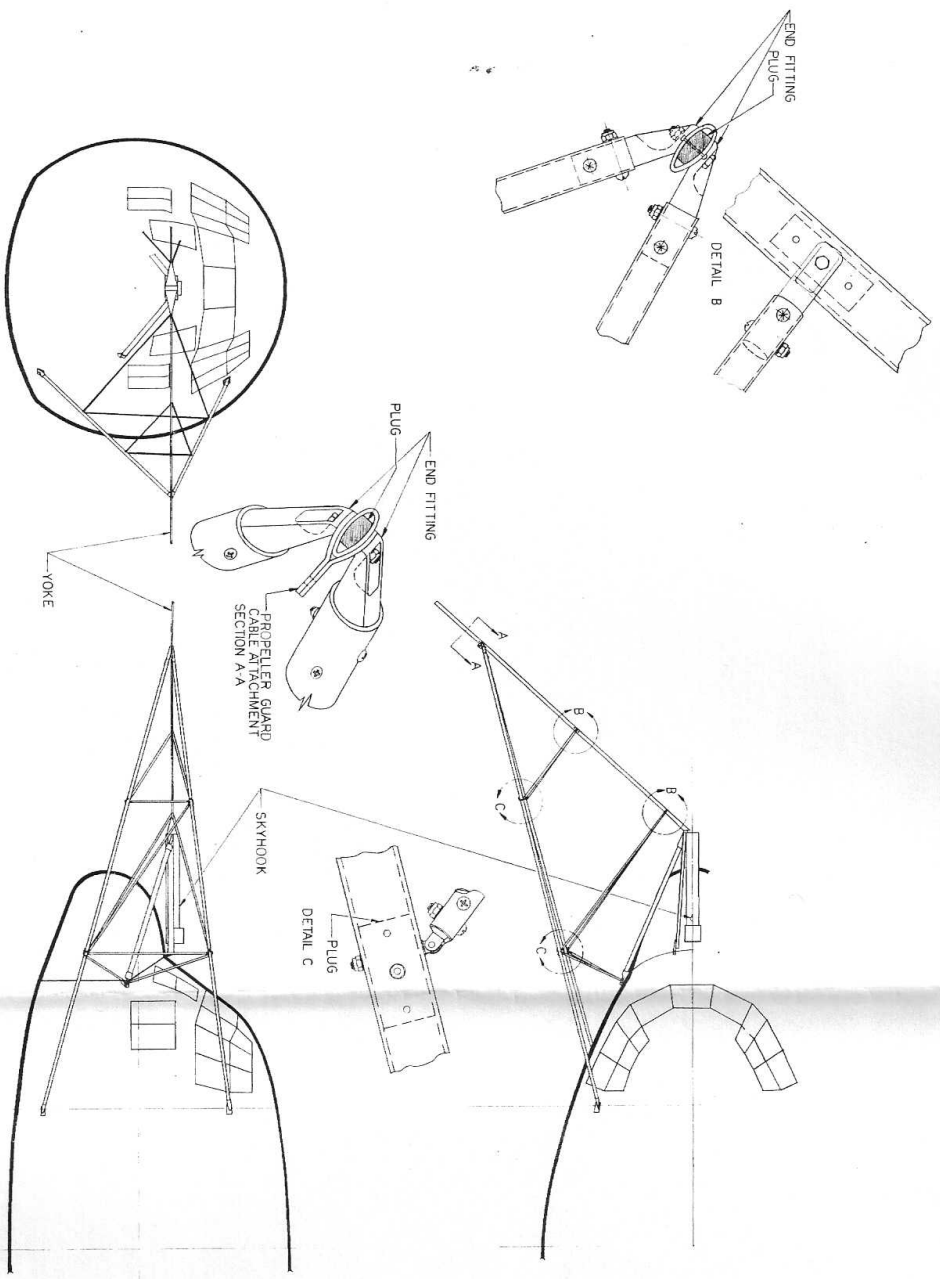

The Skyhook and its support truss actually carry the pickup load. The truss is attached to the nose of the airplane by bolts and fittings. The Skyhook and its supporting truss are designed to take a pickup load of 600 pounds at 15 g's, which is equivalent to a design ultimate load of 9000 pounds. The attachment fittings are supplied as kits to fit either the C-130A or C-130B airplanes. The truss supporting structure consists of four members attached to the fuselage. The upper two Skyhook platform tension members are attached to stiffeners between the bottom front windshield sill and the radome hinge brackets, by specially designed fittings. Dome nuts must be used with the attaching bolts and the assembly pressure sealed. On the C-130B, kit fittings use the hinge pins of the nose radome. The lower Skyhook compression members are attached to the outside contour of the fuselage at F.S. 93.0 and W.L. 195.0. Adequate strength is provided by the longeron to receive and redistribute load into the fuselage.

A nylon retrieving line deflector cable is attached to the forward right-hand side of the yoke and is stretched across in front of the radome and attached to the left-hand bottom yoke support truss compression member at the fuselage attachment fitting. The deflection cable prevents the pickup retrieving line from hanging up on the nose of the radome after it is secured to the Skyhook. If the deflector cable should fail, the Skyhook pickup structure is designed to allow the retrieving line to wrap directly around the nose of the radome, causing a local radome failure, but retaining the recovered load.

The Skyhook is remotely controlled by the retrieving pallet operator. The unit contains its own electric motor, gearing, and springs to perform its function of catching and holding the retrieving line. It is cocked, ready to receive the retrieving line, by the electric motor. It also has the ability to throw off the retrieving line in order to provide repetitive pickups.

The propeller-guard cable installation, as shown in Figures 6 and 7, protects the retrieving line from fouling the propellers in case the pilot misses the retrieving line with the yoke. As shown in Figure 7, the guard cable is attached to the forward end of the yoke support truss with a turnbuckle. This allows rigging the cable to the proper tension.

The wing tip attachment for the guard cable, as shown in Figure 8, is designed to prevent fouling of the retrieving cable as it slips around the end of the wing tip. No turnbuckle is provided on the wing-tip end of the guard cable. Internal wing-tip structure is adequate to take the cable tension load using the external strap around the running light. This strap distributes load around the wing tip and prevents high local stresses in the skin. The cable is aircraft quality, extra flexible stainless steel, covered with a nylon shroud. The shroud prevents fraying of the retrieving line should it slip along the guard cable. The shroud is not a separate sleeve, over the cable, but is molded to the cable to form a positive attachment.

As shown in Figure 9, the clearance provided between the guard wire and propeller on the P2V installation and that for the proposed C-130

INSTALLATION-GUARD CABLE-V

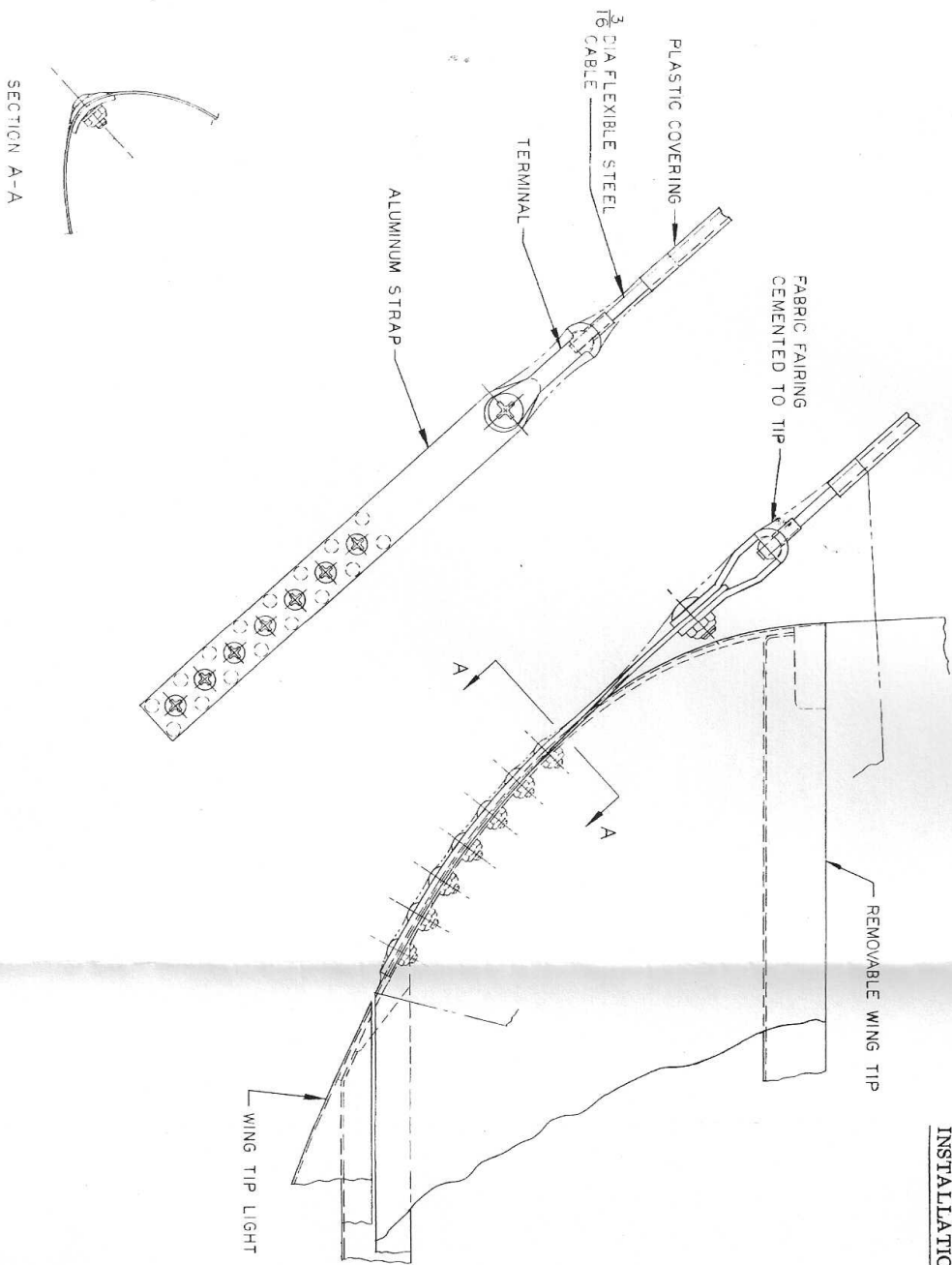

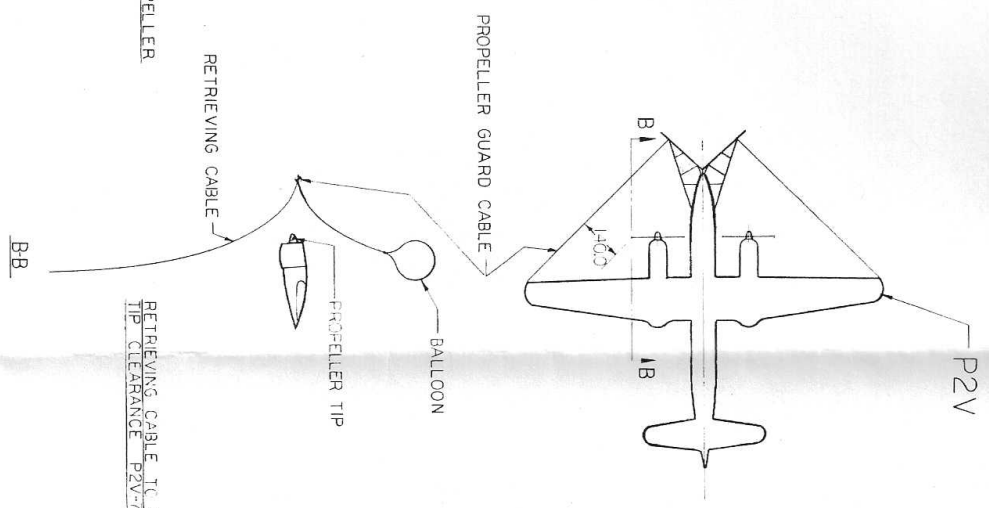
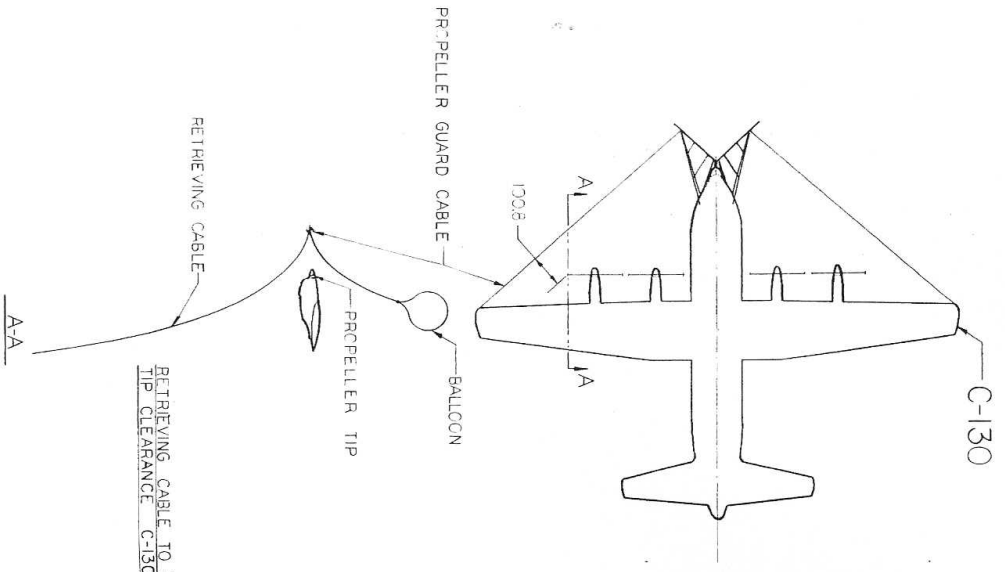

NO SCALE

installation is comparable. On the P2V, a static clearance of 140.00 inches was provided between the cable and the tip of the propeller. The rigging tension of the cable was approximately 200 pounds.

On the C-130 the static clearance between the cable and propeller tip is less than that on the P2V and amounts to 100.8 inches. The cable rig tension is also set at 200 pounds. It is felt that this clearance is adequate; however, the same clearance could be provided by extending the cable forward from the wing with a pole mounted on the wing leading edge.

Retrieval Equipment

The retrieval equipment for the C-130, as shown in Figure 1 and Figure 10, consists of the winch, hoist, and operator's controls mounted on a pallet. The pallet is designed as a self contained unit and is mounted on skids so that it may be moved by a fork-lift truck. This design avoids modification to the ramp floor and insures adequate distribution of the loads to the floor structure. The pallet is secured to the ramp floor by using standard fittings originally designed for the C-130 Aerial Delivery System. These fittings attach to the standard tie-down rings located in the recesses in the floor. Each ring is designed to hold a 5000-pound load and the pallet is secured to four rings.

The winch is designed to pick up a cargo with a gross weight not exceeding 600 pounds. The unit consists of two cantilever suspended drums mounted to the winch gear box. One drum, which is small, is

ASSEMBLY AND INSTALLATION-PALLI

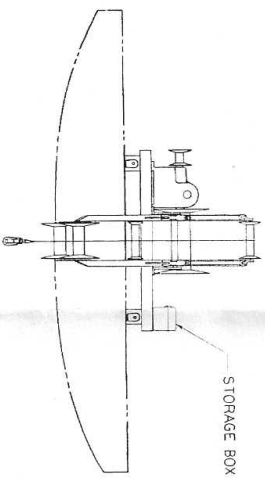
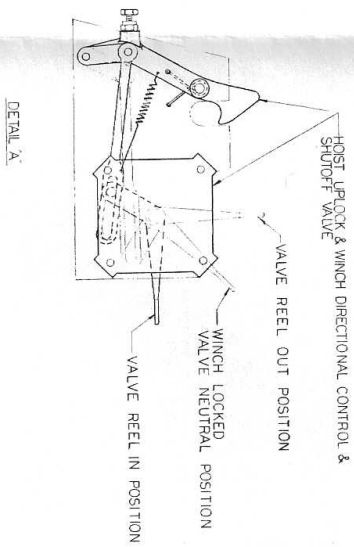
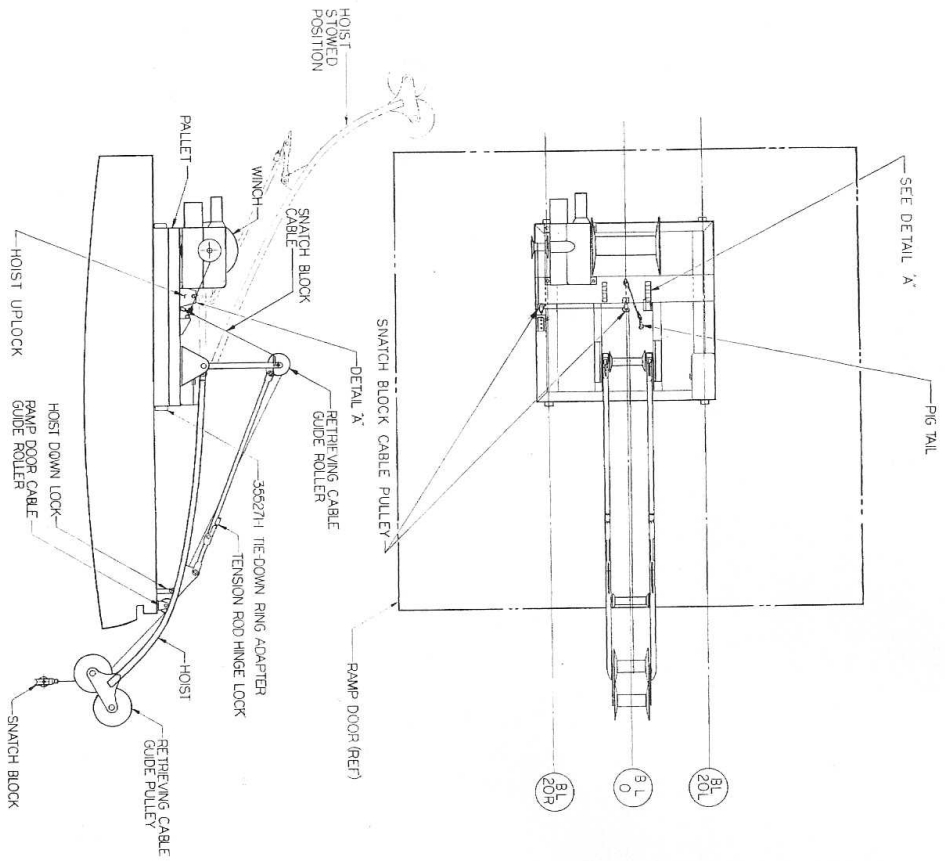

used in conjunction with a snatch block cable. The other drum, which is large, is used to wind in the primary retrieving line. The drums are powered, through a worm gear train, by an irreversible hydraulic motor. A pawl is provided for a positive fail-safe lock when the drums are stationary, and ratchets when the drums are winding in the cable. If the drums are powered in reverse, the pawl is raised. Cable level-wind rollers, provided for the large drum, are manually controlled. The large drum contains a nylon leader line, the free end of which has a cable clamp for attachment to the primary nylon retrieving line.

The hoist is used to stabilize the load as it is being retracted into the airplane and to swing the load clear of the end of the ramp door. The hoist is an unpowered boom actuated by a stop on the retrieving cable at the payload. This stop will not pass the hoist guide pulleys so continued cable retraction raises the hoist.

The operator's control panel contains the switches and valves necessary for the control of the winch and to reset the Skyhook on the nose of the airplane.

A safety fence, as shown in Figure 11, is provided around the edge of the ramp door. The ramp door can be opened or closed with the fence installed. Two inward opening gates are provided for swinging the retrieved personnel or cargo aboard. For safety, the gates cannot swing outward. The fence is installed by standard C-130 Aerial Delivery System pallet fittings that attach to the ramp door tie-down rings.

ASSEMBLY AND INSTALLATION - S
FENCE

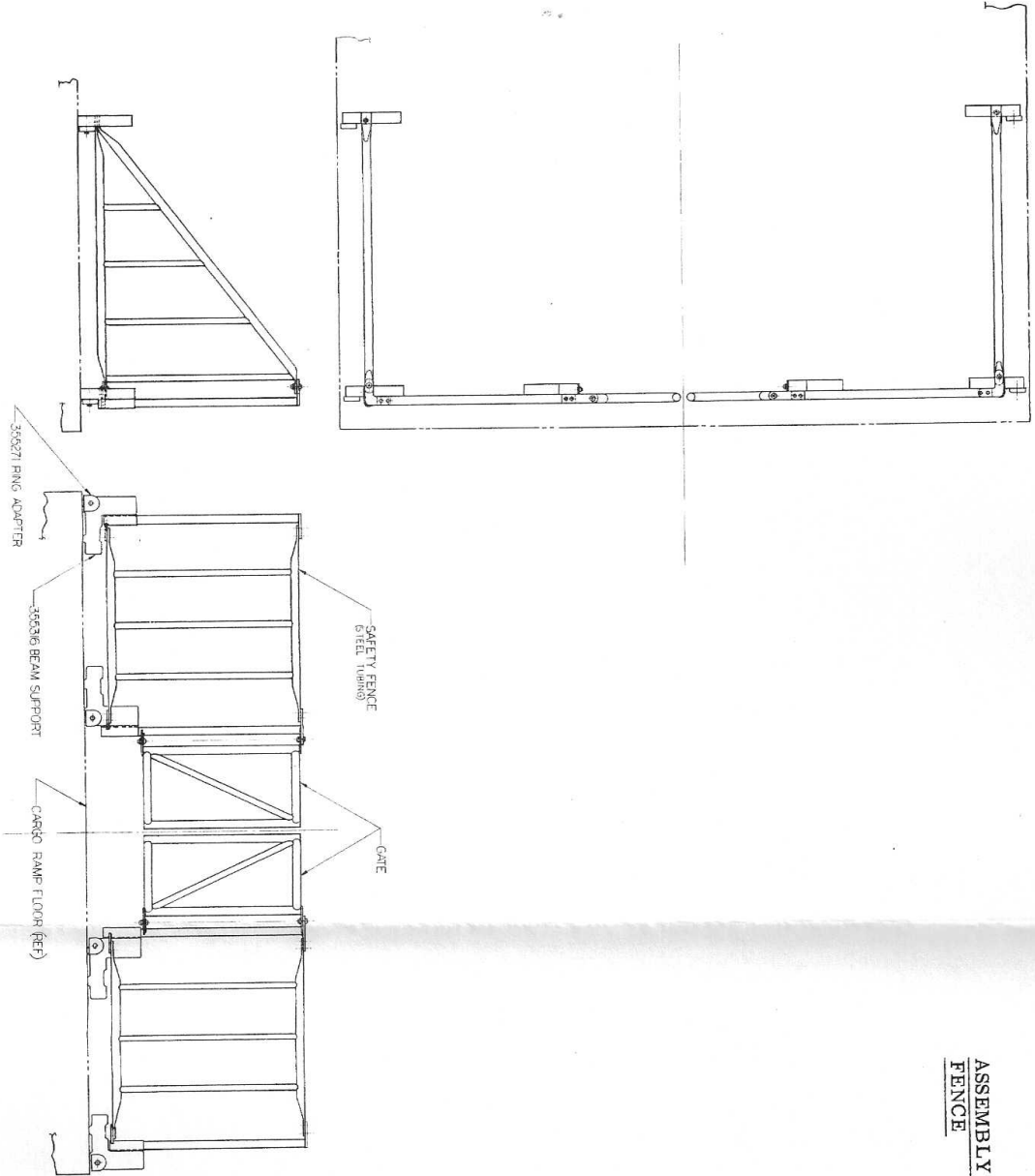

The pallet operator and his assistant are provided with a cable retrieving hook and pole and a snatch block pole, as shown in Figure 12. The snatch block pole can be quickly removed from the snatch block after attachment to the retrieving line.

Hydraulics - The hydraulic power for the winch is obtained from the aft ramp and brake emergency system, as shown in Figures 13 and 14. This system is a variable volume type with 8 gpm maximum flow and 3000 psi maximum pressure at flow cut off. On the C-130A the air turbine motor drives the hydraulic pump, and on the C-130B a 400-cycle 120-volt a-c motor drives the pump. The tie-in locations differ on the two models of the aircraft; however, both are in the area adjacent to the aft ramp and cargo door control panel. Connections are made to a pressure and to a return line both of which are reworked to include tubing tees, quick-disconnect fittings, and dust caps. The mating disconnect fitting is mounted on the proper pallet flexible hose connections. The disconnects are 1/2-inch tubing for the pressure and 3/4-inch tubing for the return to insure proper line connections. This dissimilar size is incorporated on the opposite hose end also.

The pallet hydraulic system is a simple closed center type. It consists of a flow control valve in the pressure line for the operator to control the reel speed. A three-position four-way, non-interflow, manually-operated directional control valve is used to select reel-in or reel-out. The valve cylinder ports are blocked in neutral to lock the reel when this position is selected. For reel-in, the operator selects the retract position, and controls the speed of operation. At the end of

PALLET OPERATORS - RETRIEVE
EQUIPMENT

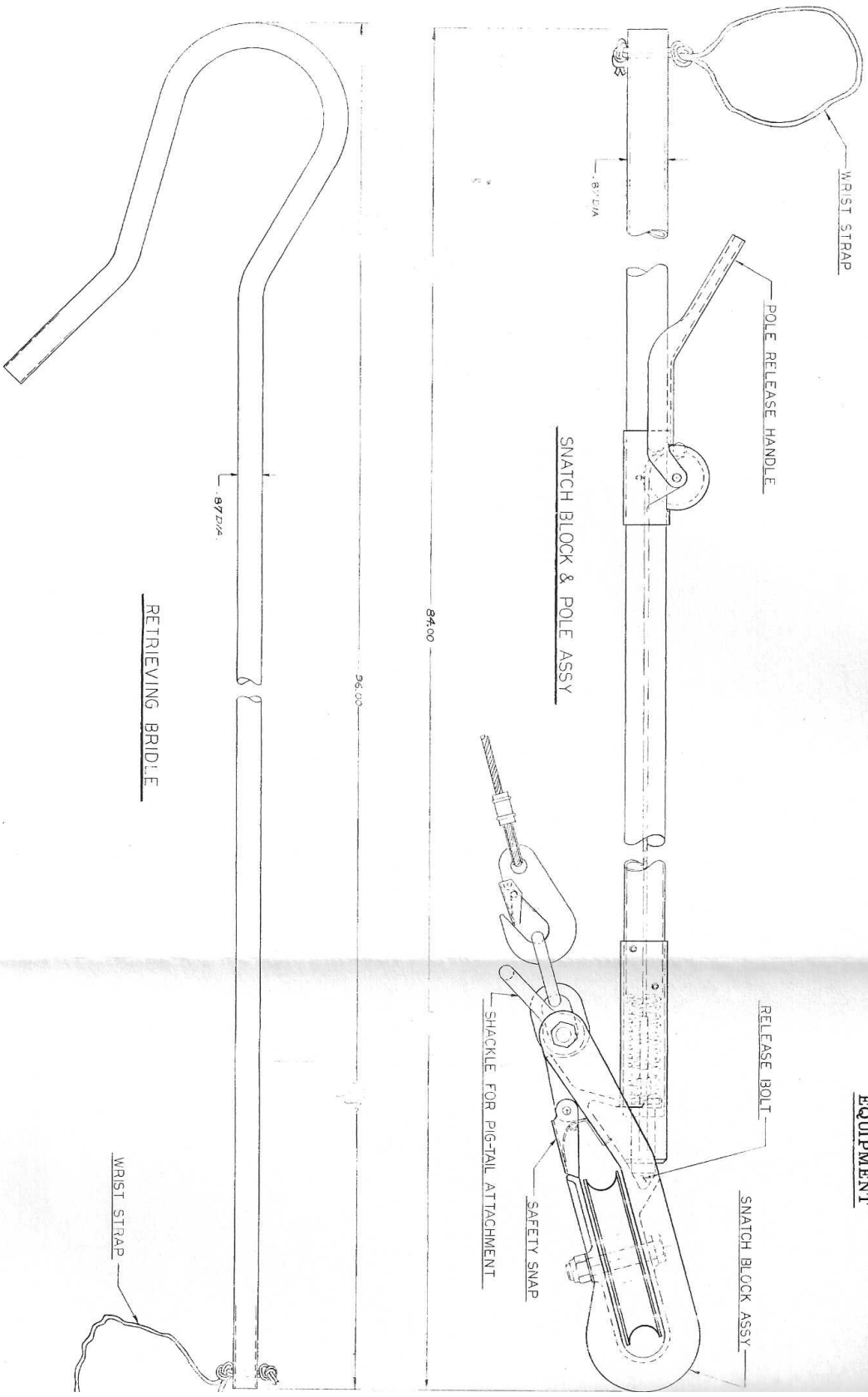

HYDRAULIC SCHEMATIC

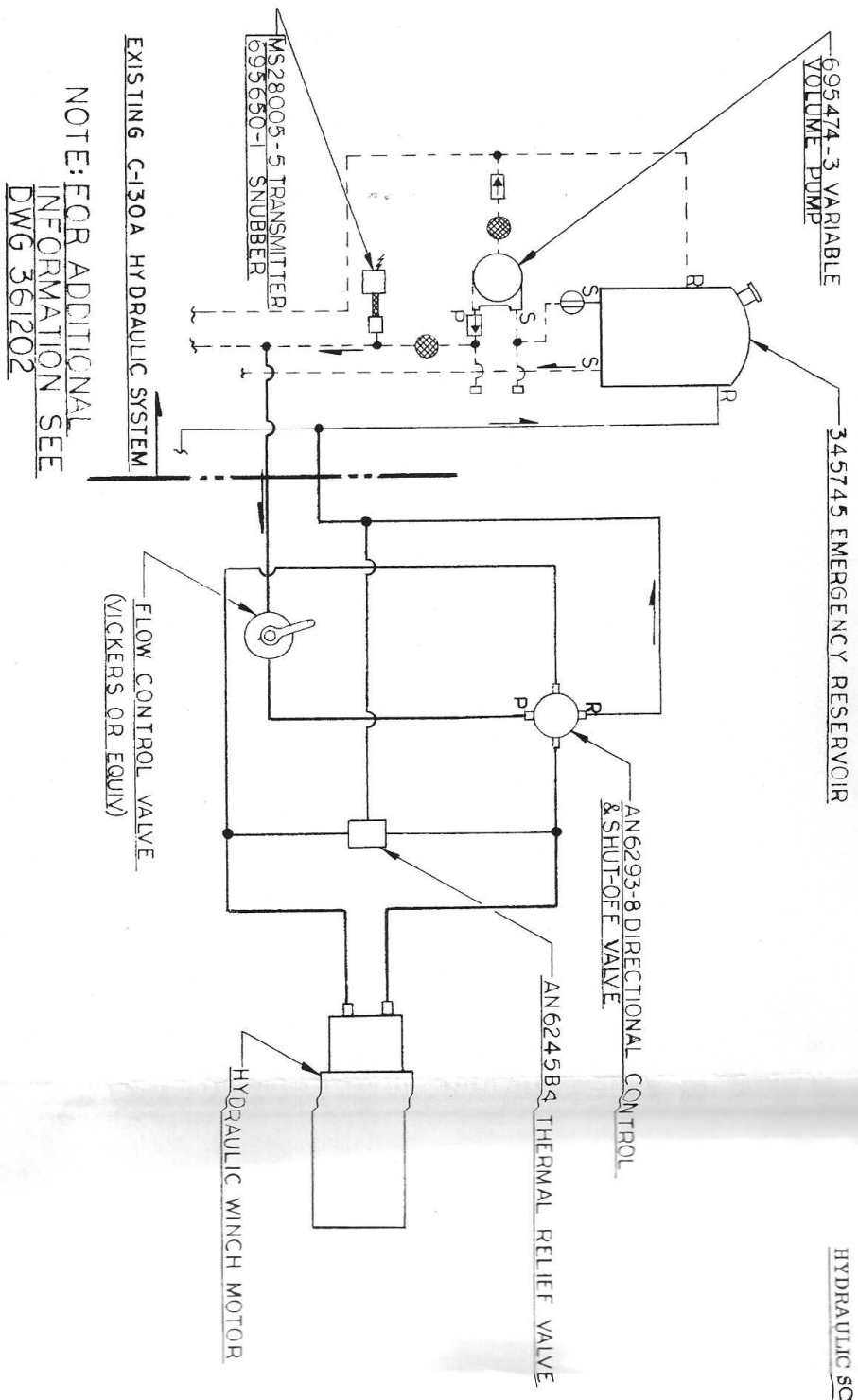

PALLET OPERATORS WINCH
HYDRAULIC SCHEMATIC
C130 A

HYDRAULIC SCHEMATIC - C-130B

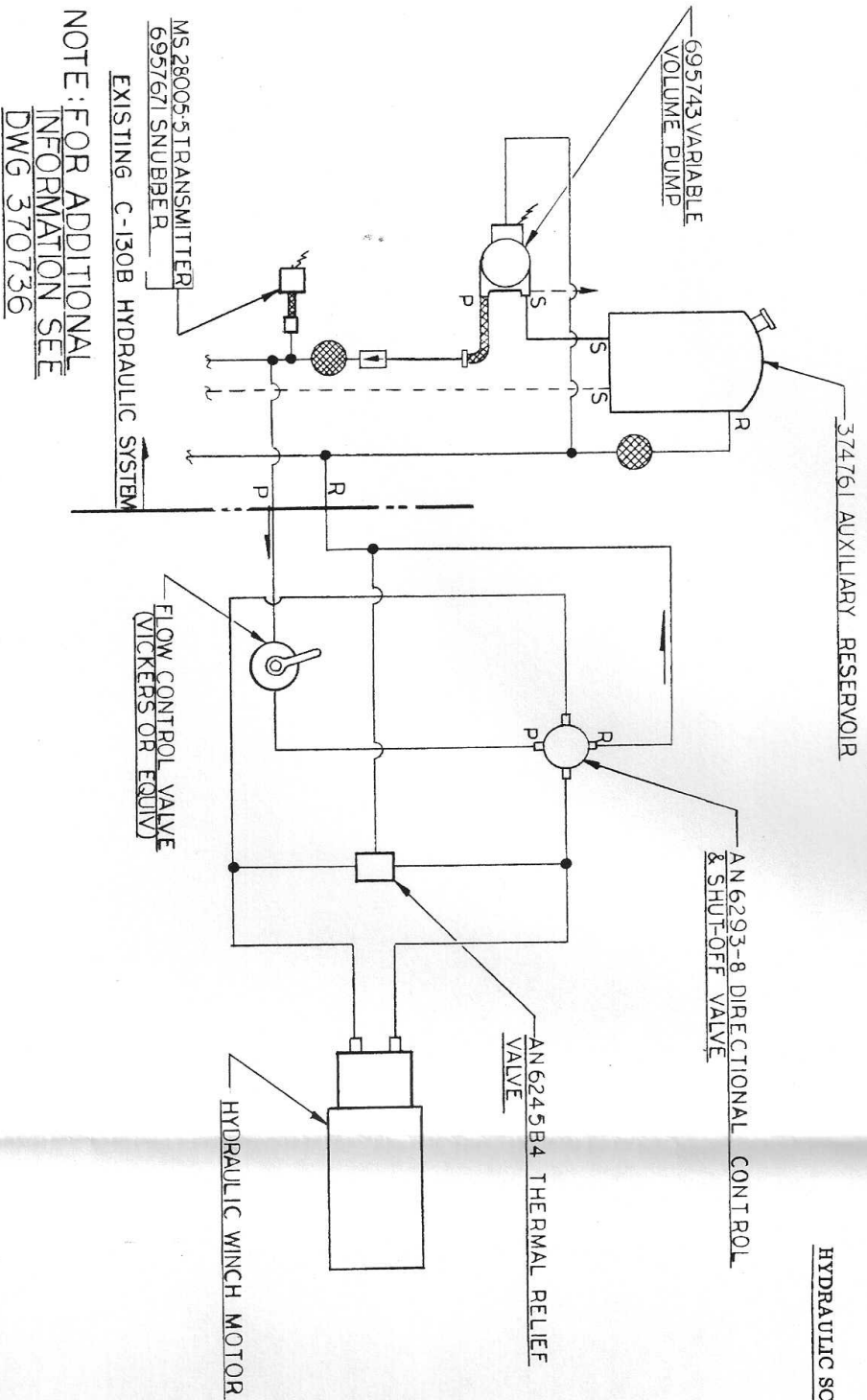

PALLET OPERATORS WINCH
HYDRAULIC SCHEMATIC
C130B

the cycle when the hoist is raised, an automatic trip mechanism returns the valve to neutral or locked position. The operator can then reverse the valve to lower the load onto the floor of the aircraft.

A hydraulic motor is used at a 60:1 gear ratio to drive the winch. Two thermal relief valves are incorporated in the motor lines to protect against oil temperature expansion. The motor has a 0.803-cu.-in.-per-revolution displacement. Neglecting efficiency, with the maximum system flow of 8 gpm at 2200 psi pressure, the torque is as shown in Figure 15. Also shown is the torque at cut-out flow and 3000 psi pressure. The minimum torque requirement for the winch is shown with the hoist extended when picking up the load. The maximum torque shown is a holding requirement with the cable and hoist retracted to the stops. Considering the maximum flow, the 60:1 drive ratio, and minimum winch cable diameter, the maximum cable speed with the cable fully extended could be 45 1/2 feet per minute and with the cable fully retracted, could be 132 feet per minute. With the flow control valve and variable volume pump, these speeds are controllable to zero velocity.

Kit Suitability

The Skyhook Aerial Recovery System components are designed as package units that can be stored as kits.

The pallet is a self contained unit designed to include all items of equipment pertaining to its operation. It has a box for storage of tie-down fittings, bolts, and tools. The pallet is mounted on skids for ease of movement with a fork-lift truck.

OPERATING TORQUE
INPUT REQUIRED
VS
OUTPUT AVAILABLE

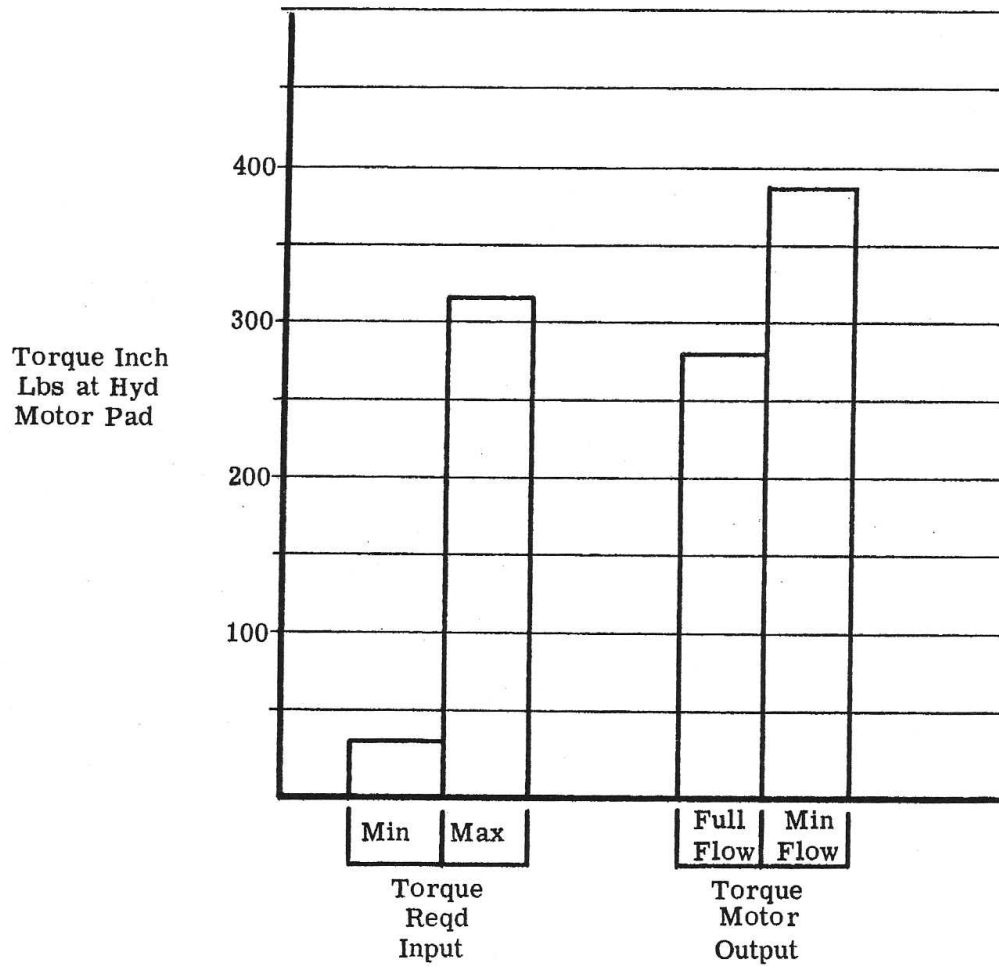

Items such as the galley, survival kits, medical supplies, litters, seats, and safety fencing are designed for quick installation. These items are also stored as kits.

The pickup equipment for the nose of the airplane is designed to be quickly assembled or disassembled and stored as a package of individual parts. Fittings for attachment of the pickup equipment to the fuselage are supplied in the kits to fit either the C-130A or C-130B airplanes.

The minor modifications required for an aircraft to accept this installation have been described and are summarized as follows:

1. Minor beef-up of the upper window-sill longeron is required for adaption of the airplane nose pickup truss.
2. The hydraulic system pressure and return lines must be adapted for the pallet power source tie-in by installation of tubing tee fittings, quick-disconnect fittings, and dust caps.
3. The electrical system must be adapted for the Skyhook power source tie-in by installation of an a-c quick-disconnect plug-in type of junction box.
4. An intercommunication system control panel must be added in the cargo compartment near the pallet operator's station.

Once the structure and system adaptations are made and the quick-disconnect-type fittings are installed on an aircraft subject to rescue missions, all the equipment in the kits such as the pallet assembly,

safety fence, and Skyhook pickup equipment items can be quickly installed. The airplane nose installation, consisting of the Skyhook and supporting truss, yoke and supporting truss and propeller guard cable installation, and retrieving line deflector cable, is designed to be bolted together, then bolted to the airplane. It is estimated that this complete installation should take no more than two hours. During this time period the pallet assembly is installed to the aft cargo ramp door by attaching it to the standard cargo tie-down fittings with the special fittings designed for this purpose. The pallet hydraulic connections are accomplished by flex high-pressure hose supplied with quick-disconnect fittings. The safety fence is also attached to the ramp door with fittings designed to fit the standard ramp-door tie-down rings.

Electronics Equipment (C-130A and C-130B)

Similar electronic systems are provided in both the C-130A and C-130B for communication, navigation, intercommunication among crew members, and announcements to personnel in or near the aircraft. Remote control panels for the various systems are located on the flight control pedestal and on the navigator's control panel. Major components of the systems are located in five equipment racks below the navigator's work table and forward of the cargo compartment under the flight station floor. Antennas are mounted above and below the fuselage and in the nose radome to give the best possible radiation patterns consistent with the space and radio interference limitations.

An AN/ARC-34 UHF communication system provides communication from 225.0 mc to 399.9 mc, and a guard channel receiver operating from

238.0 through 248.0 mc. A flush antenna on the bottom fuselage and an additional stub antenna on the C-130B top fuselage are used for the AN/ARC-34.

Communication in the frequency range of 100 to 156 mc is provided by an AN/ARC-49 VHF communication system. A mast antenna mounted on the bottom fuselage, just forward of the main landing gear, produces an omni-directional radiation pattern.

Two Collins 618S-1 liaison communication systems allow voice reception and transmission on any of 144 channels in the frequency range of 2 to 25 mc. An external wire antenna is installed between the vertical stabilizer and a mast on the forward upper fuselage for each transceiver. An AN/ARA-26 emergency keyer system provides a mechanical keying device which will automatically turn on, tune, and key the No. 1 HF liaison transceiver to transmit a coded distress signal over the international distress frequency of 8364 kc.

Either an AN/CRT-3 or AN/CRT-3A emergency transmitter is installed in a compartment in the left center-wing section. This set is for emergency operation outside the aircraft and transmits an SOS distress signal on either 8280 kc or 8364 kc and 500 kc when the built-in hand-powered generator is cranked by the operator.

The AN/AIC-10 or AN AIC-10A intercommunication system provides communication between each of the crew members and permits each to monitor all radio communication and navigation receivers. Provisions

are made for the pilot, copilot, and navigator to transmit over the communication system through the intercommunication system. Intercommunication with the crew is provided the pallet operator by installation of a control panel at his station. One way communication with the cargo area and aircraft exterior is provided by an AN/AIC-13 public address system on the C-130B, and a system using Bendix amplifiers and Racon speakers in the C-130A. Input to these PA systems is through the intercommunication system.

Omni-range, localizer, and voice reception in the frequency range of 108.0 through 135.9 mc is provided by the AN/ARN-14 VHF navigation receiver. The receiver utilizes an antenna in the vertical stabilizer.

Vertical guidance, during instrument landings, using the AN/ARN-14 localizer, is provided by the AN/ARN-31 glide path receiver, or the AN/ARN-18 glide path receiver on some C-130A aircraft. This receiver automatically tunes to the proper glide path frequency between 329.3 and 335.0 mc when a localizer frequency is selected on the AN/ARN-14. The antenna is mounted in the radome, either above or below the radar antenna.

An AN/ARN-21 tacan system provides omni-bearing and range information to any selected tacan ground surface beacon located within a line-of-sight distance up to 195 miles. A flush antenna on the bottom fuselage of the aircraft and an additional stub antenna on the top fuselage of the C-130B is used for the AN/ARN-21.

To indicate the relative bearing of a UHF transmitting station, the AN/ARA-25 UHF direction finder system replaces the normal AN/ARC-34 antenna. The AN/ARA-25 utilizes a rotating directional antenna mounted below the cargo compartment floor behind a fiberglass window in the fuselage skin.

A remote-indicating, gyro-stabilized, magnetic-slaved N-1 compass system is installed. It can be operated either as a directional gyro, manually corrected for local latitude, or as a magnetic-slaved compass. The direction-sensing remote compass transmitter is located in the left wing tip.

The MA-1 flight director system receives information from the N-1 compass, AN/ARN-31 glide path receiver, AN/ARN-14 VHF navigation receiver, and AN/ARN-21 tacan. The system provides the information needed to make ILS approaches, fly VOR or VAR courses, fly compass headings, and maintain proper pitch and roll attitudes.

Long-range navigation is provided by the AN/APN-70 loran system which detects loran station signals in the frequency ranges of 90 to 110 kc, 170 to 190 kc, and 1700 to 2000 kc. The receiver is connected to the No. 2 liaison communication system antenna through an antenna coupler.

Two AN/ARN-6 radio compass systems are installed to provide direction-finding information in the frequency range of 100 through 1750 kc. Each system has a directional loop antenna and a non-directional sense antenna installed below the cargo compartment floor aft of the main landing gear.

Either an AN/ARN-32 or AN/ARN-12 marker beacon receiver is installed, with a flush antenna in the bottom fuselage, to inform the crew of passage over a 75 mc marker beacon transmitter.

The AN/APN-22 low-range radar altimeter and the SCR-718 high-range radar altimeter are installed to indicate the height of the aircraft above the ground surface.

The aircraft identifies itself as friendly with the AN/APX-25 IFF radar identification system. In some aircraft the coder unit is not included and the system is then known as AN/APX-6A and operates only in the Mark X mode.

The AN/APN-59 search radar system, or the AN/APS-42A in early C-130A aircraft, provides visual indication of the relative location of cities, landmarks, shorelines, islands, ships, other aircraft, cloud formations, and radar beacon stations. The system operates at 9375 mc and presents targets up to 240 nautical miles away. A 10.8-foot-diameter aluminized retrieving cable balloon can be detected up to 33 nautical miles. The radar has an unobstructed view below the aircraft through an azimuth angle of 136° . Masking by the nose truss results in a 7-percent loss of range at a 90° azimuth angle, and in the worst condition, -2° elevation and $\pm 105^{\circ}$ azimuth, a range reduction of only 10 percent results. Some beam deflection may result from the truss structure but is not great enough to be considered significant. The MK-59/AP, AN/ASQ-12, or AN/ASQ-14 radar pressurization system is used to maintain a sea-level atmospheric pressure in the receiver-transmitter and antenna wave guide.

The AN/APA-52A doppler drift system is provided with the search radar to furnish an accurate means of measuring airplane drift. The system provides a very accurate means of positioning the radar antenna along the aircraft ground track.

Adequate space, power, and cooling are available to accommodate any additional electronic equipment deemed necessary to accomplish any specific mission. Additional antennas may be installed flush in the aircraft skin, or, if necessary, radomes may be added. Engineering exists for a three-foot-diameter radome, extending approximately three feet below the nose radome. This is an excellent installation for most systems requiring 360° D/F coverage in azimuth, below the aircraft.

With all power generating equipment operating, electric power available for additional equipment is 25 kva a-c and 800 amps d-c on the C-130A, and 80 kva a-c and 400 amps d-c on the C-130B.

Personnel Provision and Equipment Storage

Excellent provisions for additional personnel and equipment storage can be installed in the C-130 cargo compartment; although they are not elements of the basic aerial recovery system.

The forward part of the airplane cargo compartment contains all the provisions for the crew and survivors, as shown in Figure 1. This area is separated from the aft cargo compartment by a vapor membrane so that litter patients will suffer no discomfort during air rescue operations.

Provisions for 26 litter patients can be included. There are three tiers of five litters each at the centerline of the airplane and two tiers of four litters each and one tier with three litters on the sides of the airplane. Seats can replace litters if desired.

The galley has provisions for 68 frozen meals; two meals each for the crew and survivors. In addition there are provisions for 10 hours of oxygen for two patients at 5000 feet altitude, medical supplies for 26 patients, and seats for one medic and two retrieval equipment operators.

The airplane crew consists of the following personnel:

Standard Crew - C-130

Pilot
Copilot
Flight Engineer
Radio Operator and Navigator

Additional Crew

Pallet Operator
One Medic Attendant
Pallet Operations Assistant

Stowage for 26 individual personnel survival and aerial retrieving kits and for storage of 25 spare winch drums is provided in the aft portion of the cargo compartment. This is based on single level stowage on the

cargo floor. The kits are stored in drums and contain the following:

- One air drop parachute,
- One 500-foot nylon retrieving rope and fittings,
- One balloon,
- Helium tanks for balloon inflation,
- One personnel retrieving harness and survival suit, and
- Medical kit.

The kits are air dropped from the paratrooper doors. The chutes are automatically opened in the same manner as paratrooper chutes by attaching the static line to an overhead door fitting or anchor line before pushing the load overboard.

A roller platform can be installed on the floor at the doors to aid in sliding the kits overboard.

The provisioning as described constitutes the maximum provisioning of the C-130 and is not necessarily compatible with the airplane mission profile capability. The 26 pickups which the facilities can accept would require six and one-half hours of continuous pickup operations if each pickup averaged only 15 minutes each.

Weight and Balance

This subsection contains weight summaries and balance diagrams for the basic C-130A and C-130B aircraft equipped with the Fulton Aerial Recovery System.

Derivation of Aircraft Weight - The weight and balance characteristics of the basic C-130A and C-130B are based on actual weight and balance of Lockheed's production aircraft. The weight and balance effects of all changes to the basic aircraft have been estimated from limited design layouts and equipment requirements available.

Weight - The weight summary shown in Figure 16 reflects the changes required for the installation of the recovery system to the basic aircraft. As outlined in the preceding paragraph, it is based on preliminary information and design layouts.

Balance - The center of gravity diagram, as shown in Figure 17, presents the resulting balance conditions for the C-130A aircraft equipped with the recovery system. Figure 18 shows the balance effects for the C-130B installation.

From these figures it can be seen that good balance characteristics exist, for both airplanes.

WEIGHT SUMMARY

	<u>C-130A</u> <u>Weight-Lbs.</u>	<u>C-130B</u> <u>Weight-Lbs.</u>
Revised Basic Weight *	61,986	69,389
Food and Water	357	302
Water Bottles	43	43
Toilet	48	48
Crew (3) - Additional	600	600
First Aid Kits (16)	35	35
Medical Supplies	154	154
Oxygen Bottles	128	128
Litters (26)	390	390
Survival Kits (26)	7,950	7,950
Roller Platforms (2)	27	27
Vapor Barrier and Door	15	15
Spare Drums (25)	125	125
Ramp Extension (2)	89	89
Pickup	160	160
Pallet and Equipment	452	452
Revised Equipped Weight Empty	72,559	79,907
Litter Patients (26)	5,200	5,200
Gross Weight (No Fuel)	77,759	85,107
Fuel (Full)	34,125	45,240
Take-Off Gross Weight (Full Fuel)	111,884	130,347

* Basic Weights from ER's 3121 and 3622.

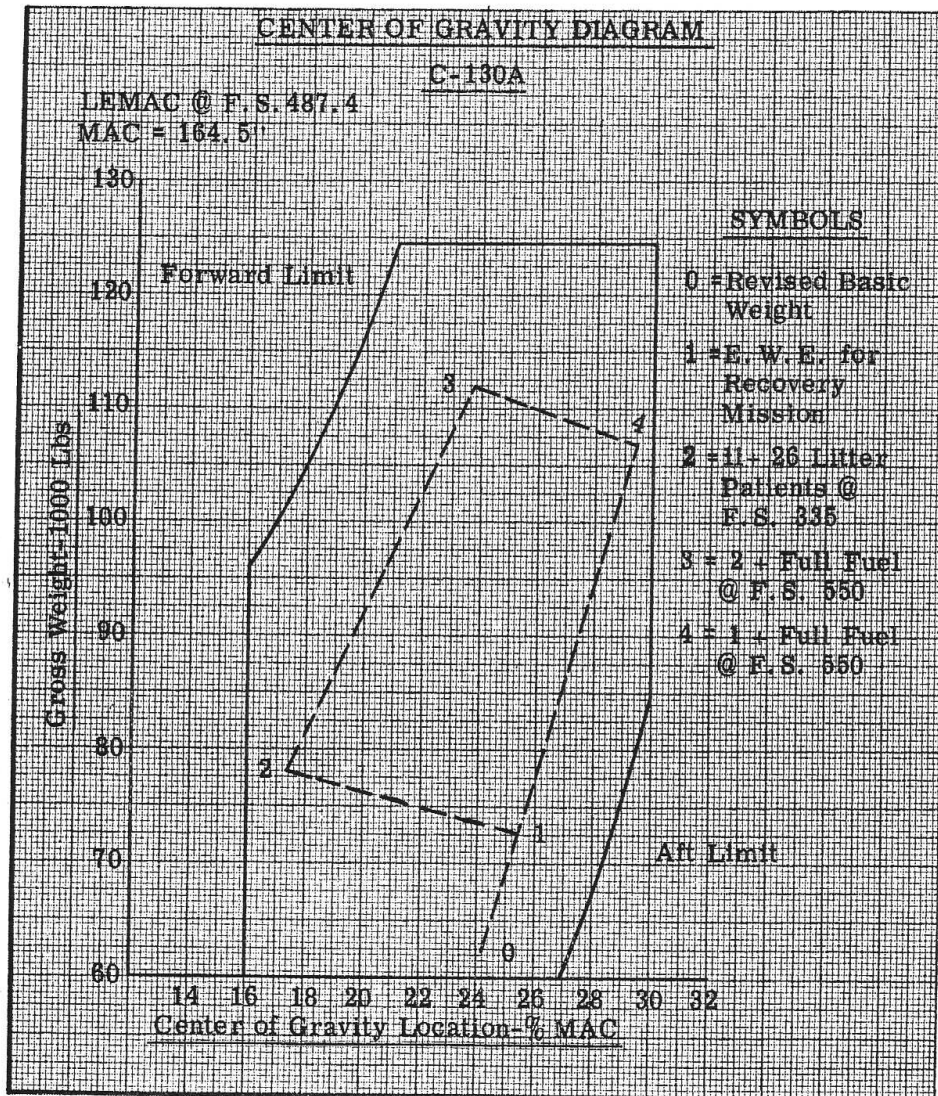

V - RECOVERY SYSTEM OPERATIONAirplane Performance

The capability of the C-130A and C-130B to perform the aerial recovery mission is demonstrated in Figure 2 which shows the variation of time-on-station with mission radius for maximum fuel. These curves reflect an increase in drag coefficient of approximately 0.0020 as compared to the basic C-130 airplane, resulting from the installation of the pickup equipment on the nose. Time-on-station is computed using operating conditions of 125 knots equivalent air speed at sea level with the cargo ramp door open causing an additional increase in drag coefficient of 0.0100. The allotted time for each pickup is 15 minutes. Airplane equipped weight empty varies with time-on-station inasmuch as the number of aerial pickups (varying with time) influences the amount of equipment carried in the airplane. The rules used in developing Figure 2 are in accordance with performance specification MIL C-5011A with regard to take-off and reserve allowances, fuel consumption conservatism, and descent consideration.

A typical aerial recovery mission profile for the C-130B is presented in Figure 19 for the aerial pickup of two men. The airplane takes off and climbs to cruise ceiling, cruises at cruise ceiling with normal power to a point over the pickup area, descends to sea level, negotiates pickup of the two men with a time allotment of 30 minutes, climbs back to cruise ceiling, returns to base at cruise ceiling with normal power, descends, and lands. It should be pointed out that normal power cruise at cruise ceiling very closely corresponds to a maximum range cruise. The radius

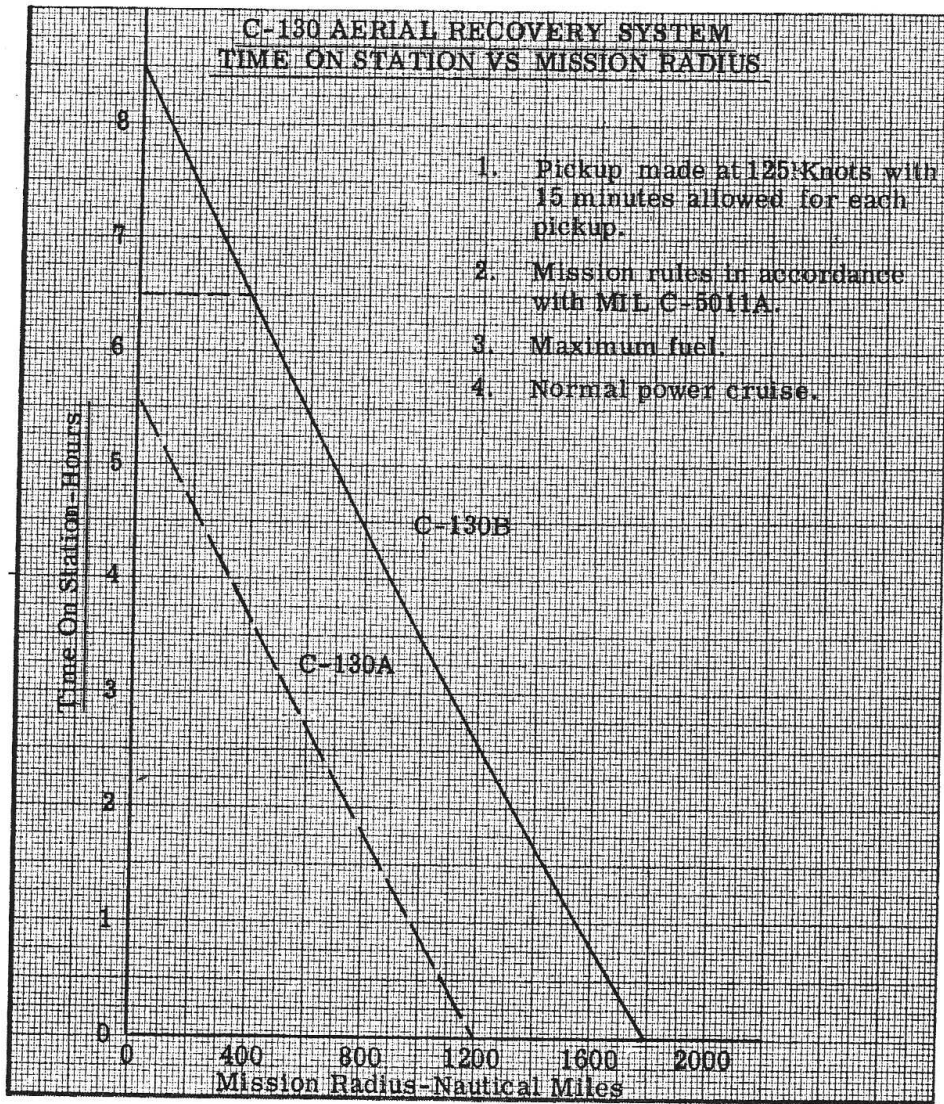

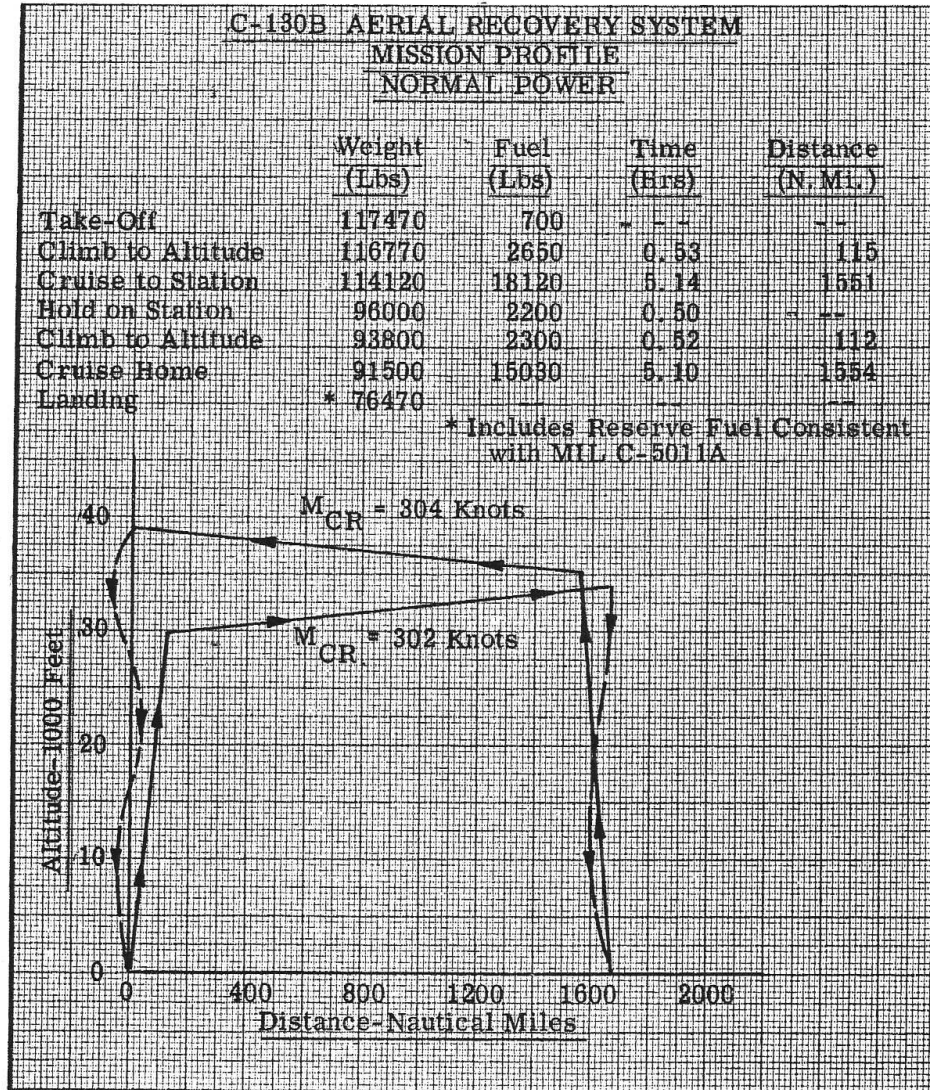

for this mission is 1665 nautical miles.

Figure 20 shows the C-130A and C-130B stall speeds as a function of weight. This figure is presented to show the pickup speed capability of these airplanes. It can be seen that the assumed pickup speed of 125 knots represents a comfortable margin over stall speed in both the clean and half-flaps configurations for the weight range encompassing the majority of aerial recovery operation (90,000 to 110,000 pounds).

Other items of C-130A and C-130B performance such as take-off, landing, and rates of climb are not shown since the differences between the aerial recovery versions and the basic airplanes are insignificant. References 2 and 3 present a complete performance analysis for the C-130A and C-130B respectively.

Operational Sequence

After the pilot locates the survivors, individual personnel survival and aerial retrieving kits are paradropped up wind of the survivors. The kits are dropped from the paratrooper doors, and the chutes are automatically opened by attachment of the chute static line to the overhead anchor line or to an overhead door fitting before pushing the kits overboard.

A ground recovery team or the survivor then recovers the survival kits and sets up the necessary rigging for the aerial pickup. In the case of light cargo, a ground recovery team must attach suitable harness to the cargo, attach the nylon retrieving line to the balloon and the cargo harness, and inflate the balloon.

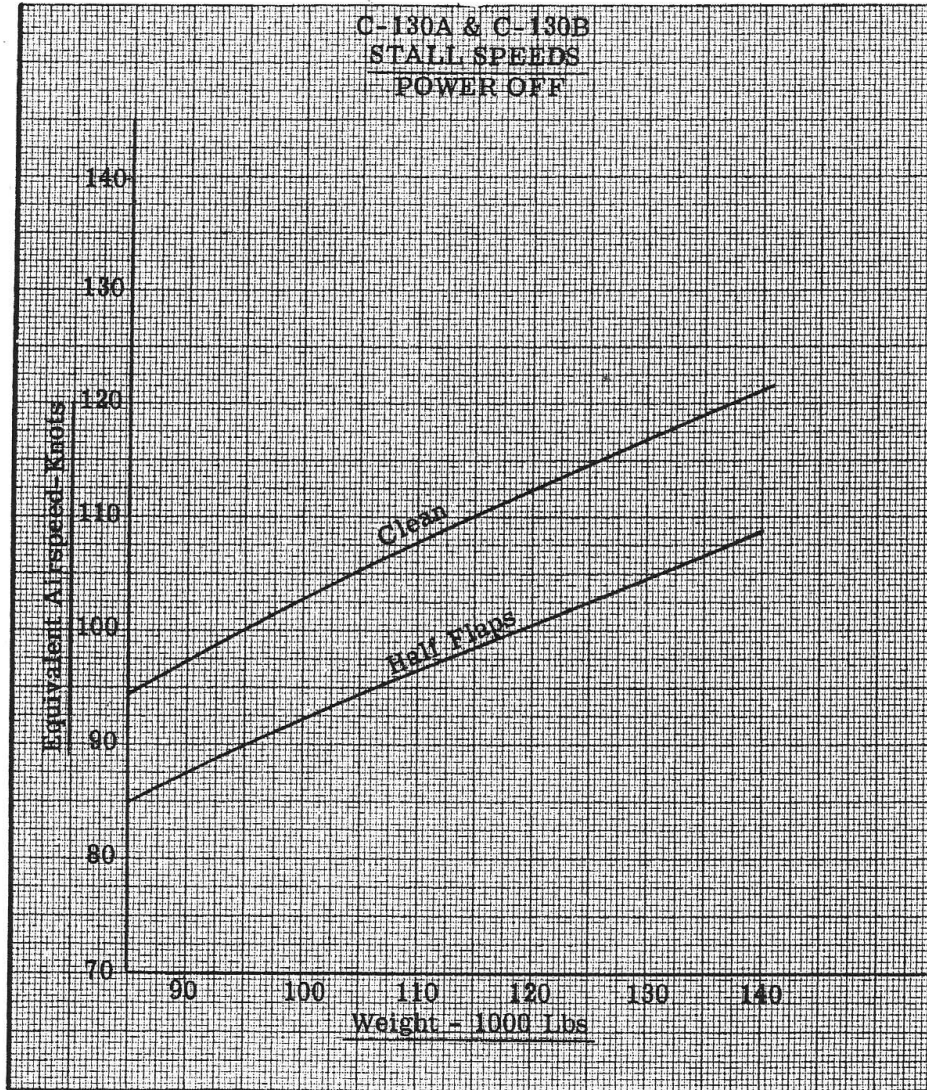

In the case of personnel, the individual dons the survival suit which contains the harness attached to the retrieving line, to which is attached the balloon. He then opens the valve on a helium tank connected to the balloon, inflating the balloon which he then releases.

After the required ground preparations are made and the pilot has made visual contact with the balloon, with or without navigational aids, he slows the airplane down to 125 knots and maneuvers to a position down wind of the balloon and retrieving rope. The aft cargo doors are then opened—the top door first, then the bottom ramp door to a position level with the cargo floor. The pallet operator lowers the hoist arm to the full-down position below the aft end of the ramp door and locks it there. He then checks the Skyhook control switches to confirm that it is cocked and ready for a pickup. The pallet operator then informs the pilot that he is ready for a pickup. The pilot then contacts ground personnel for a ready signal. Upon receiving a go-ahead, he makes his approach at 125 knots toward the balloon and into the wind. He flies directly into the retrieving line suspended under the balloon. He does not need to see the line, but merely flies directly under the balloon.

When contact is made, the yoke guides the retrieving line into the eye where it is grabbed and securely anchored by the Skyhook.

After the pickup is made, the pilot allows approximately 15 seconds for the load to stabilize, then pulls the nose of the airplane up. This operation lays the retrieving line along the bottom of the fuselage. The pallet operator then uses his retrieving bridle, or hook, as shown in

Figures 12 and 21, and lifts the retrieving line to the bottom of the airplane at the end of the ramp door. The pallet operator's assistant then attaches the snatch block to the retrieving line with the aid of the snatch block pole. After attachment of the snatch block, the assistant removes the pole from the snatch block by operating the release lever provided on the pole.

The pallet operator then operates the winch and pulls the retrieving line and snatch block through the guide pulleys on the end of the hoist, and over the guide roller at the back of the hoist, to a position between the hoist guide roller and winch as shown in Figure 22. He then attaches the pig tail from the pallet to the snatch block, backs off the winch, and disconnects the snatch block retrieving line from the snatch block.

His next step is to unwind the nylon leader line from the main drum, with the drum in free wheeling, and attach the cable clamp to the primary retrieving line as shown in Figure 23. This line goes over the guide roller on the aft end of the hoist.

He then starts the winch and winds in the retrieving line until the cable clamp goes around the drum and the retrieving line that runs forward to the Skyhook again becomes taut. He then stops the winch. After checking that the retrieving line is firmly attached to the drum, he cuts the retrieving line that goes forward to the Skyhook and attaches the free end to one of the ramp-door tie-down rings. The payload is then wound in. The operator watches the line, and when the payload approaches the end of the hoist, he slows the winch to minimum wind-in speed by operation

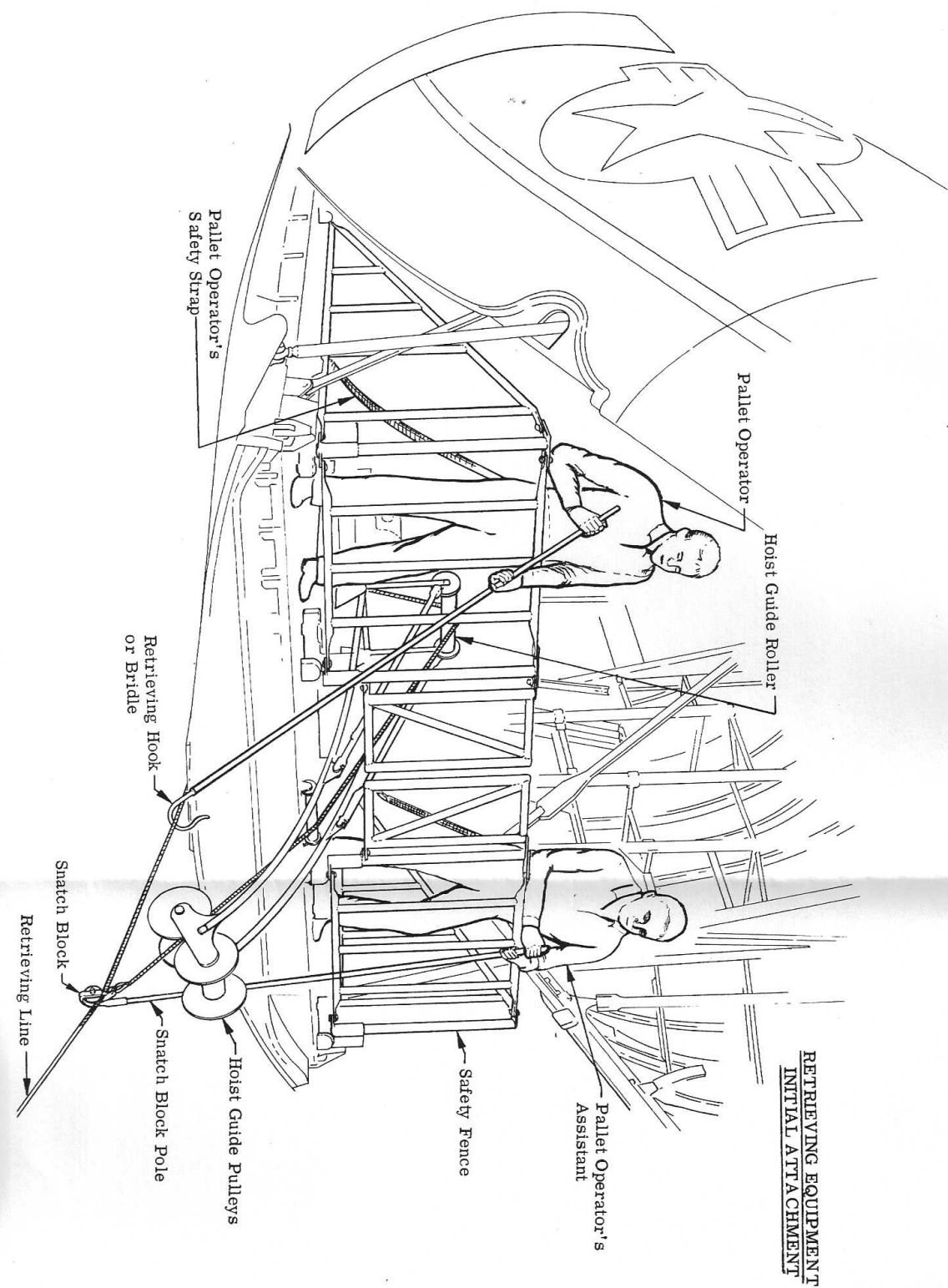

PALLET SEQUENCE - STEP 1

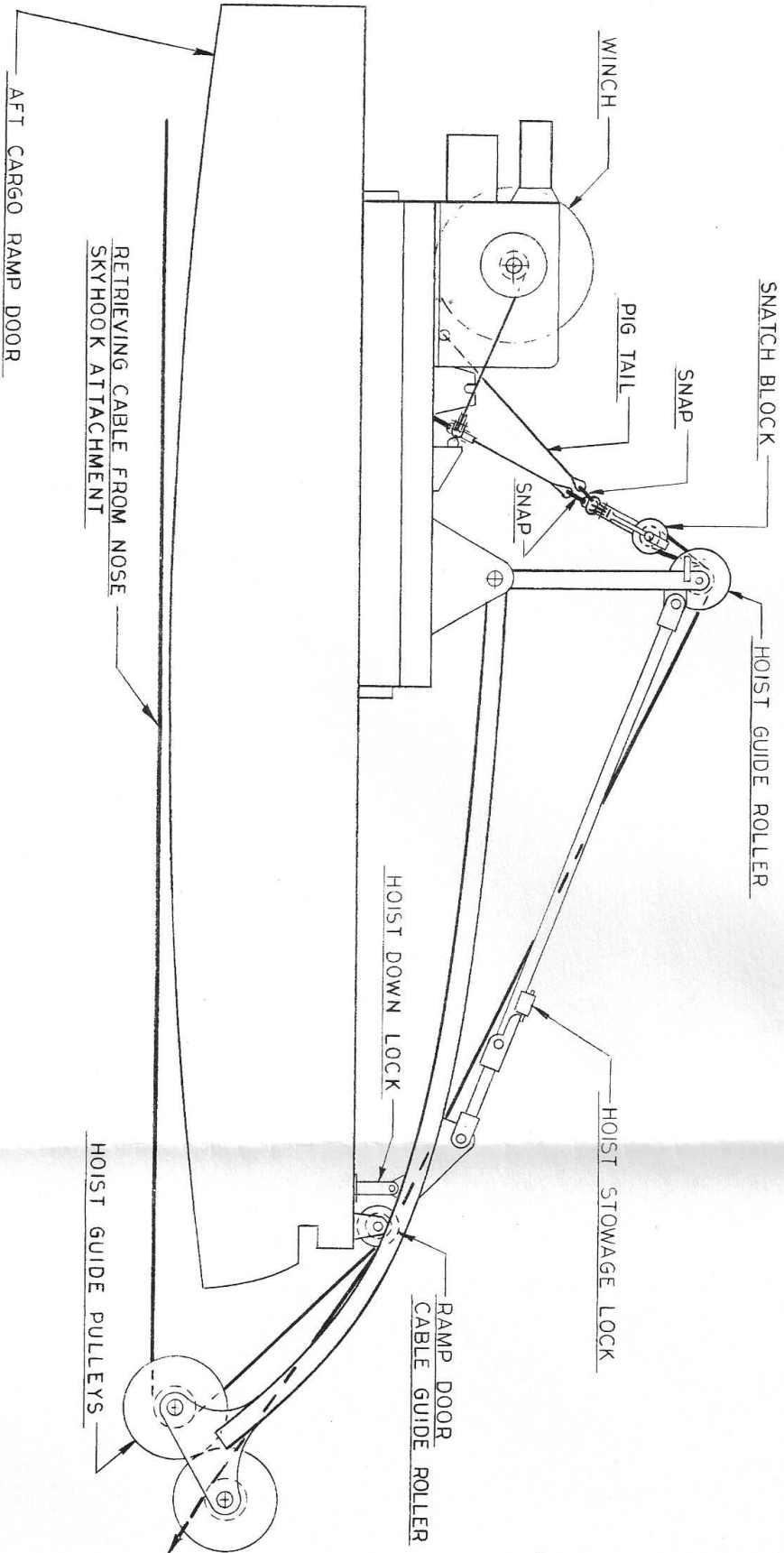

PALLET SEQUENCE - STEP II

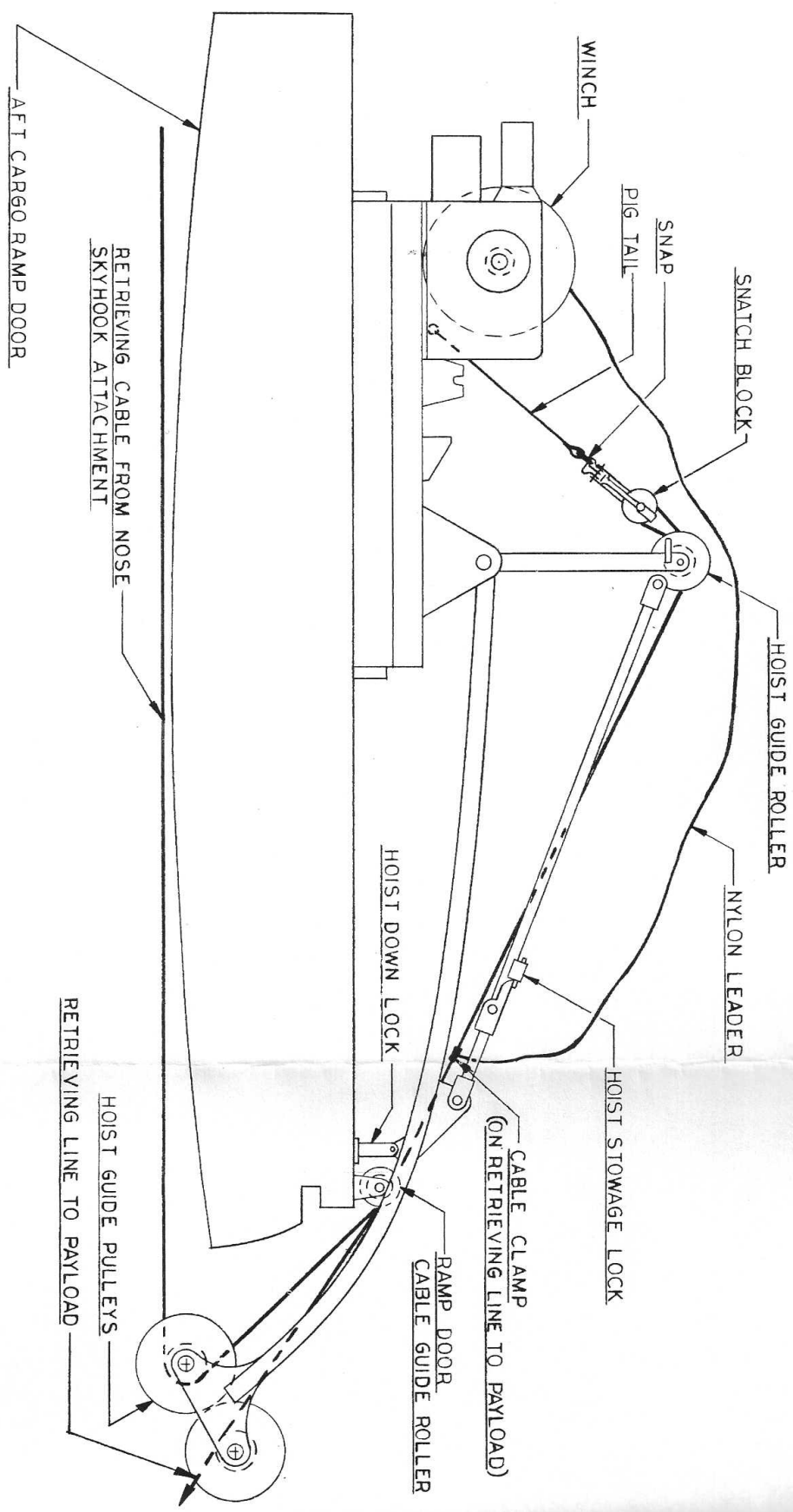

of the hydraulic flow control valve. When the cable stop, located just above the payload, comes in contact with the guide pulleys on the end of the hoist, the operator stops the winch and unlocks the hoist downlock. He then starts the winch again and the line to the winch automatically raises the hoist which lifts the load over the end of the ramp door as shown in Figure 3. The load swings on board through the safety fence gates shown in Figure 3. When the hoist engages the uplock, the winch is automatically stopped by operation of the winch shut-off valve as shown in Figure 10. The winch is then reversed by operation of the directional control valve, and the payload is lowered to the ramp floor.

Emergency retrieval or wind in of the payload, in the event of a pallet winch failure, is accomplished by using the two electric driven Aerial Delivery System pallet loading winches, located on the front bulkhead of the C-130 cargo compartment. A cable clamp is attached to the end of each winch cable, and the payload is then retrieved by attachment of one cable clamp to the nylon payload retrieving line and pulling in the load as far as possible. The process is then repeated using the other cable clamp, and by a hand-over-hand operation the payload is retrieved.

To re-rig the retrieval equipment, a spare drum is installed in place of the full drum. The snatch-block line is threaded over the hoist guide roller and through the guide pulleys on the end of the hoist. The snatch block is then attached to the line, and the pole is attached to the snatch-block.

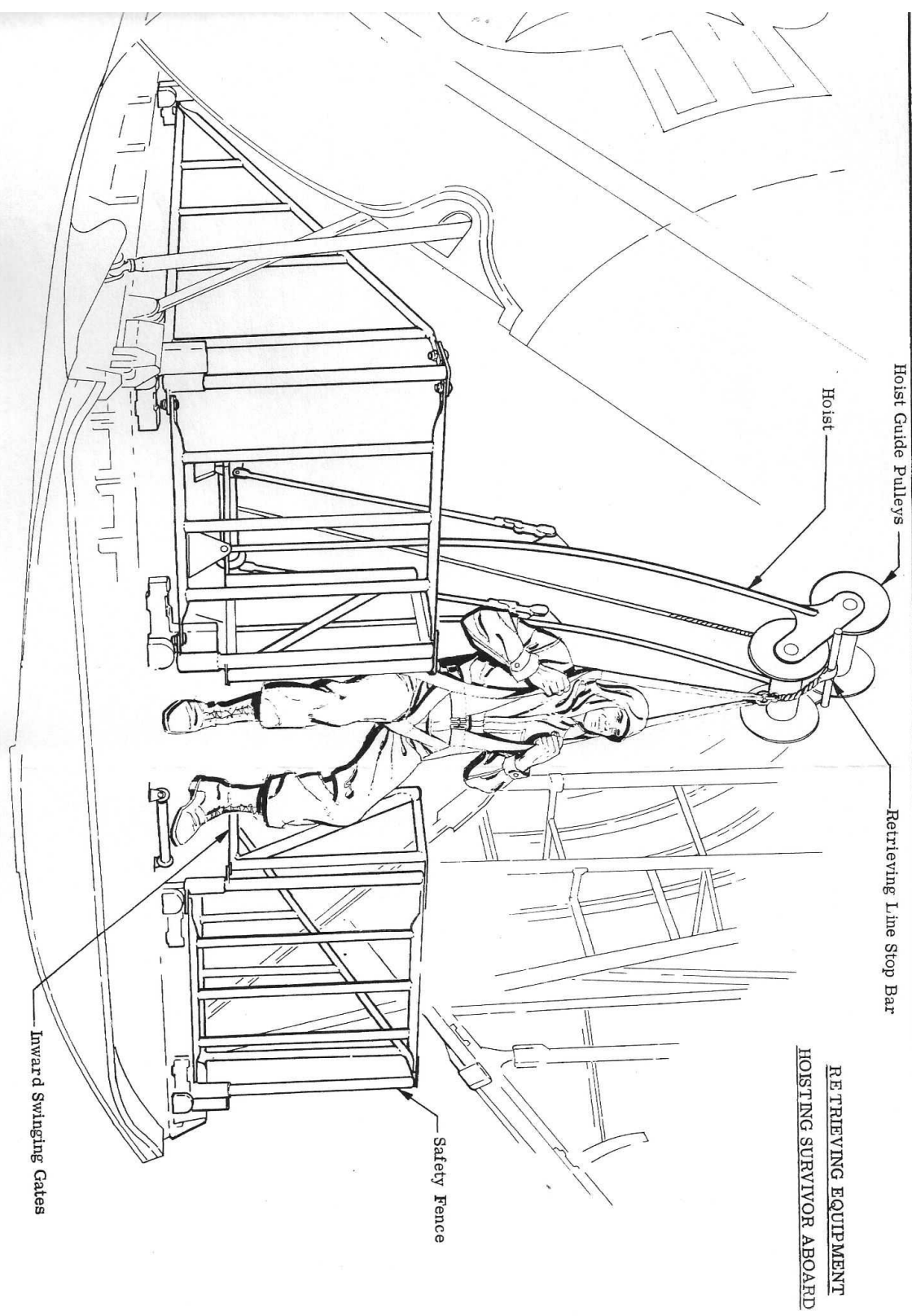

RETRIEVING EQUIPMENT
HOISTING SURVIVOR ABOARD

The pallet operator then ejects the retrieving line from the Skyhook. This is accomplished remotely by an electric motor drive which disengages the retrieving line clamps and ejects the retrieving line from the eye with the Skyhook trigger as it is pushed forward to the re-cocked position. If the line does not fall free, the pallet operator pulls on the free end which is attached to a ramp-door tie-down ring, which starts the process. The line is then released from the tie-down ring and tossed overboard. The hoist is then lowered below the aft end of the ramp door and locked in place, and the safety fence gates closed. The installation is now set for another pickup.

The repeatability of the aerial retrieving system is only limited by the number of spare winch drums and retrieving kits carried by the airplane.

Pickup Capability

The system is normally used to pick up one person at a time but structurally the system has been designed to pick up a maximum of 600 pounds which is considered to be the design limit load. Design ultimate load is 3 g's or 1800 pounds on the end of the hoist boom and 15 g's or 9000 pounds on the end of the Skyhook and supporting truss. The hydraulic system and winch motor have been sized only for the 600-pound design limit load. This gives the system the capability of multiple pickups of three 200-pound men or equivalent cargo. Multiple pickups consists of more than one item or person attached to the same retrieving line at adequate spacing. Since the feasibility of multiple pickups has

only been proven with animals at this time, it is judged that multiple pickups of human beings will not normally be used until thoroughly tested. The system has been designed, however, so that multiple pickups of humans can be accomplished when shown to be practical.

Operational feasibility tests have demonstrated that the system is capable of making pickups at night with no difficulty. This is accomplished by placing strobe lights on the balloon and retrieving rope. These can be triggered either by the intercept aircraft or by ground personnel when it is necessary to minimize detection time in a pickup in a hostile area.

Additional aid in locating the balloon at night or in low visibility conditions can be obtained by operation of the AN/APN-59 nose search radar system on the C-130B or the AN/APS-42A in the C-130A. A 10.8-foot-diameter aluminized retrieving cable balloon can be detected up to 33 nautical miles away.

It has also been proven by operational feasibility tests that pickups can be made from adverse terrain, such as mountains, forest, water, ice, and snow. Rescues can safely be accomplished from areas of less than 100 square feet, surrounded by obstructions as high as 100 feet. Since the payload goes virtually straight up, the size of the clearing becomes a function of the wind velocity, which determines the angle of the retrieving line in relation to the ground and surrounding obstructions, and subsequently the path of the payload as it is retrieved.

Pickups can also be accomplished from high seas since they only pull the balloon up and down and a definite airplane intercept position or distance from the balloon is not required as long as the intercept is made below the balloon.

Protection and Safety

Inherent in the C-130 Fulton Skyhook Aerial Recovery System are various features which provide for optimal safety of personnel. The basic considerations pertinent to personnel safety, which are discussed in the following section, are the physiological effects of pickup, the wind and weather protection provided, and the system reliability.

Physiological Effects of Pickup - Probably the fundamental question pertinent to the feasibility of a personnel recovery system of the Skyhook type is the effect of the induced acceleration forces on the human body. In this respect, it has been demonstrated in numerous test recoveries that the acceleration forces of the Skyhook system are well within human tolerance levels. The recorded acceleration levels have ranged from 4.5 g's to 10.2 g's with a mean of 5.5 g's. The relatively low shock characteristics of a Skyhook pickup may be illustrated by comparing the Skyhook acceleration forces with those of typical parachute opening shocks. This comparison is made in Figure 4. It should be noted that parachute acceleration forces may range up to three times those of a Skyhook recovery. Rate of onset of the Skyhook system forces, however, is much lower than that of a parachute opening. Nevertheless, the Skyhook forces considered over time do not exceed the human tolerance

ACCELERATION PROFILES

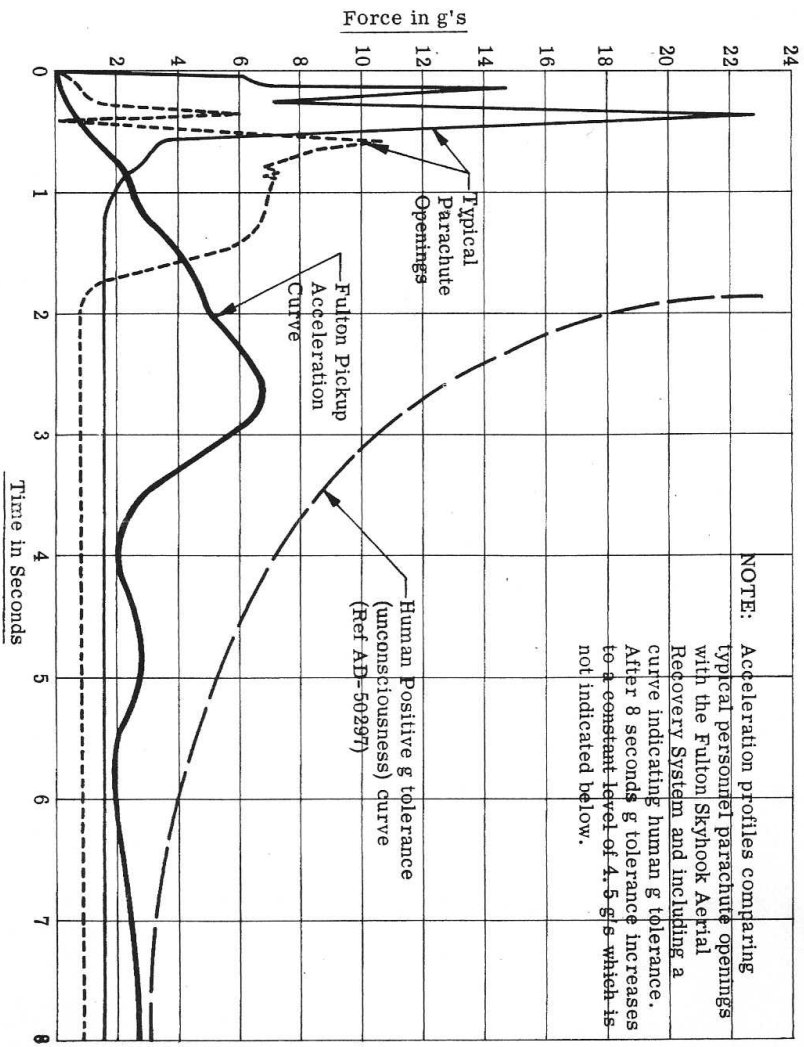

curve (unconsciousness) as shown in Figure 4. It should be noted that g tolerance level after a duration of eight seconds increases, due to circulatory mechanisms, to 4.5 g's. This portion of the curve is not shown in Figure 4. Thus, the low level relatively constant g forces during the reel-in operation are also well within human tolerance.

In order to provide for minimal shock of pickup, the line length from point of intercept to the man should be as long as practicable. To facilitate the pilot's task in making an optimal intercept, i. e., close to the balloon, the line is marked with white and orange intercept flags directly below the balloon. Under night operations, this position is marked by strobe lights energized either by the intercept aircraft or by the man on the ground. Neither line length nor aircraft speed is highly critical within the normal fluctuations of actual operation. Thus, the system inherently reduces the possibility of the application of harmful acceleration forces.

It should also be noted that during the reel-in operation the man is aerodynamically stable. Thus, there is no tendency for him to spin or tumble. He maintains his orientation and feels only slight sensations of motion.

Wind and Weather Protection - Since the Skyhook system is capable of operation under extreme climatic conditions, windblast protection of personnel must be provided. This protection is provided by several accessory items dependent on the conditions described below.

Under all operating conditions the man will be provided with a standard protective flying helmet, Type P-4 without headphones, for head and eye protection. Sufficient body protection for most operations is provided by the quick-donning anti-exposure suit into which the harness assembly is sewn. For extreme cold weather pickup additional protection may be required. It should be noted that the 125 knot windblast during a five-minute reel-in will make the effects of low temperatures particularly severe (e. g., 25° F with high winds is equivalent to less than -40° F). The additional protection is provided by a rubberized nylon windscreen draped around the man in a cape-like manner as shown in Figure 24. The screen at its upper end contains a hinged ring which is snapped and sealed around the line prior to pickup. The screen is then closed and sealed by means of a rubberized zipper seal extending from top to bottom.

Safety and Reliability - The Skyhook system includes numerous features which assure the safety and reliability of each recovery. For example, the harness assembly is a conventional military standard personnel parachute harness. In this manner the system incorporates the high inherent safety factors of military parachute equipment. The harness is modified so as to automatically tighten on load application and thus does not require individual adjustment.

The nylon line is coupled or joined where necessary by means of a special safety knot termed a Chinese finger. The purpose of this type of knot is to prevent weakening of the nylon line from heat generated by rapid tightening of conventional knots upon load application. The Chinese

EXTREME COLD WEATHER RECOVERY WINDSCREEN

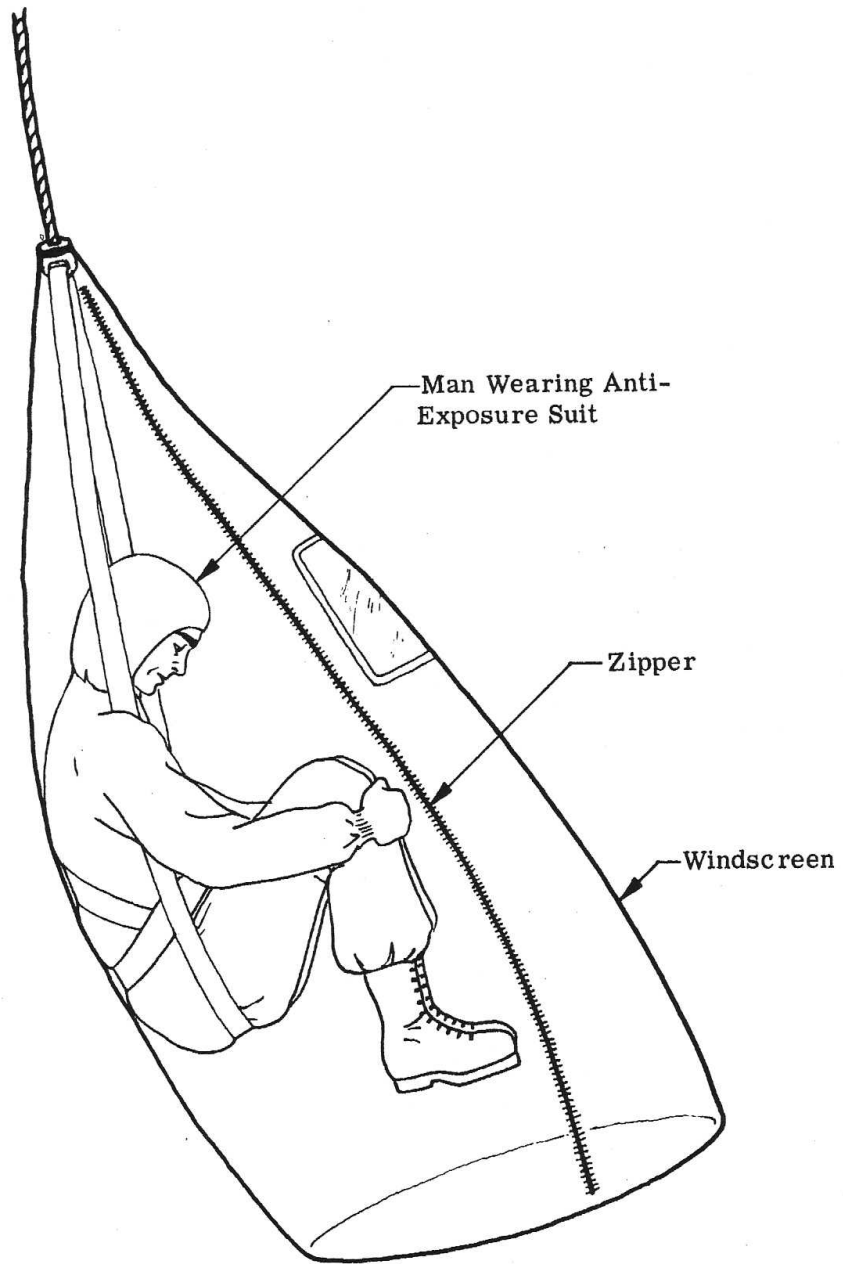

finger consists of a loop with the line pulled back inside itself (the line is hollow) for approximately 12 inches. At this point, the end is pulled through the section and served. Special machined couplings have been designed for use with this type of knot. In addition, all clips and other quick fasteners are safetied to prevent accidental opening.

It might also be noted that a missed intercept of the line, an infrequent occurrence, does not present any particular safety problems. If an intercept is missed, the guard lines on the aircraft prevent fouling of the nylon line on aircraft structure or propellers. The man feels only a gentle tug.

Numerous tests have also demonstrated that body position at time of intercept is not important provided that acceleration forces are positive or transverse. However, the preferable position is a sitting position facing the approaching aircraft with hands on legs.

One of the outstanding features of the Skyhook system is the payload's near vertical trajectory for the first 100 feet on pickup. This is an important safety feature which also provides operational advantages; thus, recoveries can be made quite close to adjacent structures, trees, or other objects without fear of injuring personnel.

REFERENCES

1. Skyhook - An In-Flight Rescue System. Newtown, Connecticut: The Robert E. Fulton Company.
2. Performance, C-130A, ER-3169. Marietta, Georgia: Lockheed Aircraft Corporation, Georgia Division, March 24, 1959.
3. Dickinson, E. R. and Moses, E. R. Performance, C-130B, ER-3339. Marietta, Georgia: Lockheed Aircraft Corporation, Georgia Division, June 6, 1958.

File provided and hosted by Entropic Memes, <http://www.slugsite.com>, August 2008.

Original report provided by the Air Force Historical Research Agency, Maxwell AFB