

THE A-10 THUNDERBOLT AS AN
ORGANIC ARMY ASSET

A thesis presented to the Faculty of the U.S. Army
Command and General Staff College in partial
fulfillment of the requirements for the
degree

MASTER OF MILITARY ART AND SCIENCE

by

MICHAEL N. RILEY, MAJ, USA
B.S., United States Military Academy, 1978

Fort Leavenworth, Kansas
1991

Distribution is unlimited; 1 June 1991. Other requests for
this document must be referred to: HQS, CAC & Ft. Leavenworth,
ATTN: ATZL-GOP-SE, Ft. Leavenworth, Ks 66027-6900.

MASTER OF MILITARY ART AND SCIENCE
THESIS APPROVAL PAGE

Name of candidate: Major Michael Neal Riley
Title of Thesis: The A-10 Thunderbolt As An Organic
Army Asset

Approved by:

Steve R. Baribeau, Committee Chairman
LTC Steven R. Baribeau, MMAS; M.A.

Billy W. Stephan Jr., Member
MAJ Billy W. Stephan, M.A.S.

Robert W. Duffner, Member, Consulting
COL Robert W. Duffner, Ph.D. Faculty

Accepted this 7th day of June 1991 by:

Philip J. Brookes, Director, Graduate
Philip J. Brookes, Ph.D. Degree Programs

The opinions and conclusions expressed herein are those of the student author and do not necessarily represent the views of the U.S. Army Command and General Staff College or any other governmental agency. (References to this study should include the foregoing statement.)

ABSTRACT

THE A-10 THUNDERBOLT AS AN ORGANIC ARMY ASSET by MAJ Michael N. Riley, USA, 154 pages.

This study concludes that the Air Attack Team Regiment (AATR), as a part of the corps aviation brigade, is the option that provides the Army with the best utilization of the A-10. The AATR combines the two main elements of a highly successful combat team- attack helicopters (AH-64's) and A-10's- into one organization.

The study investigates three options for the implementation of H.R. 4739 that directed the transfer of the A-10 into the Army. The three options are: 1) Status quo with the Air Force continuing to provide close air support (CAS) to the Army, and the A-10 would replace the OV-1 as a surveillance platform. 2) The formation of a U.S. Army Close Air Support Brigade (CASB) as proposed by the 1989 TRADOC study for assuming the entire CAS mission. 3) The formation of a U.S. Army Air Attack Regiment that combines AH-64's and A-10's into one unit under the corps aviation brigade (CAB). This paper evaluates the three options against four criteria for conducting advanced joint air attack team (AJAAT) operations: planning for preplanned AJAAT's; planning for immediate AJAAT's; command and control; and execution.

ACKNOWLEDGEMENTS

I would be remiss if I did not thank the very special people that have made this project a reality. I must first thank my committee, particularly LTC Baribeau for taking on this project when it would have been just as easy to decline my request. His efforts were magnanimous. MAJ Billy Stephan kept me true to myself and the project. He is one of the finest Air Force officers I have ever known. Finally, COL Duffner, as the "aviation-outsider" on the team, provided a special perspective and guidance that the others could not. Thank you all very much.

Most important, I wish to thank my wife, Cyndie, and my family for tolerating those lonely nights when Dad was glued to the keyboard or his books trying to write this thesis, prepare operation orders, or read history. I love you all. This thesis is dedicated to you.

TABLE OF CONTENTS

	Page
LIST OF FIGURES	vi
CHAPTERS	
1. THE HISTORY OF CLOSE AIR SUPPORT DOCTRINE AND AIRCRAFT	1
2. THE MULTI-FACETED THREAT TO AJAAT OPERATIONS	32
3. THE ADVANCED JOINT AIR ATTACK TEAM	53
4. OPTIONS FOR CONDUCTING AJAAT OPERATIONS	87
5. CONCLUSIONS AND RECOMMENDATIONS	127
APPENDIX	
A. REVIEW OF LITERATURE	130
B. GLOSSARY	140
BIBLIOGRAPHY	143
INITIAL DISTRIBUTION LIST	153

LIST OF FIGURES

- FIGURE 1: SA-7/14 LOCATION IN A MRR
- FIGURE 2: SA-9, SA-13, AND ZSU-23-4 EMPLOYMENT
- FIGURE 3: DIVISIONAL REAR AREA COVERAGE
- FIGURE 4: THREAT AIR DEFENSE SYSTEMS CAPABILITIES
- FIGURE 5: MI-24 TACTICAL MISSIONS
- FIGURE 6: HIND ATTACK PROFILE
- FIGURE 7: OPERATIONAL WINDOW
- FIGURE 8: A-10 AND APACHE UNIT LOCATIONS
- FIGURE 9: THE ATTACK HELICOPTER BATTALION
- FIGURE 10: CORPS AVIATION BRIGADE
- FIGURE 11: A-10 TACTICAL FIGHTER WING ORGANIZATION
- FIGURE 12: A-10 GENERAL ARRANGEMENT DIAGRAM
- FIGURE 13: AIR FORCE TACAIR REQUEST CHANNEL
- FIGURE 14: AJAAT SPECIFIC COORDINATION
- FIGURE 15: AIR FORCE IMMEDIATE AIR REQUEST NET
- FIGURE 16: THE CLOSE AIR SUPPORT BRIGADE
- FIGURE 17: THE CORPS AIR ATTACK TEAM REGIMENT
- FIGURE 18: SUMMARIZED OPTION ANALYSIS

CHAPTER 1
THE HISTORY OF CLOSE AIR SUPPORT
DOCTRINE AND AIRCRAFT

INTRODUCTION

On the 20th of July 1990, the United States Senate introduced Senate Bill 2884. This was the Senate's version of the Fiscal Year 1991 Department of Defense appropriation authorization. On page 245 of that document the Senate directed:

The Secretary of the Military department concerned shall notify the Secretary of the Air Force at the time each such aircraft (OV-1 and OV-10) is retired, and the Secretary of the Air Force shall upon notification, transfer one A-10 aircraft and all required support equipment to such military department.¹

The Senate's edict became national law on 4 November 1990, under Section 1439, 1990 H.R. 4739. The outcome of the final appropriations authorization is militarily and politically revolutionary, because Congress mandated a transfer of property from the Air Force to the Army. What is equally important is that Congress did not specify for what purpose this transfer was mandated. What was left unsaid is truly germane to this paper.

The Congress has been deeply involved in the interservice dispute over control of assets that support the ground commander's fight. Those assets included airplanes and helicopters. Members of Congress sometimes played mediator

and sometimes instigator in that dispute. But before exploring the recent aircraft transfer issue, a review of the forty-seven years of infighting between the Army and Air Force over Close Air Support (CAS) is necessary and relevant to determine how Congress arrived at Senate Bill 2884. The Senate's decision to transfer aircraft from one service to another underscores how the history of the close air support issue led to the development of weapon systems to conduct close support and attack missions.

HISTORICAL BACKGROUND

The history of close air support, and the relationship between the Army and Air Force is one wrought with controversy resulting from congressional interference and service parochialism. The controversy is now, and has been, the execution and control of close air support, and its responsiveness to the ground commander.

Close air support first became a serious issue during World War II (WWII). In 1943, the Assistant Secretary of War, John McCloy, commenting on CAS operations in North Africa stated:

It is my firm belief that air forces are not interested in this kind of work, think it is unsound, and are very much concerned lest it result in control of air units by ground forces. Their interest, enthusiasm, and energy are directed to different fields.²

This attitude seemed to prevail throughout World War II (WW I) and in the 1950's, despite the emergence of a

two-mission air force: one used for strategic bombing, and the other for support of the ground armies. Army Colonel Jules E. Gonseth, the Deputy Commandant of the Army Aviation School in 1955, noted that despite the doctrinal change to centralized control-decentralized execution for Army Air Corps assets, during 1944 only 8 percent of the Eighth Air Force's missions were tactical. The Tactical Air Command, whose primary mission was "close air support," only allocated one-third of their available sorties to their primary mission.³ Gonseth truly reflected the parochial prejudice of Army versus Air Force aviation. His comments were only loosely based on facts, and only stirred the on-going controversy rather than help end it.

The Air Force was officially born with the signing of the National Security Act of 1947. The act did not assign missions or roles to the services, but it did broadly suggest that the Congress could delineate the scope and function of the services. The act also provided for unspecified organic Army aviation.

Without clear language, each service chose to interpret the National Security Act as they deemed appropriate. Almost immediately following the separation, the Army had a "powerful and growing impulse to build up organic aviation resources"⁴ that it could deploy in accordance with its own concepts of joint-air ground operations. This desire stemmed from the fundamental issue of controlling one's own destiny

through the owning and operating of their own aircraft. What followed was nearly a half century of directives and memorandums aimed at defining and delineating each service's role in the close air support mission. The first of these was the Key West Agreement.

The Key West Agreements of March 1948, between Secretary of Defense James Forrestal and the Joint Chiefs of Staff, and approved by President Truman, resulted in the issuance of the Department of Defense Directive (DOD) entitled "Functions of the Armed Forces and the Joint Chiefs of Staff." This document sought to establish missions and roles for the services, and reiterated the Army's role to include "land combat and service forces, and such aviation and water transport as may be organic."⁵ This very broad mission statement was not favorably received by the Air Force or Navy.

Almost before the ink was dry on the Key West Agreement, the Newport Agreement of August 1948 sought to clarify the unpopular Key West Agreement. The result was another DOD directive that established the "exclusive responsibility" of each service for programming and planning the primary mission areas assigned to them.⁶

Between September 1947 and July 1949, by authority of the National Security Act of 1947, the Army transferred nearly all of its aviation assets including personnel, functions and facilities to the Air Force. Towards the end of this period the Secretaries of the Army and Air Force met and reached an

accord on the types and numbers of aircraft the Army could have. The agreement, known as the Bradley-Vandenburg agreement, limited the Army to fixed-wing aircraft not exceeding 2500 pounds in weight, and helicopters weighing no more than 4000 pounds. That agreement also delineated the aviation responsibilities for the Air Force and the Army. The Army missions were altogether non-combative, and included aerial route reconnaissance, local courier service, emergency aerial evacuation, and limited aerial resupply.⁷

In 1952 the Secretaries of the Air Force and Army signed the Pace-Finletter Agreement which sought to more clearly draw the line between the services based on mission or function rather than aircraft gross weight. The agreement stipulated that Army aircraft would be used "for the purpose of expediting and improving ground combat; subject, however, to the limitation that such aircraft will not duplicate the functions of the U.S. Air Force." Clearly, close air support was implied as a mission not to be duplicated; however, the Army helicopter mission list was expanded to now include movement of "supplies, equipment and small units within the combat zone."⁸

Post-WWII saw the Air Force expanding its strategic capability at the expense of their CAS mission. The Air Force's newest jets, the F-84 and F-86, were designed for air-to-air combat first, and CAS second. Atrocious fuel consumption at low altitudes severely limited loiter time.

Additionally, air-to-ground communications continued to deteriorate. As late as the second year of the war, soldiers on the ground often could not communicate with the fighter aircraft because the frequency range of the radios was incompatible. The result was response times ranging from 20 minutes to several hours between request and ordnance delivery.⁹ Without communications, CAS could not be conducted near troops, obviously creating a void in support. Eventually compatible radios were developed and deployed and the Air Force continued to provide airlift and CAS to ground forces during the Korean conflict.

The Air Force considered the Korean conflict an aberration. The Korean conflict did not fit the strategic nuclear war model. Secretary of the Air Force Thomas K. Finletter wrote that the war had been "a special case, and air power can learn little from there about its future role. . . in the East."¹⁰ It was during the Korean conflict, however, that the Army realized the potential of the helicopter and openly began to expand its helicopter fleet and role.

In 1953 the Army began training its own helicopter pilots, and in 1954 established Fort Rucker, Alabama as the Army aviation training center. Then in 1956 the Air Force relinquished primary and advanced fixed-wing and helicopter crew training mission of Army pilots to the Army. It was also during this time that the Army knowingly or perhaps unknowingly pulled one of history's great hoodwinks. They notified

the Air Force that the Army no longer had a requirement for helicopter assault squadrons. As a result, the Air Force deactivated their eleven assault squadrons, relegating their helicopters to administrative and logistical support missions. Soon thereafter the Army reinstated the requirement for the helicopter assault squadrons, and proceeded to create their own helicopter assault units.¹¹

By the end of the Korean War, the debate over providing aerial support was as intense as ever. DOD issued yet another edict titled Department of Defense Directive 5160.22, Clarification of Roles and Missions of the Army and Air Force Regarding Use of Aircraft. The directive charged the Air Force with providing close combat and logistical air support to meet reasonable Army requirements. The Army was permitted to own and operate aeromedical evacuation aircraft, liaison, and observation aircraft in the combat zone, but was expressly forbidden from conducting tactical reconnaissance, tactical airlift, interdiction, or close air support.¹² This was the first document that clearly specified the CAS responsibility for the Air Force based upon the needs of the Army, and was critically important for the future development of CAS systems.

Inter-Service parochialism in the late 1950's and early 1960's continued to hamper the joint development of doctrine and aircraft to conduct the CAS mission despite specific guidance given by the Joint Chiefs of Staff (JCS). In 1959

the JCS published a document called the Unified Action Armed Forces. In it, they again tasked the Air Force with providing CAS to the Army, plus they added the requirement for developing doctrine, equipment, and tactics and techniques for conducting CAS.¹³ Six years later in 1965, the Air Force finally published their document entitled "Doctrine For Close Air Support of Land Forces", and released it for review and approval by the other services. More than five years after releasing the document, the Air Force had not received approval signatures from the other services.¹⁴

The Air Force entered the Vietnam War unprepared to conduct CAS. They borrowed 25 L-19 light observation aircraft from the Army to serve as forward air controllers (FAC's), and they borrowed A-1 Skyraider aircraft from the Navy to perform CAS. They also had to convert their primary jet trainer, the T-37, into a CAS platform.¹⁵

The Army entered the conflict with more than 5000 aircraft evenly split between fixed-wing and helicopters. By 1965 the total exceeded 7600 with more than two-thirds being helicopters. These included heavy-lift and armed helicopters, and armed OV-1 Mohawks (a fixed-wing aircraft).¹⁶ The Army continued with their own development of close support and air-lift helicopters.

The Army's push into the Air Force's domain was fueled by a 1965 memorandum that Secretary of Defense Robert S. McNamara sent to General John L. McConnell, the Chief of Staff

of the Air Force. McNamara felt that any aircraft that was participating in a conflict area should be armed not only for self-defense but also to contribute to the ground force fight. Additionally, he considered the Army's development of antitank and other weaponry for helicopters as quite appropriate.¹⁷

McConnell met with Army Chief of Staff General Harold K. Johnson, and the Johnson-McConnell Agreement followed. It was the result of intense negotiating between the Army and Air Force, and required the Army to turn over their heavier CV-2 "Caribou" transports to the Air Force. In return the Air Force relinquished all claims to the Army's helicopters including gunships used for "aerial fire support."¹⁸ The gunships referred to were modified UH-1's known as B's and C's that carried a mix of rockets, machine guns, and grenade launchers.

The Army continued to rapidly develop "close support" attack helicopters. In 1967 the Army fielded the world's first attack helicopter, the AH-1G "Cobra," in Vietnam. The Cobra carried a mix of 2.75 inch folding fin aerial rockets (FFAR) and multi-barreled machine guns. Because it was deployed near the troops it supported, the Cobra could spend longer time over the target area, and usually expended all of its ordnance before reaching its fuel limit.

The Cobra was a temporary fix for the Army to reduce their dependence on Air Force CAS in Vietnam. The helicopter,

under the direct control of the Army, provided the ground commander at all levels with timely, accurate, and responsive target suppression. The Cobra and its role was a clear violation of all previous agreements and accords, but was acquiesced because of McNamara's memo and the Johnson-McConnell agreement. Concurrently in 1967, the first flight of the AH-56 "Cheyenne" took place.

The Cheyenne was the planned follow-on to the Cobra, and was highly touted as a close support weapons system. It was a true "compound-helicopter," because it was capable of generating aerodynamic lift horizontally and vertically. The Cheyenne had a conventional main and tail rotor, but also had a "pusher-prop" mounted on the vertical tail fin that provided thrust in horizontal flight. Also the weapon-station wings were actual lifting surfaces just like the wings on a conventional airplane with ailerons added for maneuverability.

The Air Force was deeply concerned about the Cheyenne's capabilities, and the Army's increasing encroachment into the CAS arena. They sought to have it reclassified from a compound-helicopter to a "converti-plane."¹⁹ A converti-plane lifts-off in the vertical mode and then transits to horizontal flight. This was the first attempt to quantify the vertical take-off and landing (VTOL) aircraft. This reclassification would then place the aircraft under Air

Force control. (That reclassification plan was never ultimately decided, and ended with the demise of the Cheyenne program in 1971.)

In 1968, Secretary of Defense McNamara authorized the purchase of 375 Cheyennes for the Army. That single act pushed the Air Force into the development of a single-role CAS aircraft.²⁰ They labeled their aircraft program the A-X.

The development of the A-X was as much in response to the need for a single-role CAS aircraft as it was in response to the threat perceived by the Army's AH-56. In 1970, Air Force Secretary Robert Seamans told Congress that "we in the Air Force have been negligent in not bringing along such a plane [the A-X] sooner."²¹

For the next two years political infighting continued between the Congress and the services as to which aircraft system or systems should be developed, and the missions that each should conduct. Congress was especially concerned about apparent overlapping missions between the A-X and the AH-56. Congress felt that the AH-56 and the A-X were both designed to conduct CAS, and were consequently reluctant to fund both aircraft despite assurances from both services that both aircraft were needed.²²

Also during these two years two key events took place that were to have a profound effect on the CAS issue. On March 8, 1971, for unknown reasons, the Department of Defense quietly rescinded DOD Directive 5160.22, which had restricted

the Army from performing close air support.²³ The other was the formation of the Packard Commission in March 1971 by Deputy Secretary of Defense David Packard. Packard charged his commission with providing Congress with:

...a clear picture of the diversity and importance of the close air support missions, of the threat environments in which they must operate, of the extent to which our present systems are capable of discharging these missions, and the expected costs, schedules and intended uses of the new systems under development...²⁴

In 1971 the Air Force initiated a Rand Corporation study to delve into and assess the CAS issue. The study examined the history of the CAS mission, the disputes between the services over conducting CAS, and the control of the CAS mission. One of the key findings of the Rand study was:

There can be little doubt that the Army has established a de facto role for itself in close air support and that this role is permanent.²⁵

The AH-56 program officially ended on 9 August 1972.²⁶ The cancellation of the Cheyenne program may have been viewed as the demise of the Army CAS program. Several factors contributed to the termination of the AH-56 program, not the least of which was its untested advanced technology. These factors were: breach of contract by Lockheed Corporation, because the aircraft did not meet the maneuverability specifications; the cost overruns of the program; a new emerging Soviet threat not previously found in Vietnam; and the apparent capabilities of the A-X now designated as the A-10.

Notwithstanding was the 1971 Congressional recommendation mandating CAS responsibility to the Air Force.

The Army pushed for the selection of the A-10 for three main reasons. First was the simple, durable design that would allow the Air Force to purchase large numbers. Secondly, the aircraft was designed only as a CAS platform. Finally, the aircraft could operate from forward-based locations.²⁷

It was obvious that the Army had no intention of relying totally on the Air Force for "fires in support of close combat". Despite Congressional recommendations that the "Congress fund no new attack helicopters as a substitute for the Cheyenne"²⁸, the Army initiated the Advanced Attack Helicopter (AAH) program on 10 August 1972, the day after the Cheyenne program was cancelled.²⁹ During congressional testimony in January 1972, General Momyer, the Commander of Tactical Air Command, stated:

For almost twenty-five years the Air Force has attempted to develop close air support doctrine for joint operations. This effort, unfortunately, has met with little success and, consequently, our retention of this historical Air Force mission is being seriously challenged.³⁰

The A-10 "Thunderbolt II" entered service with the Air Force in 1977. A total of 713 aircraft were produced with the last aircraft delivered in 1984.³¹ At present, nearly 650 A-10's remain in the Air Force inventory.³² As of 30 September 1989, the average age of the 447 A-10's in the active Air

Force was 8.9 years.³³ The 197 A-10's in the reserve and national guard fleets averaged 10.6 years old.³⁴

The A-10 was designed solely as an armor-defeating CAS aircraft. The aircraft was built around the General Electric GAU-8/A "Avenger," 30 millimeter cannon. The cannon fires depleted uranium rounds at a maximum rate of 4200 rounds per minute, with a muzzle velocity exceeding the speed of sound at sea level. The A-10 can also carry Maverick air-to-ground missiles as point weapons (single weapon-specific single target), and iron bombs for area weapons (single weapon-large blast effects within the target area). Total external ordnance capacity exceeds 16,000 pounds.³⁵

Development of the Joint Air Attack Team

From the outset of its initial deployment, the A-10 was involved in a controversy between Congress and the DOD over its survivability on the mid-to-high intensity battlefield. As a result, the Department of Defense directed a series of joint tests to be conducted with the Air Force A-10 and the Army AH-1S "Cobra" attack helicopter.

The AH-1S, a growth of the AH-1G initially fielded in Vietnam, was equipped with the Tube launched-Optically tracked-Wire guided (TOW) antitank missile. The TOW missile is an antitank missile fired from the aircraft out to a maximum range of 3750 meters. The copilot/gunner (CPG) tracks

the target through a telescopic sight unit (TSU), and the missile flies to where the CPG is looking. The AH-1S carried up to eight TOW missiles depending on the weather conditions and density altitude.

The Army Training and Doctrine Command (TRADOC) and the Air Force Tactical Air Command (TAC) had joint responsibility for conducting the tests. The tests were called the Joint Attack Weapons System Tactics Development and Evaluation (JAWS TD&E). JAWS I, conducted in 1977 at Fort Benning, Georgia, and JAWS II, conducted in 1978 at Fort Hunter Liggett, California, were both conducted against actual threat systems that were either stationary or moving. One of the major test results was:

When attacking individually, the A-10's and Cobras each had approximately the same kill ratios against the threat battlefield array. However, when they attacked together, the kill ratio increased by a factor of from three to four. As important as the increase in kill ratios was the fact that at the same time the kill ratios increased, the losses of both A-10's and attack helicopters decreased.³⁶

Skeptics within the Army and Air Force were still uncertain about the survivability of the A-10 in the mid-to-high intensity battlefield. That prompted the Under Secretary of Defense for Research and Engineering to direct DOD to conduct Phase III. This phase conducted during August and September 1979, evaluated the Tactical Aircraft Survivability and Effectiveness in Close Air Support Anti-Armor Operations (TASVAL). TASVAL was at the time the largest force-on-force instrumented wargame ever attempted.³⁷ The end result of all

phases was the initial development of the Joint Air Attack Team (JAAT) tactics and procedures. JAAT represented a revolutionary growth in combat capabilities, and provided continued proof of the viability, lethality, and survivability of the A-10 on the mid-intensity battlefield when employed with attack helicopters.

Development of the Advanced Attack Helicopter

The AAH program that began in 1972 came to fruition with the initial production and fielding of the AH-64A Apache in 1984. The Apache represented unprecedented capabilities possessed by no other attack helicopter in the world. The United States Army now had the only near-all-weather, day-night attack helicopter in the world capable of destroying targets 8 kilometers away. Brigadier General (Ret) John C. Bahnsen, a 4000-hour Army aviator and a leading proponent of Army aviation, stated:

The Air Force should get out of the CAS business, with the Army appropriately expanding their AH-64 fleet. Spaces, personnel, and money to support this should be moved to the Army budget. . .³⁸

In a student report prepared for the Air Force Air Command and Staff College, Army Major William Backlund concluded emphatically that the Army could assume the CAS mission with their organic helicopters.³⁹ Similarly, Army Major Max V. Terran, in a 1982 Masters Thesis concluded that "the Army, through its armed helicopter, now has the CAS system which it has searched for and fought for since 1942."⁴⁰ In apparent

agreement with General Bahnsen, these authors chose to disregard the capabilities and enhancing qualities of the JAAT, and chose to focus on the separate systems. None of the three explored the option of combining the A-10 and Apache into a permanent organization. Also, they all defined attack helicopters as CAS platforms under the classic definition of CAS instead of as maneuver weapon systems that current Army doctrine defines them to be.

Development of Advanced JAAT

In 1987, almost by accident, a newly fielded AH-64 battalion and an A-10 squadron agreed to jointly share gunnery range time. What followed was a three-star directed test that became known as Advanced JAAT (AJAAT).⁴¹ The test was conducted with the new AH-64A and the A-10 in three phases. The results of the test required a rewrite of traditional JAAT techniques, but overwhelmingly reaffirmed the ability of the AJAAT team to fight and survive on the mid-to-high intensity battlefield. Key findings of this test were:

The AH-64 Apache employed in a mid-intensity, low-altitude AJAAT engagement, significantly increases U.S. Air Force A-10 Thunderbolt standoff ranges, eliminating the most difficult task for the A-10-target acquisition.⁴²

. . . the AJAAT can detect, identify and destroy enemy armor at ranges in excess of 7 kilometers. The AJAAT can respond better to the spontaneous battlefield.⁴³

The fact that the test was conducted as a result of individual unit initiative rather than service recognition of

potential capabilities is perhaps an indicator that the senior leadership in both services did not consider the A-10 as a capable system to incorporate with the AH-64A.

Replacing the A-10

On 22 May 1984, prior to the actual fielding of the Apache, the Chiefs of Staff of both services signed a Memorandum of Understanding (MOU) known as The 31 Initiatives. In that document Chief of Staff of the Army General John A. Wickham, Jr. reaffirmed the longstanding policy that the Air Force would continue to provide the Army with fixed-wing CAS platforms.⁴⁴ The document also included an additional Memorandum of Agreement (MOA) that specified criteria for the follow-on CAS aircraft, again designated as the A-X.⁴⁵

The Air Force and Army Chiefs of Staff stated in their MOA that they wanted the A-X to be a multi-role aircraft instead of single-role like the A-10. In 1985, the initial aircraft selected by the Air Force, a modified F-16, was rejected by the Defense Resources Board, who then required a further study.⁴⁶ The Air Force established the Close Air Support Aircraft Design Alternatives (CASADA) group to study and revise the Mission Requirement Package for the follow-on aircraft.⁴⁷

CASADA spent \$10 million in their 1988 study, and issued a classified report recommending modifying a number of A-10's and F-16's for the CAS mission. Their report was

approved by the Army and Air Force Chiefs of Staff, the Secretary of Defense, and the Defense Planning and Resources Board.⁴⁸

The CASADA report met with political resistance from Congress because some members of Congress felt that the Air Force had not been pursuing the CAS issue seriously enough. As a result, in 1989, the Congress passed Public Law 100-526. The law directed DOD to: 1) Determine all the aircraft capable of replacing the A-10; 2) Conduct a fly-off of those aircraft selected; and 3) Conduct a feasibility assessment of the Army assuming the Close Air Support mission.⁴⁹

The Air Force did not present Congress with a viable fly-off plan, and Congress reacted by suspending production funds for the F-16 until an acceptable plan was produced.⁵⁰ Despite the fact that it was public law, the Air Force had already conducted 12 CAS studies in the past ten years and did not feel another test was in the best interest of the taxpayers.⁵¹ Because the next plan was not available before the defense budget was finalized, the \$120 million dollars earmarked for modifications to the fly-off aircraft was subsequently dropped from the FY 90 budget.⁵²

SUMMARY

The last forty-seven years of interservice bickering, rivalry, and parochialism have actually come to some good. The development and production of quality aircraft in the

AH-64 Apache and the A-10 are the result of this Army and Air Force interservice rivalry. The few periods of genuine service cooperation resulted in the development of JAAT and AJAAT which offer the ground commander significantly improved combat capabilities.

Unless Congress voids or amends their own legislation, some A-10's appear headed for the Army. This restricts the Air Force's effort to control the aircraft's future. Their plans included re-rolling the aircraft into an observation platform, the OA-10, offering the A-10 for Foreign Military Sales, destroying some as fodder to comply with the conventional forces treaty that is expected to be ratified, and prematurely retiring the aircraft despite its demonstrated ability to conduct AJAAT. What remains is for the Army to effectively employ the aircraft in the manner that the aircraft was ultimately designed for.

PROBLEM STATEMENT

The A-10 is being transferred on a one-for-one basis to the Army for every OV-1 Mohawk that is retired. The OV-1 is a twin-turboprop reconnaissance aircraft. Despite the fact that it saw limited use as a close support platform in the early part of the Vietnam War, the OV-1 is not a CAS system. Likewise, the A-10 is not an aerial reconnaissance platform.

Congress authorized the transfer of the A-10 to the Army, but they did not dictate its mission. They did however,

stipulate that the GAU-8 cannon would remain installed and operational in the aircraft. Under the heading of The Principle of Full Utilization of Forces in the Joint Chiefs of Staff Publication 2 is written:

Weapons, techniques, and intrinsic capabilities of each . . . must be fully used and exploited in any military situation where this will contribute to the attainment of the overall objective.⁵³

Whether or not the Soviet Union has diminished as a threat to world peace, the United States is faced with a formidable third world threat that is often outfitted and trained by, and aligned with the Soviet Union. Latest estimates indicate that from 1980 to 1988 over 22,025 tanks and armored fighting vehicles were delivered by the Soviet Union to Third World nations.⁵⁴ Iraq alone possesses 5500 tanks and 3000 artillery pieces.

Soviet tank equipment delivered to Third World nations such as Iraq, Syria, Libya, Cuba, North Korea, and Vietnam, ranged from the vintage T-54/55 updated with reactive armor and laser rangefinders to the modern and lethal T-72 and T-80. Soviet armor vehicle production from 1986 to 1988 exceeded 8900 vehicles.⁵⁵ The defeat of these type forces is the forte of the A-10 and attack helicopter team. "JAAT's demonstrated ability to provide firepower throughout the entire width and depth of the battlefield"⁵⁶ makes this combination the single-most formidable threat-defeating team on the modern battlefield.

The invasion of Kuwait by Iraq in August 1990 again reinforced the need for a readily available, potent tank-killing team. The A-10 and AH-64 team was the best rapidly deployable offensive tank-killer team available when Iraq attacked. While the United States and their allies deployed defenses immediately to Saudi Arabia, the Air Force delayed the deployment of the A-10 for one week after the initial American deployment.⁵⁷ Failure to fight these aircraft as a team negates the 300% increase in their lethality.⁵⁸ General Michael Dugan, then the Air Force Chief of Staff, said the Iraqis have "the version of tanks that the A-10 was designed against."⁵⁹ The Air Force now touts the A-10 "as the close-air-support weapon of choice against Iraqi tanks."⁶⁰

The A-10 and AH-64 team is a highly flexible, devastatingly lethal team that can simultaneously operate in the close, rear, and deep battle and survive. Removal of the A-10 through early retirement or re-rolling would unnecessarily remove from the battlefield a potentially decisive combat system whose contribution on contingency battlefields will not be matched within the next decade.

HYPOTHESIS STATEMENT

Combining the A-10 with its entire maintenance and logistical infrastructure into the Army corps attack helicopter regiments as an Air Attack Team (AAT) is the best use of the A-10 for the remainder of its service life.

SIGNIFICANCE OF PROBLEM

This thesis is significant in part because this type of study does not presently exist in printed literature. Numerous studies have been conducted that address centralized vs. decentralized control of the close air support mission, or whether or not the Army can conduct the CAS mission with its own organic helicopter fleet. This work will use information from both of these study areas to support the thesis.

This work is also extremely significant because it advocates the one-time transfer of a major weapon system and its entire support infrastructure to another service. The A-10 was designed and built exclusively to provide close air support. Its survivability and lethality are dramatically enhanced when incorporated with attack helicopters. The average A-10 aircraft has over 10 years of expected life remaining, and should therefore be placed where it will remain most effective through its operational life.

Essential to this work will be the focus on the placement of the A-10 aircraft into an "Air Attack Team (AAT)" organization with attack helicopters, and employed on the present AirLand Battle and the AirLand Battle Future battlefield.

Several key issues will have to be addressed in order to conduct a thorough investigation. Will the transfer of the aircraft necessarily enhance the ground commander's lethality?

Is the aircraft sustainable? What organization will be the most effective for the command and control and employment of the aircraft? Will there be any significant reduction or increase in staff planning procedures regarding employment?

OPERATIONAL DEFINITIONS

Although not all-inclusive this list of definitions is considered critical in the analysis of this thesis.

CLOSE AIR SUPPORT: Air action against hostile targets which are in close proximity to friendly forces and which require detailed integration of each air mission with the fire and maneuver of those forces.⁶¹

The classic definition of CAS broadly encompasses any weapon system that delivers air-to-ground weapons in support of a ground commander's scheme of maneuver. More important, this unqualified definition technically includes attack helicopter operations, except that attack helicopters are by Army doctrine a maneuver force, not supporting fires.⁶² Further emphasis on this point came from the Army and Air Force Chiefs of Staffs. They stated jointly that "the Army and Air Force do not consider attack helicopters as CAS weapons."⁶³

There is not a satisfactory distance associated with the "close proximity" descriptor. What is widely accepted, and what this author will use, is the distance from the "danger-close" distance of the weapon being delivered out to the effective range of the ground forces weapons. On many occasions during the Vietnam War, CAS was called in on top of

friendly positions to prevent the position from being overrun, but that was certainly the exception.

JOINT AIR ATTACK TEAM (JAAT): A combination of attack helicopters and tactical fixed-wing aircraft, normally supported by field artillery or naval gunfire, operating together to attack surface targets.⁶⁴

ADVANCED JAAT (AJAAT): JAAT operations conducted with advanced helicopters providing LASER designation for PAVE PENNY equipped aircraft.⁶⁵

MANEUVER: The movement of forces supported by fire to achieve a position of advantage from which to destroy or threaten destruction of the enemy.⁶⁶

The concept of air maneuver has gained increased prominence within the Army community. It adds the third dimension - the air - to the ground commander's fight. Attack helicopters are considered the premier system for conducting air maneuver because of their speed, maneuverability, and lethality. When A-10's are employed with attack helicopters in a JAAT they too are operating as an air maneuver force. Although defined as a sub-mission of CAS, JAAT and AJAAT are actually offensive air maneuver, and this work will consider them as such.

CULMINATING POINT: That point in time or space at which the attacker's strength no longer significantly exceeds that of the defender.⁶⁷

ASSUMPTIONS

1. The existing Third World Threat will be present through the next decade, and will maintain a large tank/armor inventory.

2. The Air Force will retain proponency for the Close Air Support mission.

3. Contingency operations outside of the European theater will be the probable area of conflict through the next decade.

LIMITATIONS

1. This study will not include any classified material. Although classified material was researched, only those portions designated as unclassified will be included in this thesis.

2. Only Soviet-equipped units will be used to analyze combat capabilities to provide a worst-case scenario. It is recognized that Third World countries usually amass weapons from multiple sources, but those that purchase Soviet equipment also receive Soviet "assistance."

DELIMITATIONS

The reduction in forces and overall budgets for the Army and Air Force will not be considered as a factor in this thesis.

CHAPTER 1 ENDNOTES

1. U.S. Congress, Senate Bill 2884, National Defense Authorization Act for Fiscal Year 1991, 101st Congress, 2nd Session, 1990, Government Printing Office, 245-246.
2. Kent Roberts Greenfield, Army Ground Forces and the Air Ground Battle Team, Study No. 35. Historical Section, Army Ground Forces, 1948.
3. Jules E. Gonseth, "Tactical Air Support for Army Forces," Military Review, (July 1955), 7.
4. Alfred Goldberg and Donald Smith, Army-Air Force Relations: The Close Air Support Issue, (Special Report for the USAF Project Rand by the Rand Corporation, Oct 1971), p. vii.
5. *Ibid.*, 8.
6. *Ibid.*
7. *Ibid.*, 9.
8. *Ibid.*, 10.
9. Arthur T. Hadley, Straw Giant: America's Armed Forces, Triumphs and Failures, (New York: Avon Books 1986), 112-113.
10. David MacIsaac, "Voices from the Central Blue: The Air Power Theorists," in Makers of Modern Strategy from Machiavelli to the Nuclear Age, ed. Peter Paret, (Princeton, New Jersey: Princeton University Press, 1986) 643.
11. Goldberg, 13.
12. U.S. Department of Defense Directive Number 5160.22, Clarification of Roles and Missions of the Departments of the Army and the Air Force Regarding Use of Aircraft, (18 March 1957), 3-4.
13. Brooke Nihart, "Sixty Years of Unresolved Problems," Armed Forces Journal, (25 April 1970), 21.
14. *Ibid.*
15. U.S. Congress, House Committee on Armed Services, Close Air Support, 89th Congress, 2nd Session, 1966, 4862-4864.
16. Memorandum for Record, "Aircraft Inventory," Mr. Donaldson, March 1, 1965.

17. Thomas J. Monforte, Jr., "Contemporary CAS: Problems and Prospects," (Student Research Report, U.S. Army War College, Carlisle, Pa., 23 Mar 1987), 4.
18. Brooke Nihart, "Packard Panel Gets Off to Slow Start," Armed Forces Journal, (5 April 1971), 38.
19. Nihart, "Sixty Years," 24.
20. Ibid., 22.
21. Ibid., 25.
22. Goldberg, 38.
23. Ibid., 32.
24. Brooke Nihart, "Packard Review Group: Roles and Missions to Remain Untouched, Aircraft Systems to be Scrutinized," Armed Forces Journal, (19 April 1971), 20.
25. Goldberg, 49.
26. Monforte, 6.
27. Gen. John D. Ryan, "Quality is the Key to Force Effectiveness," Air Force Magazine and Space Digest, (May 1970), 45.
28. U.S. Congress, Senate Armed Services Committee, Hearings Before the Special Subcommittee on Close Air Support, 92nd Congress, 1st Session, 442.
29. Monforte, 7.
30. Tactical Air Command, Directorate of Concepts, Doctrine Policy and Studies, An Executive Brief on the Development of Close Air Support Doctrine, (Jan 1973), 49.
31. Monforte, 6.
32. "Squabbles Over the Warthog Successor," International Aviation, (Feb 1990), 151.
33. "USAF Aircraft-How Many, How Old?," Air Force Magazine (May 1990), 48.
34. Ibid.
35. Naval Institute Database, latest update 21 March 1989.

36. Stephen M. McClain, "Problems Associated With the Joint Air Attack Team," (Masters Thesis, U.S. Command and General Staff College, Ft Leavenworth, KS, 1982), 53.
37. Ibid., 57.
38. BG(Ret) John C. Bahnsen, "A New Army Air Corps or a Full Combat Arms Team Member," Armed Forces Journal International, (Oct 1986), 78.
39. William V. Backlund, "Can the Army Take Over CAS With Its Organic Aircraft," (Student Research Report, U.S. Air Force Air Command and Staff College, Maxwell AFB, AL., 1985), 24.
40. Max V. Terrien, "Close Air Support: Retrospective and Perspective-Is the Helicopter the Answer," (Masters Thesis, U.S. Army Command and General Staff College, Ft. Leavenworth, KS), 81.
41. Mark Ferrell and Scott Reynolds, "Apache Thunder," U.S. Army Aviation Digest, (May 1989), 3.
42. Scott A. Reynolds, A-10 Joint Air Attack Team with Improved Helicopters Tactics Development and Development, Report from the 57th Tactical Fighter Weapons Wing, Nellis Air Force Base, NV. SECRET, Data used was unclassified, July 1987, p. V.
43. Ibid., VI.
44. Richard G. Davis, The 31 Initiatives: A Study in Air Force-Army Cooperation, (Historical Study for the Office of Air Force History, Washington, D.C., 1987), 60.
45. Ibid., 153.
46. Dr. James A. Blackwell, "American Close Air Support - The Next Model," NATO's Sixteen Nations, (Vol 33 No. 8, Dec 88-Jan 89), 59.
47. Ibid.
48. David Fulghum, "Congress holds AF's favorite fighter hostage," Air Force Times, (27 November 1989), 26.
49. "Operational Test Plan for Evaluation of Close Air Support Alternative Aircraft," Report for the Office of the Secretary of Defense, (31 March 1989), i.
50. Squabbles, 151.

51. Fulghum, 26.
52. Ibid.
53. U.S. Department of Defense, Joint Chiefs of Staff Publication, JCS Pub 1-02, Dictionary of Military and Associated Terms, (U.S. Government Printing Office, Washington, D.C., 1 Dec 1989), 23.
54. Soviet Military Power: Prospects for Change, (Government Printing Office, Washington, D.C., 1989), 23.
55. Ibid., 34.
56. Lauren G. Mullendore, "The Future of the Joint Air Attack Team in the AirLand Battle," (Student Research Paper, U.S. Air Force Air War College, Maxwell AFB, AL, 1989), 5.
57. "Desert Shield", Air Force Times, (3 Sep 90), 13.
58. Tactical Aircraft Effectiveness and Survivability in CAS Anti-Armor Operations (TASVAL) Test Report Vol 1, Executive Report, (Director Defense Test and Evaluation, Office of the USDR&E, Washington, D.C., 1980) SECRET, 37. Data used was unclassified.
59. Stephan Budiansky, Carla Anne Robbins, Bruce B. Auster, and Peter Carey, "The Lessons of Desert Shield," U.S. News and World Report, (Sep 10, 1990), 37.
60. Ibid.
61. JCS Pub 1-02, 70.
62. U.S. Department of the Army, FM 1-100 Doctrinal Principles For Army Aviation in Combat Operations, (US Government Printing Office, Washington, D.C., February 1989), 1-13.
63. Carl E. Vuono and Larry D. Welch, Close Air Support Memorandum for the Chairman of the Joint Chiefs of Staff, (Washington, Department of the Army and Department of the Air Force, 11 October 1989).
64. U.S. Department of the Army, FM 90-21 JAAT - Joint Air Attack Team Operations, (U.S. Government Printing Office, Washington D.C., Sep 1990), p. G-3.
65. Ferrell, 3.
66. U.S. Department of the Army, FM 101-5-1 Operational Terms and Symbols, (U.S. Government Printing Office, Washington D.C., October 1985) p. 1-44.

67. U.S. Department of the Army, FM 100-5 Operations, (U.S. Government Printing Office, Washington D.C., May 1986), 109.

CHAPTER 2

THE MULTI-FACETED THREAT TO AJAAT OPERATIONS

INTRODUCTION

This chapter will address the current and projected threats the A-10 and Apache Team will face on the mid-intensity battlefield. This discussion is important because it will highlight the strengths and weaknesses of the threat systems, and in which countries these systems are deployed. The discussion will include the ability of the team to disrupt or defeat these threats.

THE THREAT

. . .the Soviet Union will continue to constitute the greatest military threat to United States' interests over the next fifteen years.

FM 100-5 (Draft, 1990)¹

The threat today in the low-to-mid intensity battle is formidable. Despite the reduction of Soviet presence in Eastern Europe, and the dismantling of an entire family of offensive nuclear weapons, the United States still considers the Soviet Union as the primary threat to America through the year 2000.

Soviet influence in the Third World continues to provide advanced weaponry to many unstable and unfriendly governments. Since 1980, the governments of Iran, Syria, Cuba, Iraq and Libya have displayed a willingness to act aggressively.

These countries are also major importers of Soviet weaponry and doctrine.

The array of Threat weapons that the A-10 and Apache team might encounter primarily includes a sophisticated air defense (AD) system, main battle tanks, and helicopter and close air support aircraft. The current threat doctrine is represented in the following passage.

Apart from Nuclear Weapons, attack helicopters pose the greatest threat to Soviet maneuver forces and any means available will be used to deter that threat. This includes 'supplementing the air defense effort with tank main guns, infantry fighting vehicle (IFV) cannons, machine guns, antitank guided missiles, lasers, and fighter helicopters.'²

Each of these threat systems will be discussed in terms of their total numbers, capabilities, and limitations beginning with the most prolific: AD systems.

AIR DEFENSE SYSTEMS

. . .one of the biggest hurdles attack helicopters will have to contend with is the air defense (AD) system protecting ground forces. The Soviets have put together as comprehensive an array of AD assets as can be found.³

Soviet AD is designed as a defense in depth. Their divisional AD assets cover an area that extends from 50 kilometers on their side of the Forward Edge of the Battle Area (FEBA) to 15 kilometers across the FEBA, and from a minimum altitude of less than 10 meters to a maximum of nearly 25,000 meters. The primary AD assets are radar guided surface-to-air missiles (SAM) that provide low, medium, and high-altitude

area protection, and antiaircraft machinegun systems for close-in point and area protection.

AD is normally managed as a cohesive system rather than separate entities operating individually. Every tactical command from the Front down to and including the Regiment has organic AD. Command and control for the entire system down to battalion level is exercised from the Front level. This obviously provides for unity of effort, but does not allow for initiative at the lower levels of command. Subordinate commanders have been faulted for inefficient planning for continuous AD coverage, especially during fast-paced operations.⁴

When the Soviets export their equipment, they also export their tactical doctrine. The Egyptians used this to their advantage during the October 1973 Arab-Israeli War. The Western world got its first glimpse of the effectiveness of the Soviet AD threat at the expense of the Israeli Air Force. Twenty-four hours into the war Israeli losses were so extensive that "all sorties were suspended while pilots rapidly consulted to consider by what means they might return to attack the enemy ground forces with a reasonable chance of survival."⁵

Figures 1, 2, and 3 show the typical AD array of a Soviet-type Motorized Rifle Division (MRD) as it would be arrayed for close-in battle.

With between 120 and 147 launchers, the SA-7 GRAIL is the most prolific AD weapon in the division. It is the first

AD weapon that the A-10 and Apache team will have to contend with. Figure 1 details the doctrinal location of the launchers in the front line battalions.

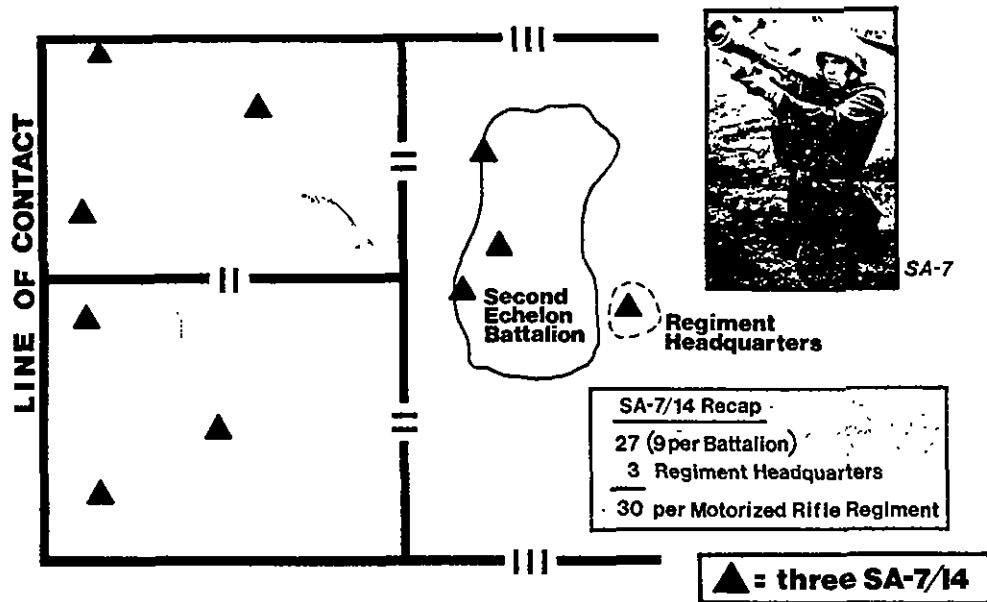

Figure 1
 SA-7/14 LOCATION IN A MRR⁶
 Source: Edward J. Bavaro, "Threat: Running the Gauntlet," U.S. Army Aviation Digest, (Oct 1986), 31, fig 1.

The SA-7 missile is used for close-in protection of command posts (CP's), and placed along expected air avenues of approach. It is a shoulder-fired, low altitude, infrared (IR) seeking missile with a maximum range of 3.5 kilometers, and a minimum attack altitude of 10 meters. The SA-7 is a "tail-chasing" missile only, and is similar in capabilities to

the U.S. Army's Redeye SAM. It is very susceptible to IR jammers, and is ineffective against current helicopter engine exhaust diffusers.

Nearly every country that procures weapons from the Soviet Union has the SA-7. Although used by Egypt in the 1973 war, the SA-7 was credited with only four Israeli kills, and was considered more of a nuisance than a viable threat.⁷

The SA-7 is being replaced in higher priority Soviet divisions with the SA-14 GREMLIN. The SA-14 is similar in capabilities to the U.S. Army's Stinger SAM, which does have a "head-on" attack capability. It is important to note that neither the SA-7 nor the SA-14 are found within the Soviet tank battalion. Unless the tank battalion is task organized into motorized rifle units, it will be without organic short-range AD coverage. This could render the unit very vulnerable to a surprise attack by an AJAAT.

The organic AD systems of motorized rifle regiments (MRR) and tank regiments (TR) are the SA-9 SAM/ZSU-23-4 antiaircraft gun (AAG) team. Figure 2 shows the doctrinal positioning of these systems within the regiments. There are 16 of each weapon system in each division.

The SA-9 GASKIN became operational in 1968. It is a mobile SAM launcher that fires an IR missile similar to the U.S. Army Chaparral. Target acquisition is through optical-mechanical sights. Once a target is selected the tactic is to salvo fire at least two missiles to increase the

probability of a hit while thwarting enemy infra-red counter-measure (IRCM) systems. Minimum attack altitude for the SA-9 is 20 meters.⁸

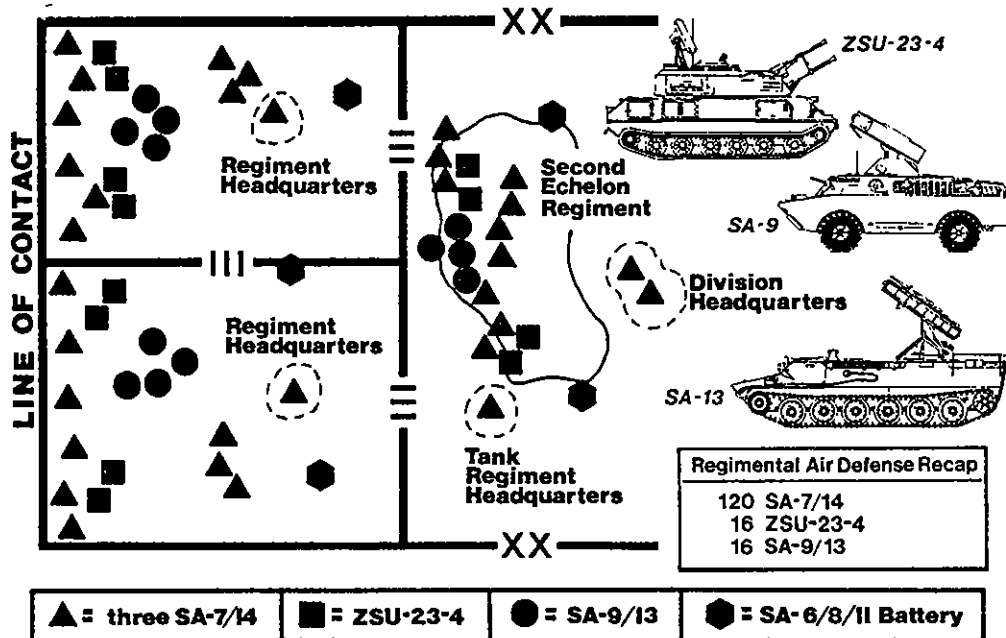

Figure 2
SA-9, SA-13, AND ZSU-23-4 EMPLOYMENT⁹
Source: Edward J. Bavaro, "Threat: Running the Gauntlet," U.S. Army Aviation Digest, (Oct 1986), 33, fig 2.

The SA-9 is being replaced with the more capable SA-13 GOPHER which entered service in 1977. The SA-13 also has a minimum attack altitude of 10 meters, and a minimum engagement range of 500 meters. The SA-13 is known to be in service in Angola, Cuba, Iraq, Jordan, Libya, and Syria.¹⁰

The ZSU-23-4 SHILKA has been one of the most successful AAG's produced. Its initial successes in the 1973 Arab-Israeli war sent tremors throughout the Western aviation community. It alone accounted for nearly 30% of the 105 reported Israeli aircraft lost in the 1973 war.¹¹ Since then,

it has been analyzed extensively. It has four 23mm cannons that are radar or optically aimed. The fire control radar is extremely susceptible to ground clutter against targets that are less than 200 feet in altitude. It can fire on the move, but its accuracy is diminished by 50% when it does. Additionally, the radar is very susceptible to electronic countermeasures (ECM), thereby necessitating visual acquisition and tracking. Visual tracking diminishes the maximum effective range to 2000 meters or less. Normal employment in the offense is to position the vehicles within 400 meters of the lead elements of the regiment.

Aside from the Warsaw Pact, this weapon is in service in nearly every Soviet-supplied Third World country, including Iran, Iraq, Libya, North Korea, and Cuba.¹² The ZSU-23-4 is being replaced with the ZSU-30-2 in the Soviet Army.

The ZSU-30-2 became operational in 1988, and is very similar to the West German Gepard. The ZSU-30-2 has four 30mm AAG's and four SA-19 launchers. It has not been exported as of yet.¹³

The ZSU-57-2 was the precursor to the ZSU-23-4. The ZSU-57-2 entered service in 1957. Its twin 57mm AAG's have limited capability in the ground-to-air mode, but has been found to be extremely capable in the ground-to-ground mode. The 57-2 is also tracked, but has no radar capability and must acquire and track targets visually. It has very limited protective armor, and is therefore very susceptible to artillery

fire and heavy caliber machine guns. It is in service widely within the Third World including, Iran, Iraq, North Korea, and Vietnam.

The Soviet division rear is protected by either SA-6, SA-8, or SA-11 systems. Figure 3 details the location of these systems in the rear area.

Although important to the overall AD umbrella, the SA-6, SA-8 GECKO, and the SA-11 GADFLY do not pose as great a threat to the Apache as the other systems already discussed. When operating at an altitude of less than 50 feet, the SA-8 is the only system that can engage the Apache. The SA-8 is a radar controlled missile with a minimum attack altitude of 10 meters, and a minimum range of 1600 meters. The SA-8 system is known to be in service in India, Iraq, Angola, Jordan, Libya, and Syria.¹⁴

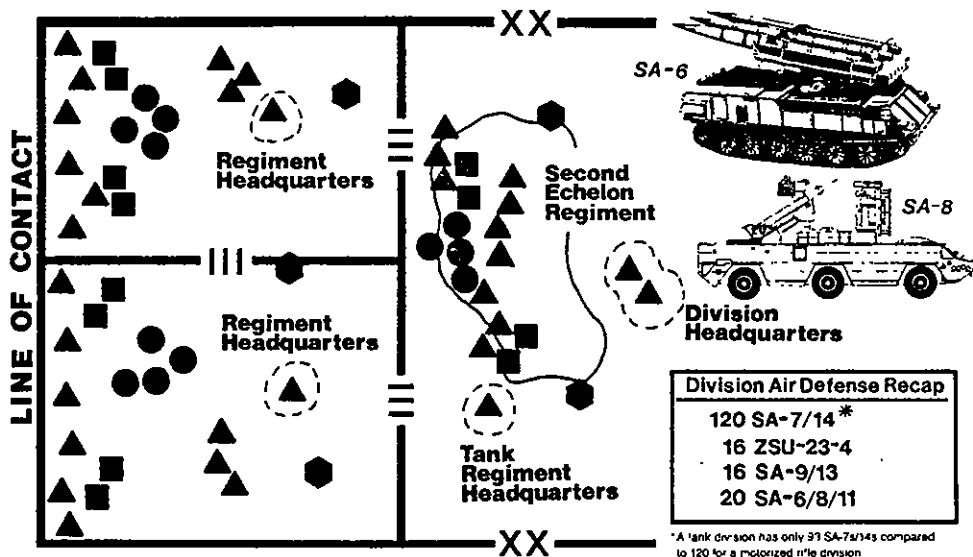

Figure 3

DIVISIONAL REAR AREA COVERAGE¹⁵

Source: Edward J. Bavaro, "Threat: Running the Gauntlet," U.S. Army Aviation Digest, (Oct 1986), 33, fig 3.

The SA-6 does represent a threat to the A-10. First introduced in 1967 and operational in 1970, it quickly gained world attention during the 1973 Arab-Israeli War. The SA-6 is a mobile system with the missiles on one vehicle, and the surveillance, acquisition and tracking radar on another vehicle. This separation represents a potential weakness of the system, especially during offensive maneuvers. If the radar vehicle is destroyed the system must rely on spottings from other radar sets, and is very unreliable in this mode.

The SA-6 was also introduced to the world during the 1973 war, and was used very effectively. During one day in battle over Syria, a Dutch United Nations observer reported that 30 Israeli aircraft were lost solely due to the SA-6.¹⁶ The effectiveness of the SA-6 caused the Israeli pilots to fly lower and lower attack altitudes to avoid the SA-6 causing them to fly into the envelope of the ZSU-23-4. The SA-6 is known to be in service in Libya, Iraq, Syria, Vietnam, and Cuba.¹⁷

The Israeli's flew over 8400 sorties against the Egyptians during the 20 days of the 1973 war. The 105 aircraft lost to AD systems represented a loss ratio of less than 0.75%. Despite their very low loss ratio, the Egyptian AD umbrella succeeded in dramatically degrading the Israeli sortie effectiveness. Many Israeli aircraft never reached their target or dropped their ordnance inaccurately because of the AD threat.¹⁸ The degraded effectiveness created the requirement for the large number of sorties.

The Threat has developed and produced an impressive array of AD systems. More often than not the AJAAT will be exposed to the older, less sophisticated systems in the Third World than the front line Soviet equipment. Defeating or negating the systems effectiveness will be discussed in detail later in this chapter. Figure 4 lists the composite threat AD system capabilities.

	MIN ALT (M)	MAX ALT (M)	MIN RNG (KM)	MAX RNG (KM)	GUIDANCE
SA-2 GUIDELINE	100	18,000	5	50	RDR CMD
SA-3 GOA	50	15,250	6	22	RDR CMD; SAH
SA-4 GANEF	1100	24,000	9.3	50	RDR CMD; SAH
SA-6 GAINFUL	100	12,000	3.7	30/60	RDR CMD; SAH
SA-7 GRAIL	45	1,500	.6	3.6	IR HOMING
SA-8 GECKO	10	13,000	1.6	12	RDR/OPT; SARH
SA-9 GASKIN	14	6000	.8	6	IR HOMING
SA-10 GRUMBLE	10	30,500	9.5	100	SAR; ACTIVE
SA-11 GADFLY	30	14,000	3	28	RDR CMD; SARH
SA-12 GLADIATOR	900	30,000	5	80	SARH
SA-13 GOPHER	10	10,000	.5	10	IR HOMING
SA-14 GREMLIN	10	5,500	.6	6	IR HOMING
ZSU-23-4 SHILKA	0	1000	0	2.5	RDR/OPTICAL
ZSU-57-2	0	800	0	4	OPTICAL

RDR CMD - RADAR COMMAND
SAH- SEMI-ACTIVE HOMING

SARH- SEMI-ACTIVE RADAR HOMING
IR- INFRA RED

Figure 4
THREAT AIR DEFENSE SYSTEMS CAPABILITIES¹⁹

ARMOR VEHICLES

The Tank. . . is an offensive weapon. Any defensive system involves the dispersal of forces over a wide territory, leaving them strong in some places and weak in others. And it is where they are weak that the tanks will appear in enormous concentrations.

Viktor Suvorov, Inside the Soviet Army²⁰

The most underrated and overlooked AD threat, particularly to attack helicopters, is the main gun of the thousands of enemy tanks. The extremely high muzzle velocity of the main gun projectile, the high sustained rate-of-fire of the tank, and the impressive maximum range of the weapon make the tank main gun an ominous AD weapon. The two admitted Israeli helicopter losses in the 1982 invasion of Lebanon, were attributed to tank main guns.²¹

The Soviet have continued to emphasize this tactic with improvements to their new tank systems. The T-80 and T-64B main battle tanks (MBT's) are now outfitted with the AT-8 SONGSTER antitank missile. The AT-8 radio-guided missile, similar to the American Shillelagh missile, is fired through the main gun tube out to an estimated range of 4000 meters,²² and was designed for use against vehicles and helicopters. This capability severely reduces the standoff advantage that helicopters presently possess over current armor. The T-80 is thought to be possibly fielded in Syria, while the T-64 family of tanks has never been exported outside the Soviet Union.²³

Soviet tactics have also changed in regard to attacking helicopters. Whenever hostile helicopters are discovered

the armor column stops momentarily and engages the threat. If the threat is not immediately defeated, the armor advances rapidly toward the threat firing their main gun and organic machineguns.²⁴ This tactic is designed to dislodge the helicopter unit. It is a very effective tactic, but exposes the threat column to be attacked effectively by the AJAAT. This will be discussed in detail in later chapters.

COUNTER-AIR THREAT

The counter-air threat is two-pronged. There is a threat from fixed-wing jet aircraft conducting CAS or BAI (battlefield air interdiction) in support of the enemy ground maneuver. Much more dangerous is the threat from enemy helicopters conducting attack and CAS missions deep, close, or in their own rear areas.

Helicopter Threat

. . .helicopters are practically invulnerable to ground anti-aircraft weapons. . .therefore, it has become vital to get a weapon which could compete with the helicopter. . .Logic and historical experience suggest that such a weapon is the helicopter itself.²⁵

Colonel Belov, Soviet Army, 1979

Major General Belov, the leading helicopter theoretician of the Soviet Union, is credited with being the spark that ignited Soviet helicopter air-to-air doctrine. The realization of the capabilities and lethality of the Western attack helicopters is best summed in the following statement by Belov.

. . .helicopters have proved most effective as versatile fire system highly superior to other combat vehicles as regards observation, maneuverability and choice of time and place of delivering a blow.²⁶

The Mi-24A HIND, the Soviet Union's first attack helicopter, became operational in 1974. Since that time it has undergone extensive improvements and modifications to its current "F"-model version.

The Hind helicopter is classically used as an organic CAS aircraft in the Soviet division. Each division has 6 organic Hinds in an attack company that is in direct support of the ground fight. At the Army level, there is an attack regiment with 40 Hinds assigned.²⁷ The Hind has the capability to carry a variety of ordnance including 57mm rockets, the AT-2 SWATTER, or AT-6 SPIRAL antitank missiles, and either a 12.7mm, 23mm gatling gun, or a 30mm multi-barrel cannon. The aircraft is heavily armored, and can carry troops internally. Figure 5 shows the doctrinal employment of the Hind during Soviet offensive operations.

It is important to note that one of the Hind's primary missions is counter-air operations against the AJAAT. This directly corresponds to the philosophy the Belov preaches, and represents a significant air-to-air threat that cannot be overlooked. How the AJAAT performs its mission and handles this threat will be discussed in chapter 3.

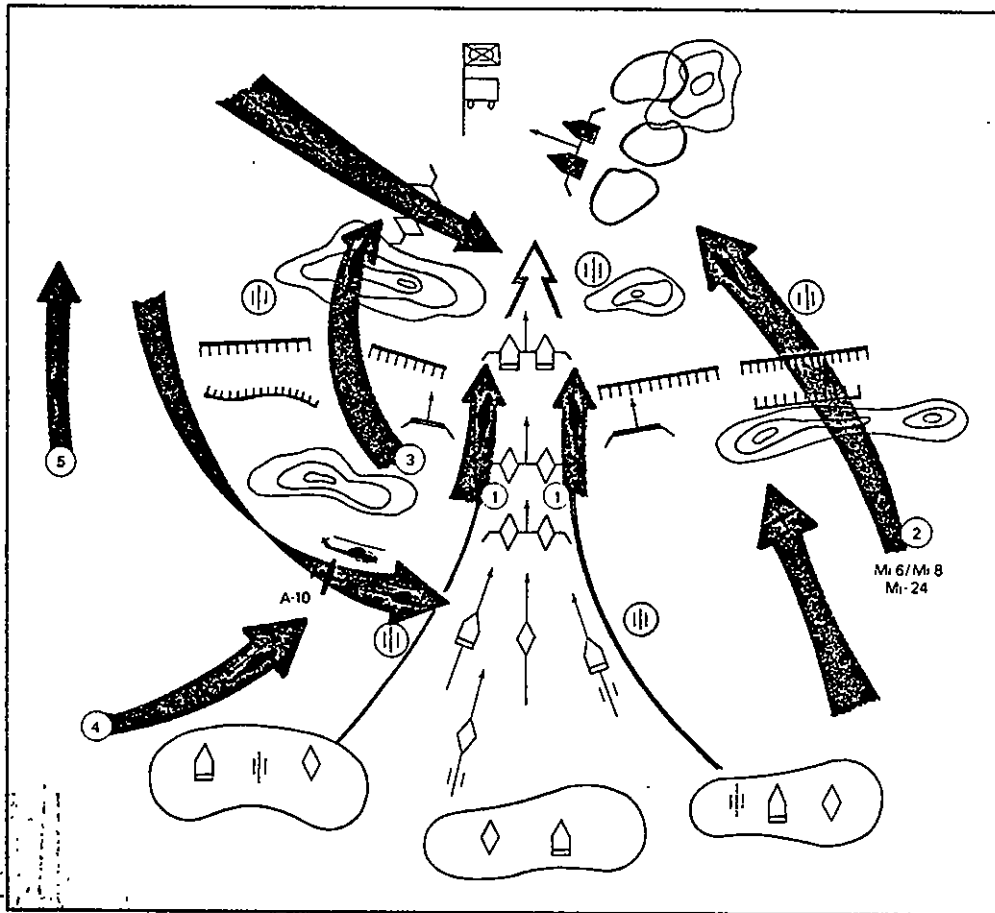

- 1 Support the main attack, penetration, and exploitation in a primary ground attack/close air support role using guns, rockets, bombs, and ATGM.
- 2 Support an air assault/airmobile operation in an escort role and provide fire support and security against ground/army aviation counter attack.
- 3 Support the main attack by destroying enemy reserve armor force in a primary anti-tank role.
- 4 Support the main attack by protecting its follow on echelons from attempted deep battle operations by Joint Air Attack Teams
- 5 Support the main attack by conducting supporting attacks in adjacent sectors either autonomously or in conjunction with diversionary ground attacks.

Figure 5
MI-24 TACTICAL MISSIONS²⁸
 Source: Defense Intelligence Agency, Military Implications of the MI-24 HIND E Attack Helicopter, (7 Mar 1983), 49, Fig 19.

Figure 6 shows the Hind conducting doctrinal CAS attacks. Its relatively high attack altitude makes the Hind vulnerable to not only friendly AD systems, but also friendly armor systems, and most importantly, the AJAAT.

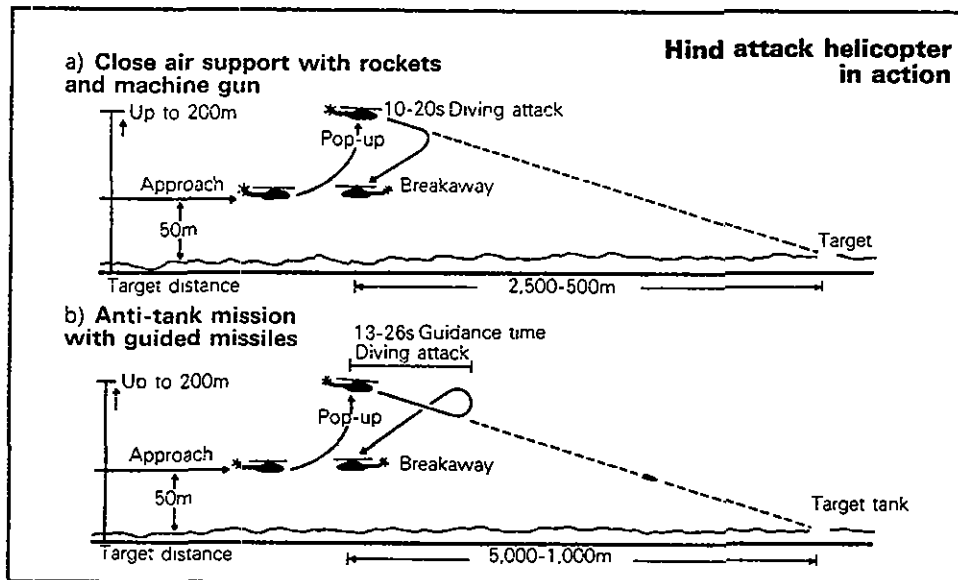

Figure 6

HIND ATTACK PROFILE²⁹

Source: Manfred Niesters, "Soviet Helicopter Doctrine," International Defense Review, (10/87), 1324.

The Hind, or its export version the MI-25, is in service in Afghanistan, Angola, Cuba, India, Iraq, Libya, Nicaragua, North Korea, Vietnam, and Yemen.³⁰

The newest addition to the Soviet attack helicopter arsenal is the MI-28 Havoc. The mere existence of the Havoc prompted the cancellation of the SGT York AD system. The Havoc was speculated to have an effective range out to 6 kilometers (km), and the SGT York was to be effective to only 4 kms.³¹ The loss of the SGT York again left the U.S. Army with only 1200 meter Vulcan AD gun coverage and 3 kilometer Stinger missile coverage in the Army heavy division.

Similar in design to the Apache, the Havoc is also primarily an antitank helicopter. It is armed with a modified AT-6 SPIRAL antitank missiles equipped with a millimeter wave seeker, 57mm rockets, a modified SA-14 GREMLIN missile for air-to-air combat, and a 30mm cannon in a chin turret. The

Havoc does not currently possess the adverse-weather, day-night capabilities of the Apache, nor is it as maneuverable. It is however, a very formidable threat to the ground commander as well as the A-10 and Apache in the air-to-air arena. It cannot be overlooked. The Havoc is projected to become operational in 1991, with the projected organization being unknown. Projected exportation of the aircraft is likewise not known.³²

The threat that Belov believed was to be the essence of anti-helicopter combat is nearing operational status. The HOKUM will be the first counter-helicopter helicopter ever fielded. The estimated performance capabilities of this counter-rotating helicopter includes a maximum level airspeed of 190 knots, and a combat radius of 250kms.³³ Not currently in production, the aim of the aircraft is clearly to attack the strength of Western antitank forces, the attack helicopter, and close the "gap" in the Soviet AD umbrella. The speed, maneuverability, and lethality of the HOKUM also make it a threat to the A-10. Impending deployment, and possible sale to Third World countries, underscores the need to have an effective team that can provide mutual anti-helicopter support while conducting its mission. The A-10 can provide the Apache with offensive air-to-air capability to defeat the HOKUM, while the Apache can provide early warning to the A-10.

Fixed-Wing Threat

The Soviet Air Force is extremely large, and continuously improving its capabilities. Still the threat from fixed-wing aviation is relatively small. The primary threat to the AJAAT will be from those aircraft working near or with their own helicopters. This threat will primarily be the SU-25 FROGFOOT.

The Frogfoot is a very close cousin in design to the U.S. Air Force A-9. (The A-9 was the loser to the A-10 in the A-X CAS competition.) The Frogfoot became operational in 1984, and was immediately deployed to Afghanistan. Reports from Afghanistan indicate that the aircraft was used to develop techniques for employment with the MI-24 Hinds, an attempt at Russo-style JAAT perhaps.³⁴ It is assigned to Frontal Aviation, and deployed in the Aviation Assault Regiment. Each Regiment consists of four Aviation Assault Squadrons with each squadron assigned 12 Frogfoots.³⁵

The aircraft is capable of carrying large ordnance loads, including air-to-air missiles, on external wing points and has a twin-barrelled 30mm cannon internally mounted in the fuselage. The maximum level flight airspeed at sea level is .8 Mach, significantly faster than the A-10, but with a very poor on-station time when compared to the A-10. Known users outside of the Soviet Union include the North Koreans and the Iraqis.³⁶

The Frogfoot is an air-to-air threat to the AJAAT. Tactics, techniques and procedures (TTP) for combating this and other air threats are needed. This TTP must be for the team and not individual assets to ensure the greatest tactical success.

SUMMARY

The Soviets have developed and deployed a very formidable AD threat. The AD umbrella is based upon depth throughout the battlefield, and is designed against all threat aircraft. Despite the attempt to eliminate all air maneuver corridors, gaps still exist in their AD umbrella.

Mr. Edward Bavaro, an award winning author employed by the Threat Branch of the Army Aviation School, Fort Rucker, Alabama, describes an "operational window"³⁷ existing in the Soviet AD umbrella. It is in this "window" that air maneuver forces can operate with relative safety while attacking ground forces. He defines this "operational window" as the area not coverable by the Soviet AD systems. This area, shown in Figure 7, is primarily due to the limited range of the AAG systems and the minimum attack altitudes of the AD missile systems. This "window" increases in altitude and width the farther from the FEBA the helicopter and aircraft operates.

Soviet attempts to close this operational window are focused on using counter-air tactics to attack and disrupt friendly air maneuver. Current Western doctrine is directed

at maintaining that window open with defensive counter-air maneuver.

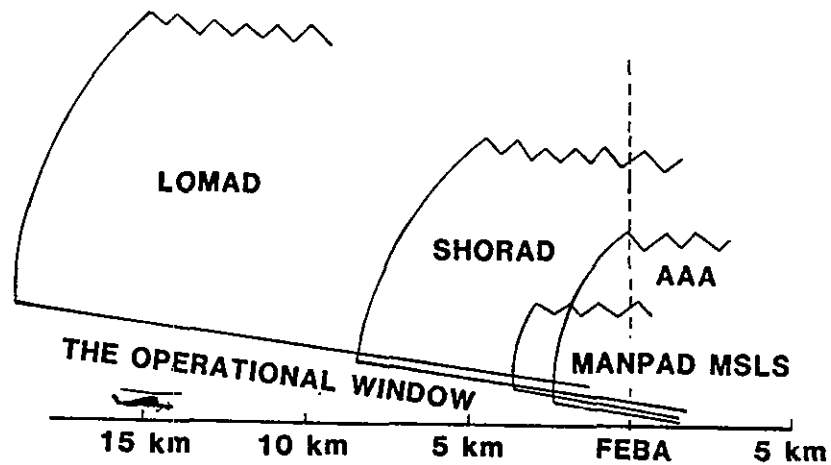

Figure 7
OPERATIONAL WINDOW³⁸

Source: Edward J. Bavaro, "Threat: Closing the Window,"
"U.S. Army Aviation Digest, (Jan 1986), 18.

Until the deployment of the Havoc and Hokum into the Third World, the counter-air threat to the A-10 and Apache will be limited to the Hind and Frogfoot. This threat can be dealt with by the AJAAT, and should not hinder the team from conducting their mission.

The ability to conduct missions against the Threat AD systems is due in large part to the aircraft survivability equipment (ASE). ASE includes radar-warning receivers, radar jammers, IR jammers, chaff dispensers, and flares. All are designed to defeat a specific type of AD threat. The proper use of this equipment, coupled with proper tactical employment procedures will provide adequate assurance of operational success for the A-10 and Apache team against the AD threat in the mid intensity conflict. Current AJAAT systems capabilities and limitations will be discussed in detail in Chapter 3.

CHAPTER 2 ENDNOTES

1. U.S. Department of the Army, FM 100-5 (Draft), U.S. Command and General Staff College, (1990).
2. Edward J. Bavaro, "Threat: Running the Gauntlet," U.S. Army Aviation Digest, (Oct 1986), 34.
3. Ibid., 30.
4. U.S. Department of the Army, FM 100-2-3 (Draft), (18 June 1990), p. 10-24.
5. Max V. Terrien, "Close Air Support: Retrospective and Perspective-Is the Helicopter the Answer?", (Masters Thesis, U.S. Army Command and Staff College, Ft. Leavenworth, Ks), 57.
6. Bavaro, Gauntlet, 31.
7. U.S. Army Training and Doctrine Command, Soviet Air Defense in the ME, (Report prepared by Assistant Chief of Staff for Intelligence), 2.
8. Bavaro, Gauntlet, 33.
9. Jane's Land-Based Air Defense 1989-90, second edition, (edited by Tony Cullen and Christopher F. Foss), 133-134.
10. Ibid., 138-139.
11. Ibid., 86.
12. Ibid., 86-89.
13. Ibid., 84-86.
14. Jane's, Land-Based, 131-133.
15. Bavaro, Gauntlet, 33.
16. "SA-6- Arab Ace in the 20-Day War," International Defense Review, edited by R.D.M. Furlong, (Vol 6, No 6, December 1973), 779.
17. Jane's, Land-Based, 127-131.
18. Anthony H. Cordesman and Abraham R. Wagner, The Lessons of Modern War, Volume 1: The Arab-Israeli Conflicts, 1973-1989, (Boulder, CO.: Westview Press, 1990) 73-82.

19. Christopher Chant, Air Defense Systems and Weapons, World AAA and SAM Systems, (Washington: Brassey's Defense Publishers, 1989), pp. 58-79, 196-200.
20. Bavaro, Gauntlet, 30.
21. Laura L. Tewes, "The Israeli Air Force and the 1982 Lebanon War," U.S. Army Aviation Digest, (July/Aug 1990), 64-65.
22. Jane's Armour and Artillery 1989-90, 10th edition, (edited by Christopher F. Foss), 81.
23. Ibid., 82.
24. Edward J. Bavaro, "Threat: Closing the Window," U.S. Army Aviation Digest, (Jan 1986), 12.
25. Edward J. Bavaro, "Soviet Helicopter Air-to-Air," U.S. Army Aviation Digest, (Mar 1988), 6.
26. Colonel M. Belov,, "How to Fight Helicopters," U.S. Army Aviation Digest, (Oct 1981), 20.
27. Manfred Niesters, "Soviet Helicopter Doctrine," International Defense Review, (No. 10/1987, Oct 1987), 1324.
28. Defense Intelligence Agency, Military Implications of the Mi-24 Hind E Attack Helicopter, (Technical Report, 7 Mar 1983, SECRET, Data used was unclassified), 49.
29. Niesters, 1322.
30. Jane's Land-Based, 269-270.
31. Ibid., 272.
32. Ibid.
33. Niesters, 1325.
34. Jane's Land-Based, 257.
35. Steven S. Zaloga, "The SU-25 Frogfoot," Jane's Soviet Intelligence Review, (Oct 1989), 461.
36. Jane's, Land-Based, 257.
37. Bavaro, Window, p. 10.
38. Ibid.

CHAPTER 3
THE ADVANCED JOINT AIR ATTACK TEAM

INTRODUCTION

Joint Air Attack Team (JAAT) includes Army attack helicopters, Air Force CAS aircraft, and supporting fires from Army or Marine artillery, or naval gunfire working together to defeat enemy ground forces and equipment. This chapter will discuss the two key elements that comprise the "Advanced" Joint Air Attack Team (AJAAT): the AH-64 and the A-10. The discussion will focus on AH-64 and A-10 strengths and weaknesses, their support requirements, and current force structure.

THE AH-64A APACHE

The AH-64A Apache was "technically" born on 10 August 1972 when the Army formally introduced the Advanced Attack Helicopter (AAH) program.¹ The first Apache unit was fielded at Fort Hood, Texas in April 1986, and as of December 1990, the Army had fielded 21 Apache battalions throughout the world. Total planned fielding is for 41 battalions to be completed by August 1995.² Aside from the United States, the Israeli Air Force and the United Kingdom have shown an interest in the Apache. Figure 8 shows the current locations around the world that have Apache units assigned.

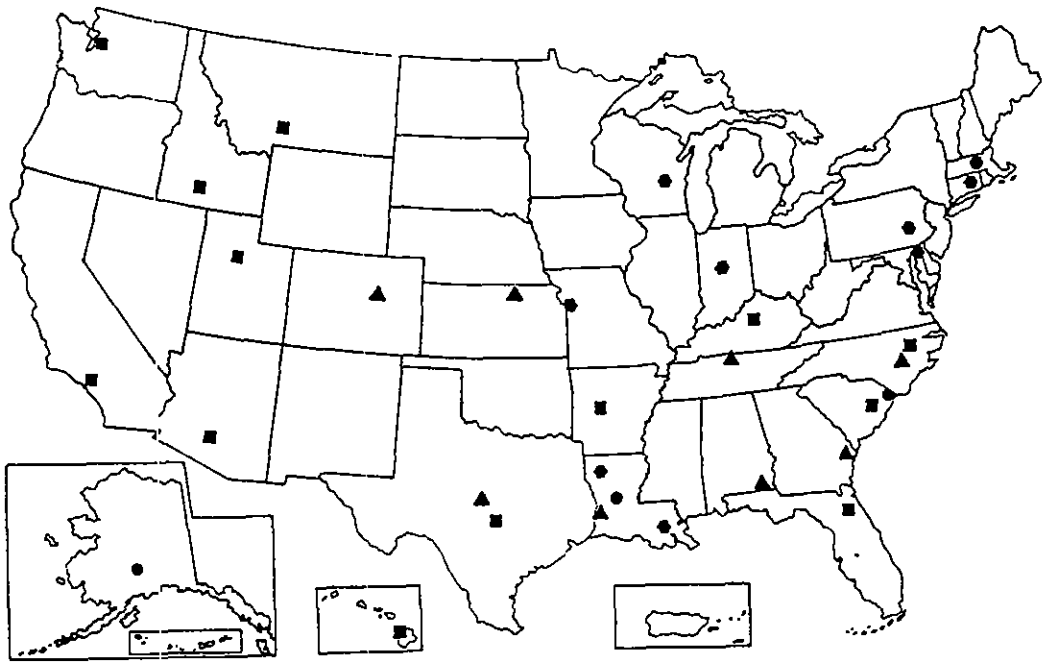

- ▲ -- ACTIVE ARMY UNITS
- -- ARMY RESERVE/
NATIONAL GUARD UNITS
- -- ACTIVE AIR FORCE UNITS
- ⬢ -- AIR FORCE RESERVE/
NATIONAL GUARD UNITS



Figure 8
A-10 AND APACHE UNIT LOCATIONS³

ORGANIZATION

The basic organization for the Apache is the Attack Helicopter Battalion shown in figure 9. The battalion has 18 Apache helicopters distributed within its three attack companies. The battalion is also equipped with 13 OH-58C Aeroscout aircraft, and 3 UH-60A or L-model Blackhawk utility aircraft.

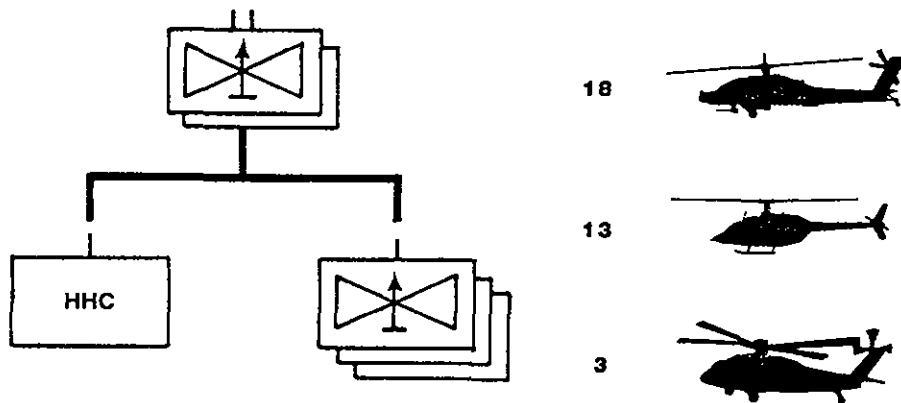

Figure 9
THE ATTACK HELICOPTER BATTALION⁴
(APACHE EQUIPPED)

Source: U.S. Army, FM 1-111, Aviation Brigade,
(Aug 1986), 1-4, Fig 1-43.

The Aeroscout aircraft are the older, less capable predecessor of the OH-58D. These aircraft are the "C" version, and its primary mission is to provide the company commander with a command-and-control platform from which he can fight his company. The lack of any optical systems, weapons, or the same communications capabilities as the Apache

has led commanders to shift their choice of command-and-control aircraft more and more to the Apache itself. This is especially in light of the demonstrated night deep-attack mission the Apache has become noted for.

The three UH-60 Blackhawk utility helicopters are used in a number of roles. These roles include command-and-control platform for the battalion commander and operations officer, forward arming and refueling point (FARP) support and replenishment operations, and maintenance recovery operations by the Service Company.

Funding constraints by Congress diminished the total Apache purchase contract to 807. To ensure that all the battalions planned were fielded the decision was made that the final seventeen Apache battalions fielded will have only 15 Apaches per battalion instead of the original 18.⁵

The mission of the attack battalion is "to destroy massed enemy forces with aerial firepower, mobility, and shock effect."⁶ The Attack Battalion is found at the division and corps level. The Aviation Brigade in the Heavy Division has one or two organic attack helicopter battalions depending on the division's location and mission. Each heavy corps has a Corps Aviation Brigade (CAB). The CAB has one active and one reserve component attack helicopter regiment. Figure 10 depicts the current CAB structure. The active attack helicopter regiment has up to four attack helicopter battalions for a total of 72 Apaches.

The CAB is the primary deep maneuver asset for the corps commander. The corps commander can simultaneously provide attack helicopter assets to his divisions and still retain sufficient assets to conduct his deep battle, or any of the multitude of possible contingency plans. The CAB does not have a dedicated direct support (DS) or general support (GS) maintenance organization within the brigade. The corps support command (COSCOM) is responsible for providing support to the CAB through its aviation intermediate maintenance (AVIM) units.

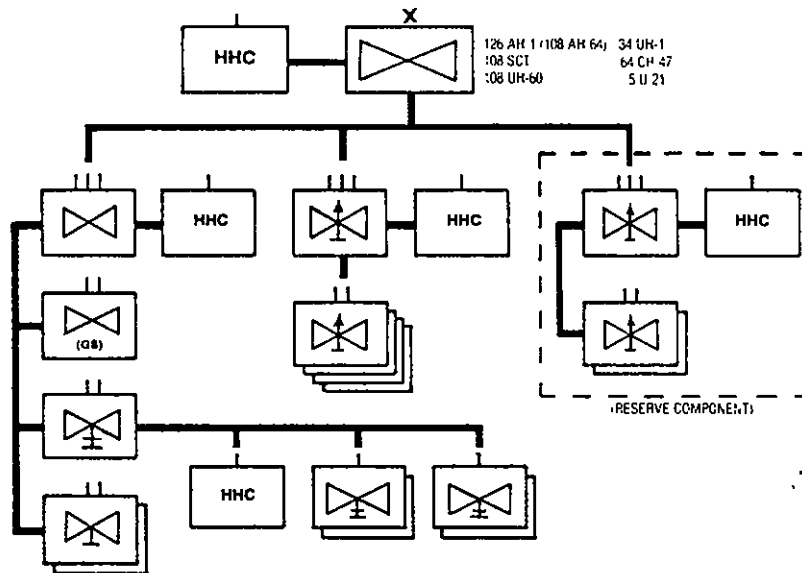

Figure 10
 CORPS AVIATION BRIGADE⁷
 Source: U.S. Army, FM 1-111 Aviation Brigade, (Aug 1986),
 B-1, Fig. B-1.

STRENGTHS

According to Mr. Norman B. Hirsh, Executive Vice President for McDonnell Douglas, the AH-64 Apache is the most survivable and advanced attack helicopter in the world.⁸ It possesses an impressive adverse-weather, day and night capability that is unknown in any other helicopter system. Pre-eminent strengths are its built-in survivability, its aircraft survivability equipment (ASE) package, and its weapons systems.

Survivability

"The Apache is invulnerable to single small arms hits, and nearly invulnerable to 23 millimeter projectiles."⁹ This capability is the result of a blend of redundant mechanical and electrical systems, and special materials selected to provide ballistic protection for every dynamic and critical component in the aircraft.

The helicopter is powered by two General Electric turboshaft engines, either of which is powerful enough to provide the Apache with sufficient power for continued flight with only one of two engines operating. Single-engine capability allows the Apache pilot to choose whether or not to continue his mission after losing an engine, whereas his predecessor in the single-engine AH-1 Cobra could not.

The ASE package includes a passive radar warning receiver tuned to known Threat radar transmitters, an infrared

(IR) countermeasures system capable of defeating known Threat IR seekers, a radar jammer set, and a chaff and flare dispenser. All systems are used in concert to thwart Threat air defense systems and allow the Apache to complete its mission and survive.

Finally, the Apache is extremely maneuverable. Its flight envelope allows maneuver between $-.5G$'s and $+3.5G$'s. This provides the pilot with near-aerobatic capabilities which are essential when operating in an air-to-air threat arena, or nap-of-the-Earth (NOE) environment. This, coupled with the Apache's forward, lateral, and rearward speed capability, enhances overall aircraft survivability on the mid to high intensity battlefield for which the Apache was designed to fight on.

Weapon Systems

The Apache has a complement of point and area weapon systems. The Hellfire anti-tank laser-guided missile is the primary weapon system carried on the Apache. The Apache can carry up to sixteen Hellfire missiles distributed equally on its four wing stations. Once launched, the Hellfire missile attacks targets by homing-in on reflected laser energy. Laser designation can be initiated by the Apache that fires that missile, another Apache tuned to the same laser frequency, or a remote laser designator. Remote designators are usually OH-58D aircraft working in concert with the Apache. The

ground/vehicular laser locator (G/VLLD) designators used by the Field Artillery for "Copperhead" target designation are also capable of providing laser targeting for the Apache's Hellfire. The Hellfire missile has a range of eight kilometers, and can defeat any known enemy armor.

Area suppression is provided by the 2.75 inch folding fin aerial rocket (FFAR) system. Rockets are carried in 18-shot rocket pods mounted on the wing pylons. Up to four rocket pods can be carried giving the Apache a capacity for 76 rockets. Although designated as an area fire system, the rocket system has unique capabilities. LTC(P) Robert V. Mitchell, former commander of the 3rd Squadron, 6th Cavalry Brigade (one of the original Apache attack battalions fielded), explained that the 2.75 inch FFAR with its new launch motor and selection of warheads, when coupled with the Apache fire control computer, is accurate enough to attack point targets such as personnel carriers.¹⁰ This gives the Apache commander the capability to provide his own fire support when conducting operations beyond the range of friendly artillery, as in a deep-AJAAT.

Wing stores selection is dependent upon the mission. The four hard-points allow for flexibility. A normal mission load might include two 18-shot rocket pods, and two 4-missile Hellfire missile racks. This gives the pilot the capability to carry thirty-six rockets and eight Hellfire missiles.

The 30 millimeter chain-gun mounted under the nose of the aircraft is an area suppression weapon. The gun fires at a rate of 600 to 650 rounds per minute, and the system carries a maximum of 1200 rounds in the magazine.

The pilot night vision system (PNVS) and target acquisition and designation system (TADS), referred to as the TADS/PNVS system, gives the Apache its unprecedented day-night capability. The TADS has a 126-power day television for target acquisition while the PNVS has a 36-power forward-looking-infrared-radar (FLIR) that enables the Apache pilot to fly and fight at night.

The Apache is a rapid deployment asset. It is air transportable in the Air Force C-141B, the C-17, and the C-5A/B, which can carry up to six Apaches. When required the Apache can self-deploy up to an unrefueled range of 1000 nautical miles. This is accomplished using four auxiliary fuel tanks which enable the Apache to self-deploy to Europe or any other theater in the world. The weapons stores would have to be delivered by other means to the theater of operations, and would presumably be transported in the first support aircraft deployed.

Avionics

The Apache avionics suite is extremely versatile. Installed communications includes a HAVE-QUICK UHF radio, two VHF-FM radios, and a Doppler navigation system. The

HAVE-QU CK UHF uses frequency-hopping to prevent jamming and or enemy interception. The radio is compatible with the radio installed in the A-10 and other Air Force aircraft. The VHF-FM radios are used for internal and external communications. Of the two radios, one is securable using the standard Army Vinson-type security equipment. This provides continuous near-secure communications with the team and continuous secure communications with the ground commander.

The Doppler navigation system enables the Apache pilot to navigate almost anywhere in the world. The pilot preselects his destination and a flight route, enters the data into the Doppler computer, and then follows the computer generated course. The system does have some difficulty over water, but otherwise is reliable and accurate, and is essential during long range deployments.

SUSTAINMENT

The Apache battalion is designed to operate as an independent maneuver force. Therefore, each attack company has its own organic maintenance personnel who conduct first level maintenance aimed at early fault detection and preparation for daily operation. The battalion has a Service Company that conducts second-level and some third-level maintenance including periodic phase inspections. The Apache maintenance program is based on hours flown. A complete inspection cycle is

1000 hours, but that time is subdivided into four 250-hour increments.¹¹ Each 250-hour cycle inspects different components of the aircraft so that by the end of the 1000-hour cycle all parts of the aircraft have been inspected. The cycle then begins anew for another 1000 hours.

The Apache has been the center of controversy about its sustainability. A September 1990 General Accounting Office (GAO) study concluded, "the 11 combat battalions [AHB] in the field at the time of the GAO's review began achieved a 50-percent fully-mission-capable [FMC] rate from January 1989 through April 1990."¹² This was not totally accurate. Senator John McCain, in testimony before Congress explained the inaccuracy. The low FMC did not take into account the fact that two major Apache installations, Fort Hood, Texas, and South Carolina, were still recovering from major storm damage. The aircraft in those units that were damaged or destroyed were counted in the GAO study.¹³ This would significantly decrease a unit's FMC rate, and probably accounts for that low rate.

Recent examples of the Apache's sustainability include Operation JUST CAUSE and the 1990 REFORGER (Return of Forces to Germany) exercise. During Operation JUST CAUSE, the operational ready (OR) rate was over 80%. Several aircraft received battle damage, and all were returned to the battle within 36 hours. The REFORGER exercise used six Apache battalions, the largest Apache force used to-date, and flew more

than 2600-hours, and maintained an 80% OR rate.¹⁴ McCain's testimony certainly disputes GAO's premise that the Apache is not sustainable.

LIMITATIONS/RESTRICTIONS

Technology

Perhaps the most visible limitation of the Apache has been the maintenance of its advanced-technology components. The aircraft was designed and built around some first and second-generation state-of-the-art systems, in particular the TADS/PNVS. The maintenance requirements are significant. As a result the Apache has been embroiled in media-hype over its availability. On several occasions the aircraft was grounded for long periods after faulty parts were discovered. This is partly the reason for a major Apache unit not being deployed to Saudi Arabia in support of Operation DESERT SHIELD.¹⁵ In each case the problems were resolved, but they did nothing for the aircraft's credibility. Many of the systemic maintenance issues that initially plagued the Apache have been resolved. The training that units receive prior to fielding the Apache reinforces the proper maintenance procedures. All Apache battalions undergo a four-month one-station fielding at Fort Hood, Texas. Units conduct extensive individual, team, and combined arms training. The unit is required to successfully pass an external evaluation (EXTEV) before they return to their home station. This ensures that units returning to their home-station are a fully-equipped, combat-ready unit.

An extension of the technology difficulty is the Hellfire missile. The Hellfire is the most lethal anti-tank missile currently deployed in the West; however, its top-down attack technique has presented units with employment challenges.

The Hellfire has two launch modes: lock-on-before-launch (LOBL), or lock-on-after-launch (LOAL). In LOBL the Hellfire receives reflected laser energy before launch, normally through self-designation, and has a maximum Hellfire range of 5 kms. In LOAL, the Hellfire receives laser targeting from another source, and this gives the Apache its maximum Hellfire range of 8 kms. When launched, the missile leaves the missile rail and automatically climbs to a preset search altitude depending on the launch mode. For LOBL, that altitude is approximately 500 feet. In the LOAL mode that altitude ranges from 500 feet to as high as 2300 feet at the maximum range of the missile.¹⁶

This search altitude presents a significant problem during limited-visibility weather conditions. The laser tracker in the Hellfire has difficulty "seeing" through moisture (clouds). If the missile does not receive sufficient laser energy to lock-on to the target, the missile could be lost. Reduced ceilings force the Apache crew to reduce their standoff distance to increase the probability of hitting the target. Logically, reducing the standoff distance increases

the probability of being engaged; therefore, decreasing the Apache's survivability.

The Apache was designed to fly and fight at night, yet it lacks the ability to see one of its most lethal threats: wires. This is particularly a hazard when operating and flying with the FLIR in the narrow field-of-view (FOV) mode.

The narrow FOV limits the pilot's peripheral view, and the pilot cannot easily identify telephone poles or power poles which are his instant indicators of wire hazards. The pilot's (back seat station) FOV is +/-15 degrees laterally by +/-20 degrees vertically (or expressed as 30X40), and is fixed at 1:1 resolution. Its design inherently limits the pilot's peripheral vision. The copilot (front seat station) has the same FOV, but has the advantage of increasing the resolution through the TADS/PNVS. He can normally pick out hazards before the pilot does. With the copilot engrossed in this task, the crew is left without anyone to navigate or fight. The vast majority of early Apache accidents were attributed to wire strikes, and the problem has yet to be totally rectified.

Weapons

The advent of Soviet air-to-air helicopters and anti-helicopter operations has created a void in the American defenses. The Apache presently does not have a air-to-air weapon system. Major General Maurice Cannet, a French officer

who spent his entire career in the French light air arm, contends that the helicopter-mounted gun will continue to be the air-to-air weapon of choice despite the emergence of missile systems. This is because the majority of air-to-air engagements will be inside the minimum range of the missiles. Moreover, no current helicopter gun system is adequate for the air-to-air mission.¹⁷

Cannet's conclusions definitely include the Apache 30mm. The Apache 30mm gun has a widely publicized inherent vibration problem that severely reduces its accuracy. The weapon fires at a relatively slow rate of fire (625 rounds per minute) with low muzzle velocity making it a less effective air-to-air weapon. The lack of an air-to-air missile, and the poor qualities of the 30mm leaves the Apache crew in essentially a purely defensive posture, and potentially vulnerable in the air-to-air combat arena.

Avionics

The Apache communications package has limited transmission range. This is caused by two factors. The environment that the helicopter operates in does not lend itself to line-of-sight (LOS) FM communications. NOE and low-level flight place the aircraft at or below the horizon naturally impeding FM communications. To improve communications, antennas must be placed where the transmission signal is the least attenuated. Apache designers did not take this

into account, and as a result the Apache has difficulty communicating over distances while in the NOE and low-level modes. This presents a serious limitation during cross-FLOT (forward line of own troops) operations. Major Fred Jernigan, a former Apache company commander and Apache battalion S-3 Operations Officer, stated that a temporary fix to this problem was the use of the RU-21 or RC-12 GUARDRAIL electronic surveillance platform. While orbiting behind the FLOT it acts as a radio relay for the Apache units.¹⁸ Without a radio relay airplane, once across the FLOT the Apache crews could not receive intelligence updates, mission changes or spot reports from their unit, nor could they pass the same rearward. This would add significant risk to an already complicated mission.

Sustainment

Rapid return to the battle requires the ability to quickly and efficiently repair, rearm, and refuel the aircraft. The Apache was designed to be rapidly rearmed and refueled while in the FARPs. The refuel portion works as advertised, but rapid rearming has been found to be a problem.

Rearming with rockets and Hellfire is a relatively simple operation. In fact a well trained FARP crew can refuel and the rearm an attack helicopter company with Hellfire and rockets in less than one hour.

Reloading the 30mm has been found to be a difficult proposition, and as a result adds an additional hour to the

FARP time.¹⁹ The 30mm ammunition drum is located far aft and under the fuselage. This makes reloading extremely difficult. Additionally, the gun has been prone to jam when more than 300 rounds were loaded into the drum. This would not ordinarily be significant except that the 30mm gun is the Apache's primary close-in suppression weapon against ground fire from light armor, infantry, and AD systems. Pilots have had to reduce 30mm loads to approximately 300 rounds to prevent delays in the FARP, and improve chances that the weapon will function properly. Reduced loads and improper weapons functioning could place the aircraft and crew in jeopardy.

SUMMARY

The Apache is the premier attack helicopter in production in the world. From its inception in 1971 and fielding in 1986, the Apache was designed using advanced technology. This technology has been the source of many flaws in Apache systems. Correcting these deficiencies has been the major focus of the post-deployment programs while maintaining the combat effectiveness of the Apache.

Future modifications to the Apache include an air-to-air missile system (probably a modified Stinger), an automatic target hand-off system (ATHS), and a millimeter wave radar for use with an advanced Hellfire.

Despite some initial difficulties, the Apache provides the ground commander with unprecedented capabilities that must be understood by all users to be utilized effectively.

THE A-10 THUNDERBOLT II

INTRODUCTION

The introduction of the A-10 into the active Air Force ushered in a new era of combat aircraft. The A-10 was the first airplane designed and built specifically to perform close air support. The engineering included in the airplane accentuated the special needs of the mission, and the interface required by the Army.

ORGANIZATION

The Tactical Fighter Squadron (TFS) is the typical organization where the A-10 is found. The two basic squadron organizations for A-10 units are either 18-ship or 24-ship units. The 18-ship organization is common to Air Force Reserve units, while the 24-ship units are normally in active duty squadrons. Figure 11 depicts the A-10 organization in the Tactical Fighter Wing (TFW).

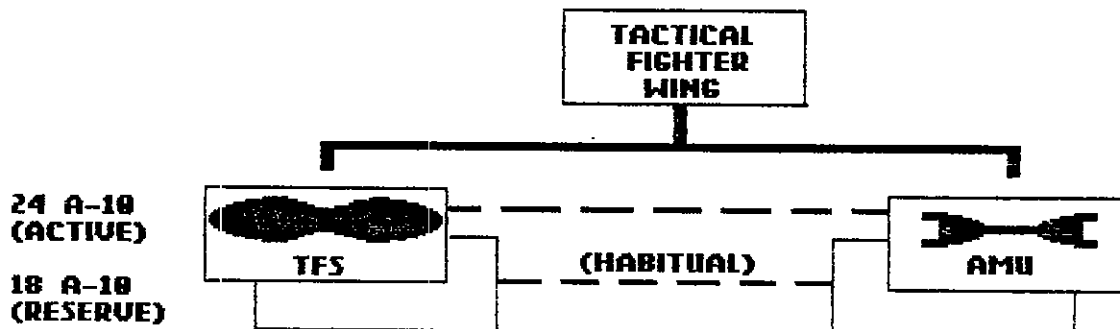

Figure 11
A-10 TACTICAL WING ORGANIZATION²⁰

The TFS, commanded by a Lieutenant Colonel, is further divided into four "flights." Each flight is commanded by a major or a captain, and has six to eight pilots in each flight depending on the type of squadron. Between the pilots are distributed the additional duties of Training Officer, Scheduling Officer, Weapons Officer, Mobility Officer, and Instructor Pilot (IP). Each flight has several IP's for various areas of responsibility which include flight currency, weapons training, and air combat maneuvers (ACM).

The TFS differs significantly from the Army AHB organization in the area of maintenance. The TFS has no integral maintenance capability. All maintenance is provided by an Aviation Maintenance Unit (AMU). The AMU owns and maintains the aircraft of the TFS they support. During peace time operations the AMU is under the command and control of the Wing Commander, but during contingency operations the AMU is attached to the TFS that they support. Normal allocation is for one AMU to support only one TFS, and would only be changed for short durations during contingency operations.

The AMU is a 450-man unit commanded by a major, and is similar in design to the Division Aviation Intermediate Maintenance (AVIM) Company. The AMU is divided into two teams with an E-8 supervising each team. The AMU provides direct and general support maintenance to the TFS as well as providing the rearming and refueling operations. The AMU will be discussed later in the chapter during sustainment.

CAPABILITIES/STRENGTHS

Survivability

The A-10, like the Apache, was designed and built to survive. Its simple, oft described as ugly, exterior belies its inner strength. The pilot is completely encased in a titanium "bathtub" that is impenetrable by all small arms up to 23mm.²¹ The location of the titanium tub is shown in figure 12. The redundant flight control system is protected by armored plating in the pilot's station, and by separating the flight control cables along both sides of the fuselage. The fuel system is composed of tear-resistant internal bladders in the fuselage, and the wing tanks incorporate foam to prevent explosions.

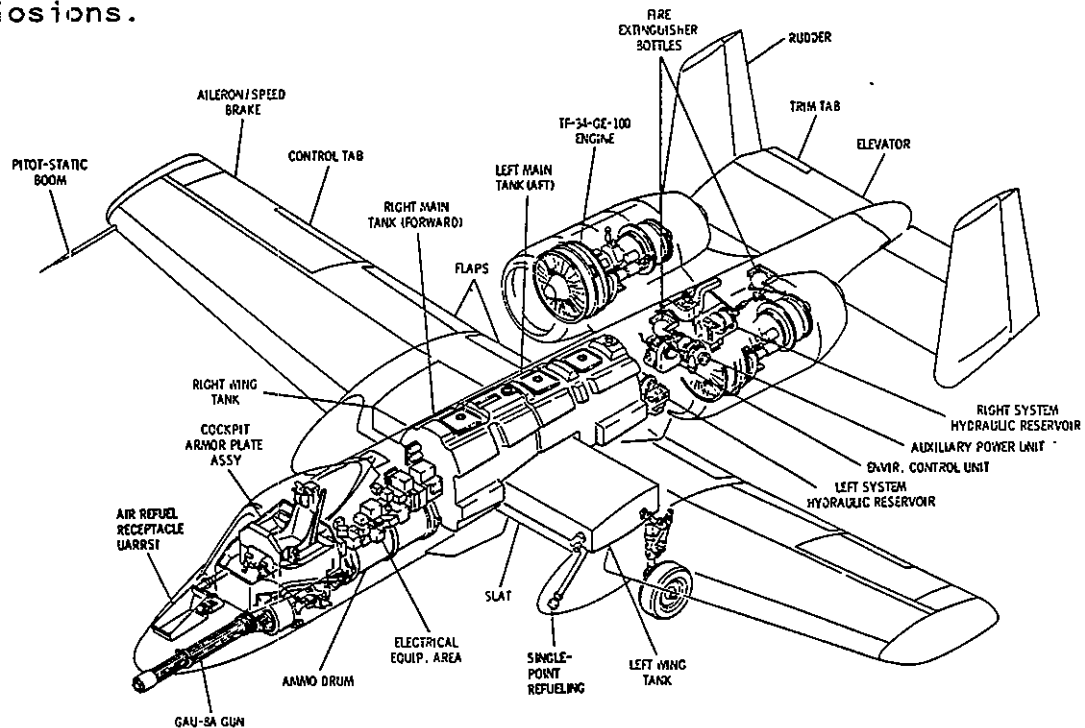

Figure 12

A-10 GENERAL ARRANGEMENT DIAGRAM²²

Source: U.S. Air Force, T.O.1a - 10A A-10A Flight Manual, (20 Feb 1984), 1-2, Fig. 1-2.

The A-10 has a full complement of passive and active electronic countermeasures (ECM). The active systems include chaff and flare dispensers and a radar jammer. The passive capabilities include a radar-warning receiver and the basic aircraft design.

The chaff and flare dispensers are located under the fuselage and on the wingtips of the A-10. The location provides the A-10 the maximum protection from IR seeking and radar guided AD systems from the time that the A-10 unmask for an attack until it remasks after the attack.

To provide passive IR protection, the aircraft designers mounted the engines far aft on the fuselage and horizontally-opposed (see figure 12). Their position forces the engine exhaust plume to the inside of the vertical fins, and reduces the heat signature of the engines. The reduced signature aids in defeating IR seeking missiles. The lateral separation also aids in preventing the loss of both engines if one is destroyed.

Weapon Systems

Certainly the part of the A-10 that is best known to anyone in the need of close air support is its 7-barrel, 30mm gatling gun. The gun and its components, shown in figure 12, are unquestionably the most well-known, and perhaps the most lethal, part of the aircraft as well as one of its primary strengths. Every second, the gun fires 70, 1.5 pound depleted

uranium projectiles at a muzzle velocity of 3280 feet per second. The impact of this kinetic energy weapon is sufficient to destroy all known light armor vehicles, and is capable of destroying most tank and infantry fighting vehicle (IFV) systems.²³

The A-10 was designed to carry a large external payload. It has eleven external pylons that give it the capability for carrying up to 16,000 pounds of ordnance. The external loads could include eighteen 500-pound general purpose iron bombs, six 500-pound laser-guided bombs, 18 Rockeye submunition dispersers, 6 AGM-65 Maverick television or IR-guided air-to-ground missiles, or external fuel tanks.²⁴ Presently the A-10 does not possess the capability of carrying a side-looking-airborne-radar (SLAR) boom like that carried on the Army OV-1.

The A-10 can also carry two AIM-9 SIDEWINDER air-to-air missiles as a complement to the external load.²⁵ The AIM-9 is carried on every fighter aircraft in the United States inventory, and many foreign air forces. The AIM-9 provides the A-10, and ultimately the AJAAT, with a potential offensive air-to-air capability. The AIM-9 is an extremely capable missile that can defeat many ECM equipped advanced threat aircraft.

The Low Altitude Safety and Target Enhancement (LASTE) program provides the A-10 with new capabilities. The LASTE program includes a ground-collision avoidance system (GCAS) to

improve the aircraft's low-level survivability. Also included is an enhanced altitude control system (EACS) that is electronically connected into the aircraft stabilization augmentation system. This provides greater accuracy for the gun in the air-to-ground mode, and dramatically improves the air-to-air capability of the 30mm. During the AJAAT tests in 1989 LASTE equipped A-10's were "extremely effective when employing point-and-shoot tactics in day and night VMC [visual meteorological conditions] reduced threat attacks."²⁶ This is particularly important during engagements when the A-10 pilot does not have visual contact with the target, such as vehicles hidden in a tree line for example.

The addition of the PAVE PENNY laser receiver greatly enhances the A-10's ability to operate with the Apache. The PAVE PENNY receives reflected laser energy from a laser source, either the Apache or another aircraft, enabling the A-10 to lock-on targets at extended ranges. Successful target acquisition and lock-on has been accomplished out to 20 kms.²⁷ From that distance the A-10 pilot had time to evaluate the target, select the weapon, attack the target, and egress from the target area, all outside the effective range of Threat AD systems. Successful target attacks out to ranges of 7 kms using the Maverick missile were commonplace.²⁸ In addition, the use of the Apache laser designator enabled the AJAAT to effectively employ four-ship A-10 sections instead of the usual two-ship.²⁹ The addition of two more aircraft doubles the

available payload and firepower and increases survivability of the aircraft.

Avionics

The A-10 was designed to work for the Army, and the avionics suite was designed to accomplish that task. The A-10 was the first Air Force aircraft to have the Army's Vinson secure-FM capability. The pilot can communicate directly with the person he is providing support to. Additional communications equipment includes a HAVE-QUICK UHF frequency-hopping radio that is also compatible with the Apache UHF radio. The A-10 has the standard complement of navigation equipment to include an inertial navigation system (INS). The INS provides the A-10 pilot with a point-to-point world-wide navigation capability which is essential during self-deployments.

Sustainment

One of the primary reasons that the Army pushed for the A-10's selection during the A-X competition was the simple design of the aircraft. Defence Update International stated that "the aircraft was built with a minimum of requirements for ground equipment."³⁰ This is particularly apparent during Integrated Combat Turnaround (ICT) operations.

ICT is conducted when the A-10 is required to rapidly return to combat after completing a mission. Air Force Major Dewayne Burgess, USAFRES, callsign "Farmer", the Operations

Officer of the 303rd Tactical Fighter Squadron, discussed the capabilities of the ICT teams. He stated that the Air Force Inspector General standards for rearming and refueling and readying an A-10 for commitment with the pilot remaining in the operating aircraft, (known as hot rearming), was 1 hour and 15 minutes. A well trained team was capable of ICT in 20 minutes when loading only fuel and the 30mm cannon, and 30 minutes when also loading an additional two Maverick missiles.³¹

What aids the ICT in this rapid turn-around is the specially designed support equipment and the airplane's simple design. To reload the 30mm a conveyor belt that Burgess called "the dinosaur" is connected right to the aircraft. The expended brass is automatically downloaded, and then fresh ammunition is hydraulically uploaded, all in a matter of minutes. The "dinosaur" is then wheeled away, and the aircraft is ready to refuel. Rapid refuel is conducted through a single-point refueled receptacle located in the left main wheel well (see figure 12).

The A-10 was designed to operate and sustain from forward deployed bases. This type of sustainment required a small deployable package capable of providing continuous support. The support package required for an 18-ship squadron can be airlifted in 20 to 21 C-141-equivalent sorties, depending on the theater and the amount of prepositioned stocks.³²

The A-10 is easily maintained. It "has the lowest maintenance man-hour per flying hour ratio in TAC [Tactical Air Command]."33 The maintenance records for the 303rd Tactical Fighter Squadron for the fiscal year 1990 bear this out. Their overall Fully Mission Capable (FMC) rate average 81.1%, with a monthly low of 71.9% and a high of 85.4%34 During that same period the 303rd TFS flew more than 5000 hours. The AMU was able to repair a grounding deficiency within 24 hours an average of 78% of the time during the entire year.35 Although these are the statistics from only one unit, they indicated that the A-10 is indeed a maintainable aircraft.

A-10 maintenance is provided by an Aviation Maintenance Unit (AMU). The Air Force maintenance program differs significantly from the Army. In peacetime, the AMU is a separate and distinct organization from the TFS that it supports. During contingency operations or periods of conflict, the AMU comes under the command of the supported squadron. All maintenance personnel and equipment are under the control of the AMU including the ICT that was discussed earlier. The AMU, governed by Air Force Regulation 66-5, typically contains 400 to 450 personnel. This is comparable in size to the Army's divisional and corps AVIM Company. The primary difference is that the AMU owns and maintains the aircraft that it provides direct support (DS) and general support (GS) to. The AVIM provides only GS to the division aviation brigade, and does not own the aircraft they support.

Like the Apache, A-10 recurring maintenance is conducted in phases. Phase interval for the A-10 is 400 hours. Based on a 5000-hour flying-hour program and 18 aircraft in the squadron, to meet the flying program the AMU would only have to conduct approximately 13 phase inspections, or less than one phase per aircraft per year. Air Force Reserve Senior Master Sergeant (E-8) Ernest Brazeal is one of the two maintenance team chiefs for the AMU that supports the 303rd TFS. He claimed that the average time for an A-10 phase was two weeks from start to finish.³⁶ The maintenance statistics for the 303rd TFS readily support his claim. The fact that the data is compiled for an entire year adds strong credence to the premise that the A-10 is indeed supportable.

LIMITATIONS/WEAKNESSES

Weapons

The A-10 was designed and built around the GAU-8 cannon. For maximum penetration of hard targets using the GAU-8 the aircraft must close to within 1000 feet of the target. This relatively short attack range is one of the primary reasons for the concern for the A-10's survivability.

At present the A-10 does not possess the night fighting capability that the AH-64 does. The lack of a FLIR and a LASTE system that has reliability problems³⁷ dramatically increases the pilot workload while conducting low-level night

attacks with the A-10, and could decrease the overall effectiveness of the AJAAT.

The A-10 does not have a ground simulator for the conduct of gunnery, ACM, or navigation training. There are however, cockpit mock-ups for emergency procedures training (EPT). The Air Force cost per flight hour in FY90 was \$1275 for the A-10,³⁸ and the lack of a motion-based simulator for training increases the cost of crew training in terms of dollars, aircraft usage, and overall proficiency.

Survivability

The single most discussed deficiency of the A-10 is its speed, or more accurately put, its lack of speed. Opponents of the A-10 have argued incessantly that the A-10 is too slow to survive in a high intensity battlefield. This is one of the primary arguments the Air Force is using for replacing the A-10 as their CAS platform. The concern stems from the A-10 not being able to retain sufficient energy in a pullout to rapidly accelerate and depart the target area. The highly agile A-10 dissipates energy during its high-G maneuvers. Its most vulnerable point to ground and air fired weapons is during pullouts.

During AJAAT, the A-10 is provided protection by either engaging at longer ranges negating the need for high-G maneuvers, or when in close, by coordinated fires from other

members of the team. Proper tactical employment also enhances survivability, and helps compensate for the speed deficiency.

The A-10 does not possess an on-board air-to-air radar system, because an air-to-air threat was not initially envisioned for the A-10. Without a radar the A-10 is not capable of distant early warning of approaching aircraft. The proliferation of Threat helicopter and fixed-wing systems has left the A-10, and the AJAAT, initially in a defensive air-to-air posture. Despite the offensive weapons carried, the A-10 pilot must still visually acquire the target before he can react. This decreases the options and reaction time available to the AJAAT, and can impinge on the ultimate success of the mission.

Sustainment

The AMU does not have the capability to establish off-site rearm and refueling operations, because it does not have the organic equipment to haul fuel or ammunition. The TFS must operate from a fixed-based facility that has established fueling capabilities. In order to operate from austere facilities, as might be required in contingency operations, would require fuel service augmentation. An 18-ship squadron requires nearly 30,000 gallons of fuel for one complete refuel.³⁹ The obvious need for a support base could initially limit the locations that an A-10 unit can deploy to.

SUMMARY

The A-10 has suffered from very limited continued research and development (R&D) since its introduction in 1977. The last A-10 produced in 1984 was essentially no different than the first one. With the exception of the LASTE system and the Pave Penny system, which are incorporated on other Air Force aircraft, the A-10 has not had any upgrades. As recent as June 1989, the only A-10 at the Air Force's Flight Test Center at Edwards Air Force Base, California, was the one-of-a-kind two-seat version in their museum.

The 1989 CASADA review recommended that FLIR, automatic target hand-off system (ATHS), and a helmet-mounted display, all of which were on, or to be on the Apache, be incorporated in 225 A-10's dedicated for CAS.⁴⁰ They concluded that these improvements along with newer, more powerful engines, would continue to make the A-10 a viable platform for the AJAAT.

The AH-64 and the A-10 were designed and built without regard to the others strengths or weaknesses. Yet the mating of the two systems has enhanced their relative strengths, and reduced their relative weaknesses. The A-10 can provide medium and short-range air-to-air protection for the Apache. The Apache provides long range day/night target acquisition and designation for the A-10 which provides standoff and survivability. They both provide suppression for one another during attacks.

The complementary nature of both systems has been borne out consistently during joint DOD tests, as well as unit-to-unit coordinated training exercises and major field training exercises (FTX). Unit-to-unit exercises are not considered the proper method of coordination, but the need to conduct training has forced Army and Air Force units to operate in this manner.

Both aircraft will continue to perform as a successful team. Any future enhancements to the aircraft will only serve to enhance their capabilities as a team and extend their service life.

CHAPTER 3 ENDNOTES

1. Brooke Nihard, "Packard Review Group: Roles and Missions to Remain Untouched, Aircraft Systems to be Scrutinized," Armed Forces Journal, (19 April 1971), 20.
2. Apache Fielding Plan from the Department of the Army DCSOPS, AH-64 System Integrator dated 12 August 1989.
3. Apache Fielding Plan, and "State of the Force, the 1990 USAF Almanac," Air Force Magazine, (May 1990), 51, 125.
4. Apache Fielding Plan.
5. U.S. Department of the Army, FM 1-111 Aviation Brigade, (U.S. Government Printing Office, Washington, D.C., August 1986), p. 1-4.
6. U.S. Department of the Army, FM 1-112 Attack Helicopter Battalion, (U.S. Government Printing Office, Washington D.C., July 1986), p. 1-1.
7. FM 1-111, p. B-1.
8. Norman B. Hirsch, "AH-64: Total System for Battle," U.S. Army Aviation Digest, (July 1986), 2.
9. Ibid., 7.
10. Robert V. Mitchell, interview by author, Carlisle Barracks, Pa., October 1989.
11. Fred W. Jernigan, interview by author, Fort Leavenworth, KS., November 1990.
12. GAO Report to Congress, "Apache Helicopter, Serious Logistical Support Problems Must be Solved to Realize Combat Potential," (U.S. Government Printing Office, Washington D.C., September 1990), i.
13. U.S. Congress, Congressional Record, Tuesday, 12 June 1990, (101st Congress, 2nd Session), p. S7830.
14. Ibid.
15. William W. Powell, interview by author, Fort Leavenworth, KS., November 1990.
16. Jernigan interview.
17. Maurice, Cannet, "Air-to-Air Fighting With Helicopters," International Defense Review, (August 1988, vol 21), 955.

18. Jernigan interview.
19. Gordon R. Lester, interviewed by author, US Naval Test Pilot School, Patuxent River, Md., June 1990.
20. Dewayne Burgess, interview by author, tape recording, Richards-Gebaur Airfield, Kansas City, Mo., December 1990.
21. Ibid.
22. U.S. Department of the Air Force, T.O. 1a-10A A-10A Flight Manual, (U.S. Government Printing Office, Washington D.C. 20 February 1984 with change 1 30 March 1984), p. 1-2.
23. Steven Weaver, interview by author, Ft. Leavenworth, Ks., January 1991.
24. Naval Institute Database, latest update 21 March 1989.
25. Ibid.
26. Scott A. Reynolds, A-10 Joint Air Attack Team With Improved Helicopter Tactics Development and Evaluation, (Final report from the 57th Fighter Weapons Wing, Nellis AFB, Nv., JULY 1987, SECRET), p. VI.
27. Mark Ferrell and Scott Reynolds, "Apache Thunder," U.S. Army Aviation Digest, (May 1989), 6.
28. Reynolds, p. VI.
29. Ferrell, 5.
30. Defence Update International, "Warthogs in Action," (Number 72), 30.
31. Burgess interview.
32. Ibid.
33. Thomas J. Monforte, "Contemporary CAS: Problems and Prospects," (Student Research Report, U.S. Army War College, Carlisle, Pa., 23 March 1987), 26.
34. 442nd Tactical Fighter Wing "Monthly Key Indicators," Maintenance chart of the 303rd TFS for the period Nov 1989 to Oct 1990 for the A-10A aircraft. Document received during Burgess interview.
35. Ibid.

36. Ernest Brazeal, interview by author, tape recording, Richards-Gebaur Airfield, Kansas City, Mo., December 1990.
37. Burgess interview.
38. Ibid.
39. A-10A Flight Manual, p. 1-15.
40. Naval Institute Database.

CHAPTER 4
OPTIONS FOR CONDUCTING AJAAT OPERATIONS

INTRODUCTION

This chapter will describe, discuss, and compare three options for the conduct of AJAAT (advanced joint air attack team) operations. The options will be compared in the context of planning and executing AJAAT operations, command and control (C²), and combined training considerations. The three options considered are: 1) current AJAAT doctrine; 2) the 1989 Army concept study for assuming the entire close air support mission; and 3) the integration of the A-10 into Army corps aviation attack regiments as a result of the 1991 National Defense Authorization Act.

AJAATs are either preplanned or immediate, and the planning and C² considerations for either are significantly different. The following discussion will look at the planning process from mission receipt to execution, and will identify the strengths and weaknesses of each option. Discussion of command and control considerations will primarily focus on the execution phase. The other major area to be examined is how Army and Air Force units conduct AJAAT training, with whom, how often, at what level, and to what standard.

AJAAT operations are able to stretch the width, and depth of the battlefield when properly planned, resourced, and

executed. What is least understood about AJAAT operations is where these operations are most effective.

It is the author's experience that preplanned AJAAT operations should be focused at targets forward of the FLOT, also known as deep targets. Deep is a relative term depending on the level of command, and is usually based on the range at which commanders can affect the battle. For instance 15kms is considered deep at the brigade level, because artillery is the brigade primary deep asset, while 150kms is considered deep for corps based on electronic warfare and aviation assets.¹ Regardless, the term "deep operations" applies equally at all levels of AJAAT planning.

Immediate AJAATs are the most difficult to coordinate, but are the most likely to occur. They are normally associated with operations in unit rear areas, or in response to a breakthrough, or with the appearance of a fleeting target of opportunity and the only elements available to rapidly respond are air maneuver units. Rear areas must be large enough to provide emplacement of reserves and combat service support units. In some instances the rear area may be as large or larger than the main battle area.

AJAAT operations in close proximity to friendly armor or mechanized units should be avoided if at all possible. Such operations are not the forte' of AJAAT operations. They are the most dangerous to the team, and the least productive

in terms of target effectiveness. A very definitive after-action-review (AAR) comment from the National Training Center (NTC) indicated that "JAAT aircraft cannot differentiate between enemy/friendly targets in the close battle."² This is certainly not an absolute truth, but it does serve to illustrate the difficulty in close operations. This difficulty was borne out with devastating results during Operation DESERT STORM.

The first American ground combat casualties of Operation DESERT STORM were the result of a Maverick missile fired from an A-10 at a friendly vehicle mistaken for an enemy personnel carrier. The aircraft was under the control of a ground forward air controller (GFAC), and was not participating in a JAAT when the ordnance was delivered. This travesty was repeated several nights later when an AH-64 unit responding to a call from a front-line unit, destroyed two friendly vehicles the pilot mistook as enemy. Both of these accidents occurred at night, and vividly demonstrate the difficulty aircraft have in conducting operations near the friendly line of troops.

The common denominator for fighting the AJAAT in the close, rear, and deep battle is and will continue to be the attack helicopter commander.

OPTION 1: CURRENT DOCTRINE

THE AJAAT PLANNING PROCESS

Major problems. . . have been encountered in the preparatory planning and organization process necessary to bring the JAAT assets together in the battle area.³

FM 90-21

FM 90-21 is a joint manual for conducting AJAAT operations. It is a "how-to-fight" manual that unfortunately omits a great deal of the "how-to." It does however, highlight the depth of resolution required for planning AJAAT operations. Other key doctrinal manuals devote little attention to the subject of AJAAT/JAAT operations. FM 71-100, Division Operations, and 71-3, Armored and Mechanized Brigade operations, devote only one half-page each discussing JAAT operations.⁴ The corps operation manual, FM 100-15, does not address JAAT at all.⁵ The inadequate depth of doctrinal literature raises the question as to whether the Army considers AJAAT/JAAT as a viable operation. Is there any wonder that commanders have trouble integrating JAAT into their scheme of maneuver, or that brigade, division and corps staffs find JAAT operations difficult to plan and coordinate?

Preplanned Operations

AJAAT operations are conducted under corps, division, or maneuver brigade control. The goal of the AJAAT is the same at any level: to enhance the ground commander's scheme

of maneuver. To conduct these operations requires the assembly of the team. Under current AirLand Battle (ALB) doctrine, the corps and division are the only command levels that have organic attack helicopters.

All requests for close air support go to the corps, because Army units do not presently have organic A-10's, and must rely on allocation of these assets from Air Force theater resources.

AJAATs conducted under corps and division control are planned by aviation brigades within that command. Planning is completed in concert with the attack helicopter battalion(s) that participate in the mission. The AHB staff is involved from the inception, but it lacks the depth in the planning staff to adequately conduct future operations planning. It requires support from higher staff elements to complete the plan, because their staff lacks an air liaison section, air defense liaison officer (LNO), or engineer LNO.

The current Army focal point for AJAAT planning is normally no lower than the maneuver brigade.⁶ Within the brigade staff, the S-3 Air is the officer normally tasked with AJAAT planning. He is not an Army aviator, but he is expected to be completely versed in Army aviation strengths and weaknesses, and current employment doctrine. The Air Force liaison officer (ALO) in the S-3 section assists in the planning. On occasion, an Army aviation LNO may be assigned.

The Aviation LNO is not an organic asset, and is only allocated when the attack battalion is placed under operational control (OPCON) of the maneuver brigade. These are the three personnel that are responsible for planning AJAAT for the maneuver brigade.

FM 90-21, indicates that regardless the level of command conducting the mission, preplanned AJAATs require a minimum of 36-48 hours planning time prior to execution.⁷ This time estimate is predicated on two considerations. The first and primary consideration is the time to process the tactical air (TACAIR) support request through the Air Force channels. The TACAIR request must travel through the entire Army and Air Force request channel, be reviewed, and then be sent back to the requester. The preplanned JAAT request channels are depicted in figure 13.

The approved request is transmitted to the Air Force in an Air Tasking Order (ATO). The current ATO cycle is 36 hours, and an AAR comment from the 1986 Exercise BOLD EAGLE indicated that the ATO process was unresponsive. The observer reported that a redirection in the air effort would take three days to orchestrate, and that was unacceptable.⁸

The corps planning cycle the other constraint in the time equation. The corps planning cycle averages 96 hours for a combat order. Using the standard "one-third/two-thirds rule" for operations planning, (one third of the available planning time is for the higher command, and two-thirds is for

the next lower echelon for their planning), the subordinate divisions would get 72 hours for planning. Continuing down the planning chain, the brigades within the division would get 48 hours to plan their operation. As previously mentioned, thirty-six hours is the minimum time estimated for preplanned CAS requests to filter through Air Force channels. This puts considerable pressure on the brigade planners. They must conduct their mission analysis, determine the threat arrayed against them, and ascertain if additional assets such as attack helicopters or CAS are required.

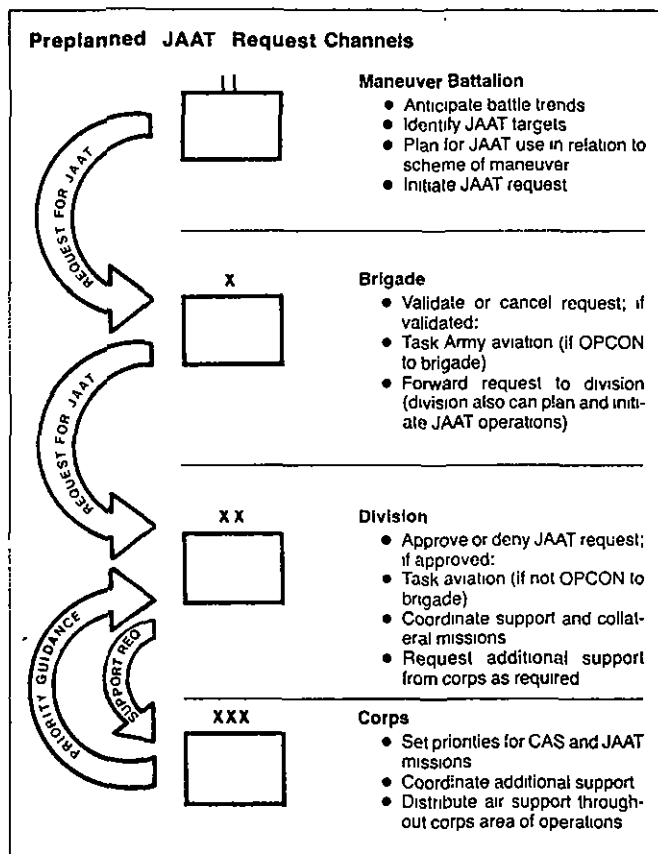

Figure 13
 AIR FORCE TACAIR REQUEST CHANNEL⁹
 Source: Kelley and Huffman, "JAAT Planning: Getting the Most From Synchronized Forces," (Field Artillery Journal), 36.

The corps tries to facilitate subordinate planning operations by allocating anticipated CAS assets to subordinate units. Allocations are not guaranteed, but do provide commanders with a basis for planning. This allocation may also include corps attack battalion assets to the units that are anticipated to have a need for those assets.

The division may also allocate AHB assets to the maneuver brigade. The decision to place the attack battalion OPCON to a brigade either comes from the division allocating the asset based upon the brigade's mission, or after the brigade commander requests their use from the division commander. In divisions with only one AHB, the division commander may have other missions forecast for them, and may elect not to allocate that asset to the brigades. In many cases the AHB is used as the division reserve because of its versatility. An alternative is to request additional AHB assets from the CAB. This process is undertaken as the planning clock continues to tick toward H-hour.

If approved, an attack battalion LNO is dispatched as the planning for the operation continues. By this time there is less than 36 hours remaining before execution. The author shared in the frustration of the battalion staff during his two NTC rotations as an attack helicopter company commander. The AHB staff habitually received warning orders from the supported brigade 18 hours prior to H-hour. The battalion was left little time to prepare their order, receive approval from

the brigade, and conduct the necessary coordination prior to execution time.

The complexities of fire support created its own problems during the author's NTC experiences. On several occasions the final fire support plan was not delivered to the attack commanders until just prior to launch. Dissemination to subordinate platoon leaders and other pilots was not possible. This rendered the plan close-hold rather than maximum-use as it was intended. The loss of the commander would have meant the loss of the entire fire support plan.

Face-to-face coordination is not normally possible with the Air Force unit conducting JAAT operations before or after the operation. A-10 planning is done by the brigade ALO. Likewise, joint rehearsals are not normally conducted either. Rehearsals between Army and Air Force aviation assets would have been extremely beneficial. Supporting artillery should be included in any rehearsal. Rehearsals would help players exercise the operation, identify any possible deficiencies, and determine communications nets that each element would operate on.¹⁰

AAR's that include the Air Force air crews are again not normally conducted; therefore, lessons learned are neither adequately captured nor adequately disseminated. A clear indication of this is the extremely limited AJAAT/JAAT AAR data on file at the Center for Army Lessons Learned (CALL) library.¹¹

AJAAT planning has extensive requirements. Figure 14 lists some of the specific planning considerations and coordination required for conducting AJAAT as outlined in FM 90-21.

- * Nature and size of target.
- * Target activity.
- * Target priorities.
- * Alternate targets/contingency plans.
- * Enemy avenues of approach.
- * Enemy air threat/type/location.
- * Friendly artillery that can support the operation.
- * SEAD/J-SEAD planning.
- * Friendly AD weapons control.
- ** Communications: means and frequencies.
- ** Laser codes.
- ** Downed pilot procedures.
- * Time-on-target.
- * Weapons configuration.
- * Airspace deconfliction.
- * Location of friendly units.
- ** Tactics and attack options.
- ** Weather.

Figure 14
AJAAT SPECIFIC COORDINATION¹²
(Source: FM 90-21)

The list is not inclusive but serves to describe the depth of planning and coordination required to perform an AJAAT mission. The items that are double-starred are aviation-specific requirements that require coordination between Army and Air Force air elements. The AJAAT operation is but one part of the overall brigade plan, albeit an important one, and it requires specific planning considerations.

Immediate AJAAT Planning

Immediate AJAAT planning is an undefined premise. It is not doctrinally specified or delineated under any existing tactics, techniques, and procedures (TTP). Immediate AJAAT, as the name implies, must be accomplished without the luxury of planning time, detailed coordination, or rehearsals. It is truly the essence of a "come as your are" operation. As mentioned previously, a situation demanding immediate AJAAT might occur when an enemy penetrates the main battle area, or if an unexpected threat attacks in the rear area. Incumbent upon the planning staff is identifying the complete threat capabilities throughout the width and depth of the battlefield, and then prioritizing them in order of likelihood of occurrence. These then become contingencies. This is the procedure at all staff levels. The lower the level, the fewer the contingencies, and the fewer the assets available to deal with contingencies.

FM 1-111, Aviation Brigade, states that the corps attack regiments could "serve as the planning headquarters for contingency operations [immediate AJAAT]".¹³ Since all contingencies cannot be adequately planned for before the battle, immediate AJAAT's sometimes result in ad hoc control measures coordinated over the radio between the AHB commander, the AFAC, and the fire support element. The author's experiences at the NTC bear witness to this situation. The AHB was used extensively with and without A-10 support, in an effort to

blunt a penetration in the main battle area as the enemy raced for the rear area. Air space coordination was solely the responsibility of the JAAT commander, because the friendly C² was in disarray or destroyed.

The lack of established Immediate-JAAT battle drill, doctrinal TTP, and unfamiliar aircrews added to the already confused battle. One alternative to this problem is the use of theater-wide Standard Operating Procedures (SOP). This remains viable except in contingency theaters with forces from different geographical areas, as was the case in Operation DESERT STORM.

COMMAND AND CONTROL

The maneuver commander has overall responsibility for the employment of a JAAT.¹⁴

The command and control of AJAAT operations is dependent upon the level of command. At the corps level, "the corps commander has a definitive means to pursue the operational and tactical levels of war."¹⁵ When corps retains control of the attack regiment, FM 1-111 states: "the [corps aviation] brigade headquarters should be used as a C² element similar to any other maneuver brigade headquarters."¹⁶ When the division commander retains the AHB under his control, C² is the responsibility of the Assistant Division Commander-Maneuver (ADC-M). The AHB commander reports directly to him. If the division assigns the aviation brigade a mission that would include the AHB, then the aviation brigade

commander is responsible for C². Likewise, the brigade staff would conduct the in-depth planning. When the AHB is placed OPCON to a maneuver brigade,, the maneuver commander is responsible for C². Like operations under division control, for that operation the AHB commander would work directly for that commander as if the AHB was part of his organization. The brigade commander would expect the AHB commander to provide him with expert counsel as to the time and place for employment of his unit.

EXECUTION

The most difficult phase of AJAAT operations is execution. The following scenario will serve to illustrate the complexity of executing AJAAT.

A friendly division is in a defensive position awaiting threat attack. An AHB, under maneuver brigade control, has been given the mission to attack cross-FLOT, and destroy the lead battalions of the enemy second-echelon regiment to prevent their employment in ongoing close operations. The AHB commander, after consulting with the brigade commander, determines that the situation is ideal for JAAT and warrants the allocation of A-10 assets. He asks the brigade ALO to request A-10 support, and the request is approved. The brigade ALO and the AHB staff develop the plans, and the commander issues his order. At the prescribed time, attack helicopter companies depart assembly areas enroute to a preselected attack

position. Depending upon their mission, the AHB assembly areas may be as close as 25kms and as far back as 100kms from the FLOT.

Elsewhere the A-10's depart their base far to the rear and fly forward to a rendezvous point. The A-10's working from a forward deployed base concept, as in Europe, are more than 150kms from the FLOT.

Next, the AHB units move into battle positions and prepare to engage the threat. Preplanned artillery is alerted and prepares to fire. The AHB commander or his designated company commander establishes communications with the Air Force airborne forward air controller (AFAC). This is a critical point in the mission, because if communications cannot be quickly established between the AHB and the AFAC, gaining control of the A-10 aircraft may be delayed which may disrupt the attack plan. As a backup, provisions are made for direct contact by the AHB with the CAS aircraft in the event of the loss of the AFAC. Distance often hinders establishing timely communications.

A recurring problem is incompatible authentication tables between the services. The AFAC can authenticate with the inbound A-10's and Army units, but the Army cannot authenticate with the A-10's. The Army and the Air Force use completely different authentication tables. The dissemination of the Air Force tables does not currently include Army

Aviation units. This is particularly critical in the absence of the AFAC.

The A-10's arrive at their Contact Point (CP), and report in to the AFAC. Standard procedure is for the AFAC to authenticate with the A-10 team before passing intelligence updates and the mission order. The AFAC briefs the aircraft on the current enemy situation and delivers the standard briefing. The AFAC then passes control of the A-10's to the AHB commander for the conduct of the AJAAT.

Upon completion of the mission, or when directed, the A-10's return to the control of the AFAC for release to another mission or exit from the battle area. The AFAC receives the A-10 pilot's battle damage assessment (BDA) and any AAR comments. The AFAC is then responsible for passing those comments to the AHB and ground commander. The AFAC lacks the battlefield perspective that the A-10 pilot has; consequently, he may not be able to accurately assess the total battlefield picture.

Immediate AJAAT

Conducting immediate AJAAT is no different than preplanned AJAAT once all the players are in place. Getting the players to the fight is the critical event in this operation.

The operation cannot start without a threat. Only after a threat is identified can the mission commence. The

ground commander then initiates the process with an immediate request for Air Force assets. This request follows a different path than the preplanned air request shown earlier. Figure 15 shows the immediate request net.

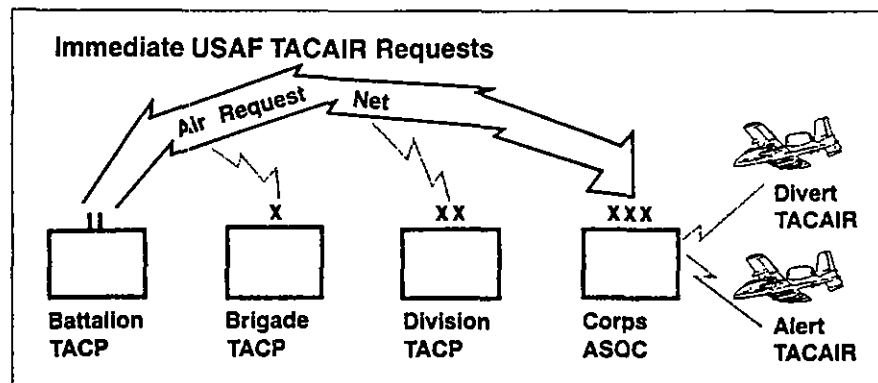

Figure 15
 AIR FORCE IMMEDIATE AIR REQUEST NET¹⁷
 Source: Kelley and Huffman, "JAAT Planning: Getting the Most From Synchronized Forces," Field Artillery Journal, (Feb 1988), 37.

The immediate net operates as rapidly as is possible, but the minimum time for approval of a request is approximately ten minutes. A Russian armor column in pre-combat formation moving at combat speeds could travel more than 3kms in that 10 minutes.¹⁸ For a request to be approved there must be aircraft to allocate.

Two methods of allocation are normally practiced. An aircraft that was previously allocated to another unit can be diverted. Before diverting aircraft, the mission planners would consider the aircraft type, ordnance on board, and the time required to reach the target area. Commanders requesting immediate JAAT or CAS must understand that the unit that

originally planned for the employment of those aircraft is at least temporarily without their air support.

The second method is to launch aircraft that are on "strip alert." These aircraft are poised to launch within a specified amount of time, usually five minutes. As previously mentioned, the A-10 is launched from airfields more than 150kms behind the FLOT. For a worst-case example, assume the target area is at the FLOT, and the aircraft travels at 480kms per hour (300 mph). At least thirty-five minutes will have elapsed between the time the request was initiated and the aircraft arrives at the target area. Based on the previous march speed, the enemy column could have traveled nearly 12kms.

Getting the AHB to the fight may also be a problem. If the AHB is not already committed, it too will have to be alerted. If it is committed and in contact, it will have to disengage, and perhaps require rearming and refueling. FARP operations discussed in chapter 2 could take an hour to accomplish. Normally considering time-distance factors, the AHB will be the first to arrive at the engagement area, because it's simply closer. However, the AHB would take twice as long to arrive at the battle if it is located the same distance from the battle as the A-10.

The commander then must make a rapid assessment of the situation, determine a course of action, and execute his mission. That is simplistic to say the least. There is a

multitude of coordination necessary including coordination with the ground commander for airspace deconfliction, AD support and status, as well as ascertaining artillery availability and then integrating all those systems. Also necessary is determining whether or not an AFAC is airborne. If an AFAC is not available, how will link-up with the A-10's occur, and where, and on what radio frequency? The ALO or ASOC (air support operations center) may be able to effect the hand-off. They must also have communications with both air units. Unless other arrangements have been pre-coordinated, the incompatibility of authentication tables between the Army and Air Force may restrict use of Air Force assets.¹⁹

An immediate AJAAT can be the epitome of chaos, or the epitome of synergism. It is a mission which lends itself to "battle drill." Battle drills are actions that are practiced repeatedly until they become second nature. Failure to regularly practice and develop battle drills with A-10 units, could result in less effective immediate AJAAT operations.

TRAINING

The inability to frequently train with Air Force CAS squadrons is a severe limitation of the current doctrine. This significantly limits effectiveness on the battlefield.

Practicing battle drills with Air Force CAS units is often difficult to schedule during peace time. Conducting live-fire gunnery training is even a greater challenge. Under

current training doctrine, Army aviation units normally conduct aerial gunnery only twice a year. Competition for range space, and ammunition allocations are some of the limiting factors. Most Army posts have very few areas that permit actual live-fire maneuver training with attack helicopters and A-10's. The problem is the result of relatively large safety fans that attack helicopters and Air Force aircraft require under peacetime constraints.

Gaining maneuver training space for use in force-on-force training requires nearly the same level of administrative resolution as gunnery training. The inclusion of attack helicopters and CAS aircraft is usually predicated upon the wants of the ground maneuver unit. Although not impossible, the system could be dramatically simpler if the aircraft were a constant participant.

The proximity of A-10 units to Army AHB's is also a limiting factor. There are not presently any A-10 and Apache units currently co-located at the same base/fort. Many A-10 units have to fly hundreds of miles to conduct training with Army units (see figure 8, chapter 3).

A large number of A-10 units are in the reserve. This means the vast majority of their training is done on the weekends. This has two limiting factors. First, the vast majority of sorties flown would be limited to the weekend. This either drives the Army training program to be focused on weekends, which has severe morale implications, or it severely

limits the use of CAS assets during other training normally conducted during weekdays.

Training, regardless of the day of the week, is important. Training with only a portion of the unit as with reserve units on weekends, while still important, does not permit the development of standard operating procedures (SOP's) or battle drill.

As a rule, habitual association is not practiced between Army and Air Force units. Units that do workout scheduling problems and which habitually train together can develop effective SOP's.

One disadvantage to habitual association under current doctrine is deployments in support of contingency operations. Units that habitually train together are not necessarily planned to deploy together. Operation DESERT SHIELD was a classic example of that. This would certainly create some initial confusion between units upon arrival in the theater of operations. This initial confusion would certainly be reduced if the units had trained together. The training partnership enables the Army and Air Force pilots to anticipate problems and have solutions ready, and in the end execute more effectively combat operations.

OPTION TWO: THE ARMY CLOSE AIR SUPPORT BRIGADE

The Fiscal Year 1989 Department of Defense Authorization Act required the Department of Defense to conduct a feasibility study for transferring the entire CAS mission from the Air Force to the Army.²⁰ This study conducted by the Training and Doctrine Command (TRADOC) Concepts and Doctrine Division at Fort Leavenworth, included the transfer of all A-10 aircraft, pilots, enlisted maintenance personnel, equipment, and certain Tactical Air Control System (TACS) elements to the Army.²¹

The TRADOC study advanced the Close Air Support Brigade (CASB) as the structure of the Army to conduct the CAS mission. Figure 16 depicts the CASB.

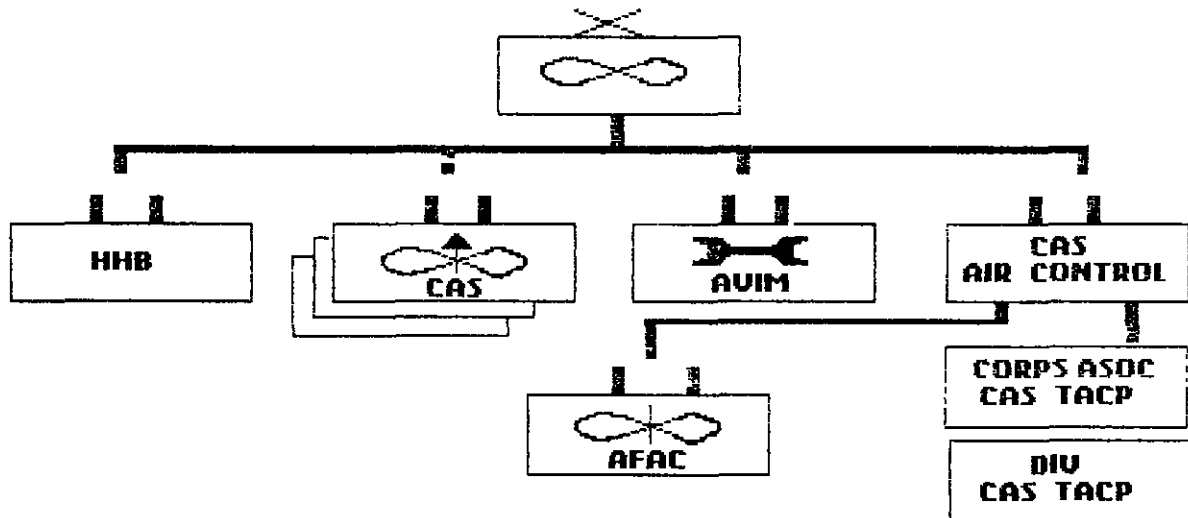

Figure 16
THE CLOSE AIR SUPPORT BRIGADE²²
(Source: 1989 TRADOC Study, 12.)

The CASB is not a part of the CAB, but is similar in many respects. "The CASB headquarters is modeled after the existing aviation brigade headquarters and serves the same functions of planning, execution and logistic sustainment."²³ The CAS squadrons are the heart of the CASB. The squadron appears to be identical in structure and composition to the current Air Force squadron shown in figure 11, Chapter 3.

PLANNING

Preplanned AJAAT Operations

Under the option, the corps commander controls all the assets required the conducting AJAAT operations, but this option includes the added requirement to conduct CAS. This means that the limited CAS assets at corps (the A-10-equipped CASB) will have to be divided between the two missions.

The corps is now responsible for issuing the ATO (air tasking order) for CAS aircraft under its control. Before, the Air Force at theater-level would issue the ATO after the theater commander determined his priority for allocation. The CASB option still allows for centralized control of the CAS assets, but at a lower level, and under one component commander.

The issue that has yet to be resolved is the differentiation between CAS and battlefield air interdiction (BAI). Corps has responsibility for its deep battle, and it is here that CAS and BAI targets blend. The Air Force would retain

the Tactical Air Control parties (TACP) at the theater and corps level to plan BAI and air interdiction (AI) missions. The TRADOC study concluded that "separating the missions [CAS and BAI] would complicate the planning and control procedures and degrade combat effectiveness."²⁴

AJAAT under current doctrine is defined as a submission of CAS, but the planning for each is unique. CAS is allocated to the divisions, and then sub-allocated all the way down to the battalion level for planning and execution. Yet, because of its inherent limitations, such as available station time, target identification, and the lack of true all-weather capability; ground commanders cannot rely on CAS in and of itself to be decisive. CAS is integrated into the scheme of maneuver as a fire support asset just as field artillery is.

The Air Force TACP assets currently assigned to the battalions for planning CAS missions will become Army assets under the TRADOC option. This is another area that has yet to be resolved. The Air Force ALO is a school trained pilot on a one-time assignment as an ALO. The Army does not have school trained "ALO's", and the question to be resolved is whether the TACP position would be an additional duty, or permanent position on the staff.

If enacted, the shift of the CAS mission would only move the A-10 to the Army. The other aircraft used previously in CAS missions, the A-7, F-4, and F-16, are retained under Air Force control, and are not available for allocation by the

corps commander. These aircraft can certainly conduct CAS, and undoubtedly would, but under whose control? The author makes the assumption that the use of these assets will be based upon current doctrine where the theater commander assigns the priority and the Air Component Commander (ACC) fills the requirement with his assets. Priorities would likely be BAI-type targets, with CAS being a lower priority.

A major deviation from current Army doctrine is where the focus for planning is placed. "The CAS battalion will achieve battlefield success through centralized planning and . . . decentralized execution."²⁵ The CASB would conduct the bulk of planning for their battalions. If the organization is modeled after the AHB, it too would lack all the sections for complete planning.

The battalion is envisioned to be task organized to support the corps and subordinate divisions. The battalion has four companies, and a total of 18 or 24 A-10 aircraft. Each company would have between four to six aircraft; therefore, typical employment would probably be by company, or smaller. The battalion acts as the broker for distributing assets to the supported units. This necessitates that the planning be conducted by the CASB.

The current aviation brigade staff structure does not include all the necessary coordinating sections. The missing pieces are the lack of an TACP section, which would be redundant in the CASB, an aviation LNO, and an AD section.

The allocation of an aviation LNO would still be based upon mission tasking. The lack of the LNO diminishes the capability to plan AJAAT missions just as with the current doctrine. The lack of an AD section hinders airspace coordination, which is currently conducted by the corps staff.

The CASB is not included in the corps aviation brigade structure. It is a separate organization of equal stature to the CAB. The CASB and CAB would have to be directed by a corps operation order to conduct combined operations. The planning for any combined operation would likewise be the responsibility of the corps staff. As with the current doctrine, subordinate units requesting CAS to conduct AJAAT would have to compete with the corps commander's CAS priorities.

The potential corps CAS assets will not approach what is presently available. As mentioned previously, the Air Force would retain the A-7, F-16, and F-4 aircraft which have historically conducted CAS as part of their mission. The A-10 would be the only CAS asset directly available to the Army commander. This may preclude large allocations for subordinate units in order to provide the corps commander with a flexible reserve force.

Immediate AJAAT Planning

Immediate AJAAT planning will not significantly change under the CASB concept. Corps, division, and brigade planners will seek to identify all potential contingencies. The difference will be that contingencies identified during planning will now have fewer CAS assets available to allocate for planning. This may lead to less and less reliance on CASB assets to conduct missions, and more and more on internal assets. This may result in the increased use of attack helicopters without A-10 support simply because A-10's are performing CAS elsewhere. This use has already been shown to reduce the effective lethality, and increase the vulnerability of the helicopter and A-10.

COMMAND AND CONTROL

Command and control under the CASB concept varies directly with the level of employment and basis of allocation. If retained at the corps level as a reserve, the CASB commander would probably be the C² authority for his unit, but it could just as likely fall to the commander that the aircraft are allocated to.

There is not any indication within the TRADOC study that suggests how C² would be conducted under AJAAT operations, particularly if allocated to the division or lower. One option would be a task force under the control of the CAB or CASB commander. This option would only be valid if corps

allocated the entire aircraft package. Another option would be piecemeal allotment to the subordinate unit. In this case the maneuver commander would exercise C² as well as planning. As mentioned previously, the inability to diffuse the BAI and CAS line creates a C² problem that becomes further complicated with the inclusion of AJAAT into the equation.

EXECUTION

Preplanned AJAAT Operations

Preplanned AJAAT missions would be conducted essentially in the same manner as current doctrine. Division and maneuver brigade-controlled AJAAT missions would see no significant difference in planning.

The AHB being a division asset would join the A-10 on the battlefield as before. One difference from current doctrine would be that the AFAC would also be an Army asset. A CALL after action report indicated a significant problem in common terminology between ground maneuver commander and the air support element.²⁶ This problem would likely be eliminated if the CASB was an Army asset, because the Army operates on common verbiage among all the branches. This is essential to effectively synergize that asset with the other members of the combined arms team.

Likewise, the lack of a common authentication would be mostly eliminated. The CAS aircraft retained by the Air Force and the Army AFAC would still have incompatible authentication

tables. This creates a problem that was not present under current doctrine. The AFAC may not be able to control Air Force CAS assets allocated to his area. Provisions would surely be made to get the AFAC the proper table, but the loss of the AFAC would still present the same authentication difficulty to the ground units as presently exists.

Corps orchestrated AJAAT missions offer the potential for face-to-face coordination prior to execution. This would be dependent upon unit locations, time available, and other factors, but the possibility is there. Special situations under current doctrine also offer this possibility, but certainly not at the frequency that the TRADOC option presents.

TRAINING

Peace-time training opportunities between the AHB and A-10 units would be substantially improved under the CASB concept. The attack helicopter and CAS units should be able to conduct much more combined training. The CASB and CAB would undoubtedly develop separate SOP's, and would in all likelihood exchange them with one another. This would go a long way toward developing an improved tactical training relationship. The problem of gunnery range training would likely still exist, but with effective SOP's and prior combined pre-gunnery training conducted, gunnery training should be more effective.

A limitation to this option would be the additional requirement for the CAS units to concentrate on CAS training, as it is their primary mission. This would possibly create the linking of CAS squadrons to divisions for habitual association. This would further decentralize CAS resources, and prevent massing. The employment of CAS assets within that division would be at the discretion of the commander, and subject to his prejudices and experiences. AJAAT would likely fall into this category.

OPTION THREE: THE CORPS AIR ATTACK TEAM REGIMENT

The corps Air Attack Team Regiment (AATR) is a conceptual organization that the author developed to best utilize the A-10 once it is incorporated into the Army. The organization is a further development of the 1989 TRADOC CAS-assumption organization previously discussed. Figure 17 is the author's proposed wire diagram for the AATR.

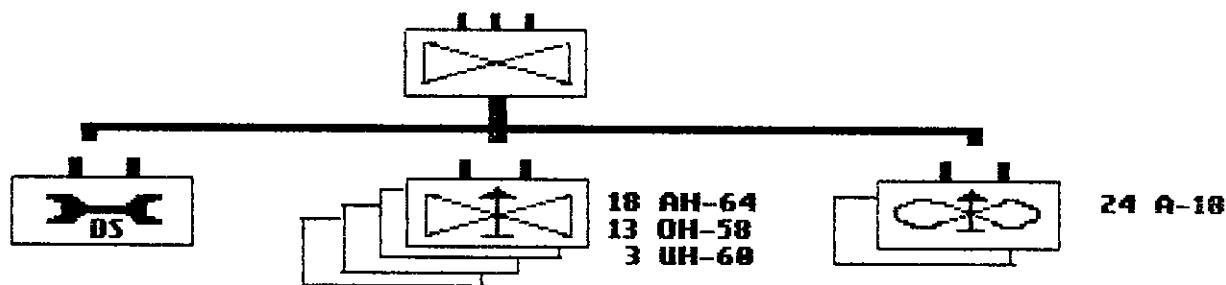

Figure 17
THE CORPS AIR ATTACK TEAM REGIMENT

Each regiment will have two A-10 squadrons of 24 aircraft each. These would be teamed with two-to-four attack helicopter battalions, and the organization would have its own organic DS maintenance support unit. The entire organization would be under the command of the regimental commander, an O-6, who is subordinate to the CAB commander. During peacetime the CAB commander is an O-6, but is authorized to be an O-7 during combat. This option has the Air Force retaining authority and control of the CAS mission. The AJAAT is defined as air maneuver, not CAS, and is therefore an Army mission.

THE PLANNING PROCESS

This organization offers several advantages in the AJAAT planning process. Like the TRADOC option, the corps commander now controls all the elements of the AJAAT. Corps allocates AJAAT task forces directly to subordinate units.

The planning for corps-level missions would be conducted by the AATR with input from the A-10 and AHB units. The planning for division and maneuver brigade AJAAT missions would also be initiated at the AATR, and then be finalized at the supported unit. This finalized planning would be between the task force and the supported unit, and would encompass all the normal coordination such as artillery, AD, and intelligence. The ground commander deals directly with one commander who controls the air maneuver assets of the AJAAT.

The planning coordination between the Air Force and Army that was conducted by the TACP is now conducted by the AATR. The TACP is free to concentrate on CAS-only missions that are requested and allocated as with current doctrine.

Immediate AJAAT Planning

Immediate-AJAAT mission planning would not change appreciably at the corps, division, or brigade. Their mission analysis would identify contingencies, and assets would be allocated to address those contingencies. Contingencies requiring air maneuver assets could be requested from corps as a complete package, and would be allocated with little fear of having the A-10 re-routed because of immediate CAS requests.

Immediate AJAAT will continue to be the method most often used to defeat penetrations in friendly defenses. The AATR offers the corps commander several options. Immediate requests for AJAAT or CAS would still follow present procedures. The difference is that the corps commander can either use his own AATR force, redirect allocated CAS sorties, or request additional CAS assets from the theater commander.

The AATR task force now has the ability to preplan operations that they may jointly participate in versus trying to conduct coordination over the radio during the battle. The AATR rear command post would be located at the corps airfield with the A-10 squadrons. The AHB's would also be located either on or in close proximity to the airfield. The corps

airfield would be located closer to the front than the present A-10 bases. This increases the A-10 flexibility and station time and reduces their response time. It will also increase their vulnerability, and the length of logistic lines.

An in-depth analysis of the potential battle area, threat, and missions can now be conducted by the entire AJAAT before the operation. This elevates Immediate-AJAAT planning to nearly the level of preplanned operations which can only improve the overall effectiveness of the AATR.

COMMAND AND CONTROL

Command and control is greatly facilitated under the AATR concept. Under current doctrine, once the battle is jointed, the AHB commander controls the AJAAT, and reports directly to the supported commander. As has already been shown, in an Immediate-AJAAT the AHB may enter the fight alone because of the lack of CAS assets or the distance they must travel. The AATR differs from that concept in that it sends task forces to the fight as a package under the C² of one commander. The supported commander still deals with only one individual commander, but that one commander has control of all the assets needed for air maneuver.

EXECUTION

The execution of AATR operations are envisioned to be the strength of the organization. Revisiting the typical scenario, the AHB moved into its attack position and awaited the arrival of the enemy and the A-10 aircraft. During the wait the AHB would establish contact with an AFAC who would hand control of the A-10's to the AHB. The AATR task force would function differently. It arrives at the battle as a team, and can immediately begin combat. The need to establish identity through authentication, or conduct air-to-air prebriefings is eliminated because the AATR functions without the need of an AFAC. Intelligence updates or mission alterations received while enroute are received by every aircrew negating the need for the AJAAT brief upon arrival at a preselected IP.

The commander of the task force controls movement of all aircraft to and from the battle area. The AATR task force commander knows the weapons loads, and available station time. Using standard AJAAT tactics, he sequences A-10 and Apache aircraft into the battle to provide continuous pressure, maximum destruction, or a combination of the two. The AFAC would still conduct CAS operations in support of ground assets, assuming the AD threat is eliminated or significantly reduced.

Deep operations are also enhanced by the AATR. The Apache has been the corps commander's deep maneuver asset since its deployment. Synergizing the elements of the AATR

provides the deep battle unprecedented capabilities under the command of one individual. This deep-AJAAT capability was demonstrated during the first night of combat of Operation DESERT STORM. Unclassified reports indicated that several Apache battalions were involved in deep AJAAT operations with A-10 units that resulted in the destruction of an Iraqi division.²⁷

TRAINING

The facet that will improve the lethality, versatility, and survivability of the AATR is its ability to consistently train as a team. With the addition of the A-10 squadrons into the AATR, Apache and A-10 commanders can establish face-to-face working relationships, develop SOP's that streamline employment procedures, conduct tactical training exercises at a much higher frequency than before, and conduct gunnery training as a team to name just a few.

Training as a team often leads to new doctrinal employment techniques that enhance the teams capabilities. Two of these techniques that would most assuredly occur are in the counter-air role, and night AJAAT operations, which are currently weaknesses.

Training together will reduce the amount of radio transmissions required. This reduces the radio signature of the team and reduces their susceptibility to electronic warfare; therefore, increasing their survivability.

SUMMARY

This chapter has focused on the comparison of three options for the integration and employment of the AJAAT in the Army. The comparison centered on four key elements; the planning process, command and control, execution, and training. The compilation of the chapter is presented in figure 18. Each option was assessed a relative value of either 1, 2, or 3 with 1 being the best and 3 being the least desired. The values were totaled, and the option with the lowest total was selected as the most viable based on the author's criteria.

CRITERIA		OPTION 1 STATUS QUO	OPTION 2 CASB	OPTION 3 AATR
PLANNING	Preplanned	3	2	1
	Immediate	3	2	1
COMMAND AND CONTROL		2	2	1
EXECUTION		2	3	1
TRAINING		3	2	1
Totals		13	11	5

Figure 18
SUMMARIZED OPTION ANALYSIS

FM 90-21 states unequivocally that preparatory planning is a major deficiency in current AJAAT operations. Centralizing the planning at one level and under one commander would enhance the planning step in the operation. Current AJAAT/JAAT doctrine tends to focus planning at the maneuver brigade level. That centralizes the planning responsibility too far down to allow effective use of planning time by the elements that have to execute the mission. Planning should be centralized as high as possible.

The same comment can be made of the TRADOC study. The assumption of the CAS mission puts increased demands on the corps staff, again sending AJAAT planning lower than is optimal.

The Air Attack Team Regiment can conduct the planning necessary for all AJAAT operations. The CAB would assist with future operations planning, and allow the AATR to focus on the current battle.

Command and control differences are not nearly as evident as the differences in the planning process. The TRADOC option and the AATR provide the most capabilities over current doctrine. The AATR offers the greatest flexibility because it doesn't have the competing missions that the TRADOC option does. The AATR commander would task organize his force package to fit the mission, and allow the greatest flexibility in the plan.

The execution comparison offers the most convincing evidence for the AATR concept. The AATR comes to the fight as a package and remains that way until mission completion. It provides solutions to every major deficiency identified concerning AJAAT operations.

The CASB option offers substantial benefits over current doctrine for conducting AJAAT, but those benefits may be outstripped by the difficulty it creates in conducting pure CAS. The increased competition for aircraft assets to conduct AJAAT and CAS could strain the limited asset corps would own. The result would be the loss of support somewhere on the battlefield. Augmentation by Air Force CAS aircraft could fill the shortfall. Requesting these assets would require the same process that is presently in place. The unknown quantity is whether or not the Air Force would allow Army AFAC's and GFAC's to control their aircraft during CAS missions. They do not allow that under current doctrine.

A possible deficiency in the AATR concept would be the potential loss of hundreds of A-10's on the battlefield. The four corps commands would have a maximum of 192 A-10's between them which leaves over 400 uncommitted.

"Train as you're going to fight," has been a phrase used extensively over the past few years. Its meaning is also reticently clear. Training is the cornerstone for any organization, particularly combat maneuver forces. The AATR concept offers the corps commander the ability to consistently train

AJAAT operations throughout the depth of his battlefield. Current doctrine, and to some extent the TRADOC option, have too many competing priorities to allow them to focus on AJAAT operations.

The major differences between the AATR and the TRADOC option are that the AATR is not responsible for CAS missions, and the A-10's and Apaches are under the same O-6-level commander. These two differences are significant enough to select the AATR over the TRADOC option. As the scores indicate, the TRADOC option offers little improvement over current doctrine, while creating its own special problems.

CHAPTER 4 ENDNOTES

1. U.S. Department of the Army, FM 100-5, Operations, (U.S. Government Printing Office, Washington D.C., May 1986), 15.
2. Center for Army Lessons Learned, Ft. Leavenworth, Ks., Observation #3899, May 5, 1988.
3. U.S. Department of Defense, FM 90-21 Multi-Service Joint Air Attack Team Operations (September 1990), (U.S. Government Printing Office, Washington D.C.), p. 2-1.
4. U.S. Department of the Army, FM 71-100 Division Operations, (U.S. Government Printing Office, June 1990), p. 6-19; and FM 71-2, Armored and Mechanized Infantry Brigade, (U.S. Government Printing Office, 11 May 1988), pp. 6-4 to 6-5.
5. U.S. Department of the Army, FM 100-5 Corps Operations, (U.S. Government Printing Office, September 1989), no page.
6. James A. Kelley and Alan K. Huffman, "JAAT Planning: Getting the Most From Synchronized Forces," Field Artillery Journal, (February 1988), 36.
7. FM 90-21, p. 2-4.
8. Center for Army Lessons Learned, Ft. Leavenworth, Ks., Observation #1360, March 4, 1986, Exercise BOLD EAGLE AAR, p. 11-A-5.
9. Kelley and Huffman, p. 37.
10. Center for Army Lessons Learned, Ft. Leavenworth, Ks., Observation #224, March 15, 1988.
11. The author conducted extensive research at CALL, and found very little data on file that dealt with JAAT/AJAAT operations.
12. FM-90-21, p. 2-3.
13. U.S. Department of the Army, FM 1-111 Aviation Brigade, (U.S. Government Printing Office, Washington D.C., August 1986), p. 8-3.
14. FM 90-21, p. 2-1.
15. FM 1-111, p. B-1.
16. Ibid., p. B-3.

17. Kelley and Huffman, 37.
18. U.S. Command and General Staff College, Ft. Leavenworth, Ks., Student Text 100-3 Battle Book, (Published by the Center for Army Tactics, 1 April 1989), p. 10-1.
19. Center for Army Lessons Learned, Ft. Leavenworth, Ks., Observation #259, June 16, 1987.
20. Operational Test Plan Concept for Evaluation of Close Air Support Alternative Aircraft, Office of the Secretary of Defense, (31 March 1989), i.
21. Ibid.
22. U.S. Army Assumption of Close Air Support Concept, Position Paper prepared by the Combined Arms Center, Ft. Leavenworth, Ks., for the Training and Doctrine Command, (1989), 12. Hereafter referred to as the "TRADOC Study."
23. Ibid., 14.
24. Ibid., 5.
25. Ibid., 14.
26. Center for Army Lessons Learned, Ft. Leavenworth, Ks., Observation #2287, October 29, 1986.
27. Telephonic interview conducted by the author with CW4 Gordon Lester at Ft. Rucker, Al. 25 January 1991.

CHAPTER 5

CONCLUSIONS AND RECOMMENDATIONS

The purpose of this thesis is to prove that the best place to incorporate the A-10 into the Army is in an Air Attack Team Regiment at corps-level. In the course of this endeavor, many other conclusions have surfaced that are noteworthy. Most of the conclusions are neither earth-shattering, nor are they new. They are logical and represent a perspective from the level of a potential user of the end-product.

CONCLUSIONS

The corps combat aviation brigade is the optimum location for the inclusion of the A-10 into the Army. Within the CAB, A-10 units should be organized with attack helicopter units to allow optimization of planning and execution, command and control, and training for AJAAT operations. The Air Attack Team Regiment (AATR) offers the corps commander the best choice for an AJAAT force structure.

JAAT/AJAAT operations are and will continue to be a viable combat mission. From the inception of the JAWS tests to current combat operations in Operation DESERT STORM, the AJAAT has proven to be a devastating force. The members of the team, Army attack helicopters and Air Force CAS aircraft, are many times more lethal and survivable when employed together rather than separately.

The A-10 is and will continue to be a potent, survivable aircraft on the low-to-mid intensity battlefield throughout its service life. Joint tests, and most recently unclassified evidence from Operation DESERT STORM, indicate that when properly employed, the A-10 is a devastating, flexible, and survivable platform.

The A-10 is a sustainable aircraft. The maintenance structure that currently exists in the Air Force is able to maintain the simplistic A-10 at extremely high operational rates. Transferring the equipment and training base along with the aircraft will ensure continued high availability rates.

Classic Close Air Support (CAS) using fixed-wing aircraft is and will continued to be an Air Force mission. JAAT/AJAAT, on the other hand, using attack helicopters and A-10 aircraft is air maneuver, and is an Army mission. The history of the CAS issue has spawned the growth of the attack helicopter, and ultimately the JAAT/AJAAT concept, but at the expense of Air Force credibility within the Army.

AJAAT operations are not addressed in sufficient detail in current Army doctrinal literature. The Army corps, division, and maneuver brigade operations manuals are the commands that currently plan and conduct AJAAT operations, yet their doctrinal manuals provide insufficient depth to allow adequate planning. The joint JAAT manual, FM 90-21, had been in the

"approval draft" stage since 1989. Actual release finally occurred in September 1990. The fact that there is a serious lack of material published makes the publication and distribution of FM 90-21 sine qua non.

The Third World Threat to the AJAAT is vast in terms of armor, air defense, and air forces. Despite the proliferation of modern systems, the AJAAT has proven its ability to conduct combat operations against the Threat, and succeed.

RECOMMENDATIONS

The author would be sadly mistaken if he thought his work would be the final word for incorporating A-10 aircraft into the Army. There is a significant amount of work that remains. This work focused on where to put the A-10, and in what type of organization. This leads directly into the author's recommendations.

A joint Army and Air Force formal force integration program should be initiated immediately. If Congress does not repeal the law that transfers some A-10's to the Army, the Army will be caught "flat-footed" without a plan for handling the aircraft transfer. Additionally, the personnel and logistical questions will have to be raised and ultimately answered. Will Air Force A-10 pilots come to the Army as part of the transfer, or will the Army have to field their own from the current force structure? These are just some of the personnel questions that will have to be resolved, and very soon.

APPENDIX A

REVIEW OF LITERATURE

A variety of primary and secondary sources were used to construct this thesis. These sources can be grouped into two broad categories: government documents (which includes Doctrinal Manuals, Congressional testimony, and test results), and personal interviews. Additionally, the author's personal experiences as an Army Attack Helicopter Company Commander, and Attack Helicopter Battalion S-3 were used as support.

PRIMARY SOURCE MATERIAL

GOVERNMENT DOCUMENTS

Government documents are divided into four subgroups. These subgroups are: Congressional testimonies and actions, Defense Department tests, historical studies, and doctrinal sources.

HISTORICAL STUDIES

The vast majority of chapter 1 is devoted to the development of the CAS controversy between the Army and Air Force. The primary source for examining and analyzing the history of the CAS issue was an Air Force-initiated paper titled "Army-Air Force Relations: The Close Air Support Issue," written by Goldberg and Smith. Originally a classified document, this Rand Corporation study conducted an in-depth historical review of all the pertinent DOD and congressional actions that were involved in the CAS controversy from 1943 until 1971. A key finding of the report was that the Army,

because of their desires to own and control their own CAS assets, and the Air Force's reluctance to perform the mission, had established a permanent role for themselves in the CAS arena.

After-action-review (AAR) comments from the Center for Army Lessons Learned (CALL) library were used extensively in chapter 4. These few AAR comments represent the totality of data dealing with JAAT operations that currently exist on file. These documents are considered as primary source because of the review process they underwent to be published in an Army-read document. Some comments are controversial, but they represented current doctrinal thinking within the Army at the time they were generated.

CONGRESSIONAL ACTIONS

Post-1971 Congressional testimony by key members of the Army, Air Force, and Congress supported the Goldberg and Smith findings. Testifying before Congress in 1972, Air Force Chief of Staff General Momyer concluded that the Air Force had failed to adequately support the Army, and they were in danger of losing the CAS mission completely.

Recent Congressional actions that are the foundation of this thesis are 1989 Public Law 100-256, which initiated the 1989 TRADOC CAS study, and 1990 HR 4739 which directed the transfer of A-10 aircraft to the Army.

Public Law 100-256 required the Army to examine the possibility of accepting the entire CAS mission from the Air

Force. TRADOC was the Army proponent for the study, and they introduced the Close Air Support Brigade (CASB). The study concluded that transferring the entire CAS mission was not in the best interests of the Army. The study did not address accepting only a portion of the CAS mission, principally because it was not in the study's charter. The Aviation Branch leadership at Fort Rucker echoed the sentiment of the TRADOC study. They wanted the Army to pursue the development of a tilt-rotor aircraft to conduct the CAS mission.

The passage of HR 4739 in 1990 is the most important legislation that impacts this thesis. Congress directed the transfer of A-10's into the Army on an equal basis for every OV-1 MOHAWK retired. The legislation also stipulated that the 30mm cannon on the A-10 remain installed and functioning. What the law did not stipulate is what mission the A-10 would perform. The OV-1 is an electronic warfare/reconnaissance aircraft. The A-10 presently has no capability of conducting either of the OV-1 missions. Also worthy of note is the complete surprise that the legislation created in the services.

TESTS RESULTS

Tests used as primary sources included the Joint Attack Weapons System Tactics Development and Development (JAWS TD&E) I, II, the Tactical Aircraft Survivability and Effectiveness in Close Air Support (TASVAL) test, and the A-10 Joint Air Attack Team with Improved Helicopters Tactics Development and Evaluation test (Advanced JAAT).

The JAWS test series established the JAAT concept. The results indicated that Army attack helicopters (AH-1's) and Air Force A-10's could dramatically increase their lethality and survivability when they combined their attacks into a JAAT.

TASVAL, which was really the third in the JAWS test series, was conducted to determine the JAAT team's effectiveness in an electronic warfare environment. Test results again established the viability of the JAAT concept.

The Advanced JAAT test was conducted to develop employment procedures for a AH-64 and A-10 JAAT structure. The test concluded that the AH-64/A-10 JAAT significantly increased the A-10 stand-off ranges, improved target acquisition, and greatly increased survivability on the mid-intensity battlefield. This test occurred at a critical juncture in the life of the A-10. The Air Force was in the process of selecting a successor to the A-10, because it wasn't thought to be survivable or effective on the current battlefield.

DOCTRINAL SOURCES

The only current source for the conduct of JAAT operations is FM 90-21, JAAT Operations, a multi-service manual. It identifies procedures currently used in planning JAAT operations, but does not provide the level of detail necessary to effectively execute the plan. It does identify that the planning phase of JAAT operations is the most difficult to perform.

A review of Army Manuals FM 71-3 Brigade Operations, FM 71-100 Division Operations, and FM 100-15 Corps Operations, identified a lack of serious discussion of JAAT operations. The inability to effectively synergize this asset into the ground commander's scheme of maneuver is at least partly due to the inability of staffs to plan this operation.

The operator's manuals for the AH-64 and A-10 served as the basis for background data in chapter 3. These manuals identified aircraft limitations, equipment, and ordnance carried by each aircraft.

The author considers Edward Bavaro's articles that appeared in Aviation Digest as primary source material. Bavaro, an award winning author assigned to the Army Aviation Center's Threat Branch, is an expert in the area of threat doctrine and his articles formed the basis for chapter 2.

The three articles used were: "Threat: Closing the Window"; "Threat: Running the Gauntlet"; and "Soviet Helicopter Air-to-Air." Each article deals with Soviet air defense weapons and capabilities, and how Army attack helicopters

could successfully operate against the threat. Bavaro also used material from the leading Soviet Helicopter tactician, General Belov, to develop his theories.

PERSONAL INTERVIEWS

Personal interviews comprised a major portion of the analysis of the strengths and weaknesses of the AH-64 and A-10 in chapter 3. Persons interviewed included two Apache battalion commanders, an Apache-qualified Naval Test Pilot School graduate, an A-10 Operations officer, an A-10 maintenance chief, and several pilots qualified in each aircraft. Data gained from these interviews was not available in any other source. This included first-hand test results of the 2.75 inch FFAR on the Apache, A-10 maintenance statistics, and overall pilot impressions of their aircraft.

The telephonic interviews conducted with Air Force Times correspondent Casey Anderson were invaluable. It was Anderson's article, "Close Air Support: A-10 or A-16?," that led the author to contact him. He provided the names of congressional supporters of HR 4739, and the initial details of the Senate bill that introduced that legislation.

SECONDARY SOURCE MATERIAL

Secondary source material fell into two categories: periodical literature and unpublished theses and papers.

UNPUBLISHED THESES AND PAPERS

Many theses used dealt with CAS or CAS-related issues. These included Thomas Monforte's, "Contemporary CAS: Problems and Prospects"; William Backlund's "Can the Army Take Over CAS with its Organic Aircraft"; and Kevin G. Kenkel's, "The Interim Close Air Support Aircraft."

Mullendore concluded that both the JAAT and CAS should become an Army mission with the fielding of the AH-64. His conclusion is echoed by Backlund who contends that the AH-64 is a better CAS platform than the A-10. Brigadier General John Bahnsen, a staunch supporter of Army Aviation, strongly agreed with both authors. In his article, "A New Army Air Corps or a Full Combat Arms Team Member," Bahnsen concluded that the Air Force should relinquish the CAS mission to the Army to include money and spaces with the fielding of the Apache. All three authors are Army officers, and exhibited prejudice toward their branch. All of the authors failed to examine the capability of JAAT, and they failed to examine the possibility of combining those assets into a permanent organization.

PERIODICAL LITERATURE

Brooke Nihart published several articles in Armed Forces Journal, between 1970 and 1971 that provided support for the background investigation in chapter 1. The three articles used; "Packard Panel Gets Off to Slow Start"; "Packard Review Group: Roles and Missions to Remain Untouched, Aircraft Systems to be Scrutinized"; and "Sixty Years of Unresolved Problems," provided a wealth of supporting material about the CAS issue. His articles were well researched, and led the author to many additional sources of data.

Other authoritative publications used included the Jane's-series of books. Jane's is considered a credible, non-classified source of data. Volumes used included the "Land-Based Air Defense", and "Armour and Artillery." These references provided unclassified material about Threat air defense systems for use in chapter 2.

Two sources were used to support the author's contention that the Apache is sustainable. A 1989 GAO study title, "Apache Helicopter, Serious Logistical Support Problems Must Be Solved to Realize Combat Potential," was very damning about the Apache maintenance problems. The study misrepresented the overall Apache readiness rate as only 50% Army-wide. Congressional testimony from Senator McClain in 1990 disputed the GAO study. McClain presented data from REFORGER exercises, and from OPERATION DESERT SHIELD, that showed the Apache readiness rates exceeded 80%. He also explained that the GAO study included the time period when two major Army posts with Apache

units were still recovering from major storm damage to their Apache fleets.

APPENDIX B

GLOSSARY

AAGS: Army Air-Ground System
AAR: After Action Review
AATR: Air Attack Team Regiment
ACC: Air Component Commander
ACM: Air Combat Maneuver
AD: Air Defense
ADC-M: Assistant Division Commander-Maneuver
AFAC: Airborne Forward Air Controller
AHB: Attack Helicopter Battalion
AI: Air Interdiction
AJAAT: Advanced Joint Air Attack Team
ALB: AirLand Battle
ALB-F: AirLand Battle-Future
ALO: Air Liaison Officer
AMU: Aviation Maintenance Unit
ASE: Aircraft Survivability Equipment
ASOC: Air Support Operations Center
ATHS: Automatic Target Hand-off System
ATO: Air Tasking Order
AVIM: Aviation Intermediate Maintenance

BAI: Battlefield Air Interdiction
BDA: Battle Damage Assessment

CAB: Corps Aviation Brigade
CALL: Center for Army Lessons Learned
CAS: Close Air Support
CASADA: Close Air Support Aircraft Design Alternatives
CASB: Close Air Support Brigade
C²: Command and Control
COSCOM: Corps Support Command
CP: Contact Point
CPG: Co-Pilot/Gunner

DOD: Department of Defense
DS: Direct Support

EACS: Enhanced Altitude Control System
ECM: Electronic Counter Measures
EPT: Emergency Procedures Training

FAC: Forward Air Controller
FARP: Forward Arming and Refueling Point
FFAR: Folding Fin Aerial Rocket
FLIR: Forward-Looking Infrared Radar
FLOT: Forward Line of Own Troops
FMC: Fully Mission Capable
FOV: Field of View

GCAS: Ground Collision Avoidance System
GFAC: Ground Forward Air Controller

GS: General Support
 G/VLLD: Ground/Vehicle Laser Locator Designator

ICT: Integrated Combat Turnaround
 IFV: Infantry Fighting Vehicle
 INS: Inertial Navigation System
 IRCM: Infrared Counter Measures
 JAAT: Joint Air Attack Team
 JAWS: Joint Attack Weapons System
 JCS: Joint Chiefs of Staff

LASTE: Low Altitude Safety and Target Enhancement
 LOAL: Lock-On After Launch
 LOBL: Lock-On Before Launch
 LNO: Liaison Officer
 LOS: Line-Of-Sight

MOA: Memorandum of Agreement
 MOU: Memorandum of Understanding
 MRD: Motorized Rifle Division
 MRR: Motorized Rifle Regiment

NOE: Nap-of-the-Earth
 NTC: National Training Center

OPCON: Operational Control
 OR: Operational Readiness

PNVS: Pilot Night Vision System

R&D: Research and Development

SAM: Surface-to-Air-Missile
 SLAR: Side-Looking Infrared Radar
 SOP: Standard Operating Procedure

TAC: Tactical Air Command
 TACAIR: Tactical Air
 TACP: Tactical Air Control Party
 TACS: Tactical Air Control System
 TADS: Target Designation System
 TASVAL: Tactical Aircraft Survivability and Effectiveness in
 Close Air Support Anti-Armor Operations
 TFS: Tactical Fighter Squadron
 TFW: Tactical Fighter Wing
 TOW: Tow launched-Optically tracked-Wire guided
 TR: Tank Regiment
 TRADOC: Training and Doctrine Command
 TSU: Telescopic Sight Unit

VMC: Visual Meteorological Condition
 VTOL: Vertical Take-Off and Landing

BIBLIOGRAPHY

Government Publications

- Greenfield, Kent R. Army Ground Forces and the Air-Ground Battle Team Including Organic Light Aircraft. Fort Monroe, VA. Historical Section, Army Ground Forces Study No. 35. 1948.
- Goldberg, Alfred, and Smith, Donald. Army-Air Force Relations: The Close Air Support Issue. Special report for USAF Project Rand by the Rand Corporation. October 1971.
- "Military Implications of the Mi-24 Hind E Attack Helicopter." Defense Intelligence Agency. Technical Intelligence Report. 7 March 1983. SECRET. 49.
- Operational Test Plan Concept for Evaluation of Close Air Support Alternative Aircraft. Office of the Secretary of Defense. Washington. 31 March 1989.
- Reynolds, Scott A. A-10 Joint Air Attack Team With Improved Helicopters Tactics Development and Evaluation. Report from the 57th Fighter Weapons Wing. Nellis AFB, Nv. July 1987.
- "Soviet Air Defense in the ME." Report prepared by Assistant Chief of Staff for Intelligence for the U.S. Army Training and Doctrine Command. 1-6.
- Soviet Military Power: Prospects for Change. Washington: Government Printing Office. 1989.
- Tactical Aircraft Effectiveness and Survivability In CAS Anti-Armor Operations (TASVAL) Test Report-Vol 1, Executive Report. Director, Defense Test and Evaluation. Office of the USDR&E. Washington. 1980.
- "Threat to Army Aviation." Briefing by U.S. Army Intelligence Security Command and U.S. Army Intelligence and Threat Analysis Center. SECRET. December 1981. 8A-14B.
- U.S. Army Assumption of Close Air Support Concept. Position Paper prepared by the Combined Arms Center, Ft. Leavenworth, Ks, for the Training and Doctrine Command. 1989.
- U.S. Congress, Congressional Record. 101st Congress, 2nd Session. Vol. 136. 12 June 1990. Washington, D.C.: Government Printing Office, 1990.

- U.S. Congress, Defense Appropriations Bill HR4739. 101st Congress, 2nd Session. 4 November 1990. Washington, D.C.: Government Printing Office 1990.
- U.S. Department of the Air Force. Flight Manual for the A-10A Aircraft, T.O. 1A-10A-1. Washington: Government Printing Office. 20 February 1983 with change 1.
- U.S. Department of the Air Force. Tactical Air Command Regulation 66-5. Washington: Government Printing Office. 31 May 1985 with change 3. Chapter 9.
- U.S. Department of the Army. FM 1-111 Aviation Brigade. Washington: Government Printing Office. August 1986.
- U.S. Department of the Army. FM 1-112 Attack Helicopter Battalion. Washington: Government Printing Office. 14 July 1986.
- U.S. Department of the Army. FM 71-3 Armored and Mechanized Infantry Brigade. Washington: Government Printing Office. 11 May 1988.
- U.S. Department of the Army. FM 71-100 Division Operations. Washington: Government Printing Office. 16 June 1990.
- U.S. Department of the Army. FM 90-21 JAAT Joint Air Attack Team Operations. Washington: Government Printing Office. September 1990.
- U.S. Department of the Army. FM 100-5 Operations. Washington: Government Printing Office. 13 September 1989.
- U.S. Department of the Army. FM 100-15 Corps Operations. Washington: Government Printing Office. 13 September 1989.
- U.S. Department of the Army. Operator's Manual for the AH-64A Helicopter TM 55-1520-238-10. Washington: Government Printing Office. 28 June 1984 with change 12.
- U.S. Department of Defense. Directive Number 5160.22. Clarification of Roles and Missions of the Departments of the Air Force Regarding Use of Aircraft. Washington D.C.: Government Printing Office. 18 March 1957.
- U.S. Department of Defense. Joint Chiefs of Staff Publication JCS Pub 1-02, Dictionary of Military and Associated Terms. Washington: Government Printing Office. 1 December 1989.

U.S. General Accounting Office. "Apache Helicopter, Serious Logistical Support Problems Must Be Solved to Realize Combat Potential." Report to Congressional requestors. Washington D.C.: Government Printing Office. September 1990.

U.S. House of Representatives. Department of Defense Appropriations for 1979. Hearings before the Subcommittee of the Committee on Appropriations, 95th Congress, 2nd Session, Part 5. Tactical Aircraft. Washington: Government Printing Office. 1978.

U.S. Senate. S2284, National Defense Authorization Act for Fiscal Year 1991. 101st Congress, 2nd Session. July 20 1990. Washington: Government Printing Office. 245-246.

Books

Chant, Christopher. Air Defense Systems and Weapons World AAA and SAM Systems in the 1990's. Brassey's Defense Publishers. Washington, D.C. 1989. 196-200.

Cordesman, Anthony H. and Wagner, Abraham R. The Lessons of Modern War, Volume I: The Arab-Israeli Conflicts, 1973-1989. Westview Press. Boulder, Co. 1990. 73-82.

Davis, Richard G. The 31 Initiatives: A Study in Air Force-Army Cooperation. Historical Study for the Office of the Air Force History. Washington: 1987.

Hadley, Arthur T. Straw Giant: America's Armed Forces Triumphs and Failures. Avon Books. New York. 1986. 112-113.

Jane's Armour and Artillery, 1989-90. 10th Edition. Edited by Christopher F. Foss. 85-91.

Jane's Land-Based Air Defense 1989-90. 2nd Edition. Edited by Tony Cullen and Christopher F. Foss.

Keegan, John. World Armies. 2nd Edition. Gale Research Company. 1983.

MacIsaac, David. "Voices from the Central Blue: The Air Power Theorists." In Makers of Modern Strategy from Machiavelli to the Nuclear Age. Edited by Peter Paret. Princeton, New Jersey: Princeton University Press. 1986.

Articles

- Ahearn, David L. "Beans and Bullets for Apache Deep Attack." Army Logistician. (March-April 1990): 2-5.
- Anderson, Casey, "Close Air Support: A-10 or A-16?". Air Force Times. (Oct 15, 1990): 28.
- Bahnsen, John C. BG (Ret). "A New Army Air Corps or a Full Combat Arms Team Member." Armed Forces Journal International. (October 1986): 62-80.
- Bavaro, Edward J. "Soviet Helicopter Air-to-Air." U.S. Army Aviation Digest. (March 1988): 2-8.
- Bavaro, Edward J. "Threat: Closing the Window." U.S. Army Aviation Digest. (January 1986): 10-15.
- Bavaro, Edward J. "Threat: Running the Gauntlet." U.S. Army Aviation Digest. (October 1986): 30-34.
- Belov, M., Colonel. "How to Fight Helicopters." U.S. Army Aviation Digest. (October 1981): 20-22.
- Berry, F. Clifton, Jr. "JAWS-Chew Armor in New Ways; Army-Air Force Tests Devise Winning Tactics." Armed Forces Journal International. (January 1978): 32-34.
- Bingham, P.T. "Dedicated CAS: A Bad Idea." Armed Forces Journal. (September 1987): 58-60.
- Blackwell, James A. Dr. "American Close Air Support-The Next Model." NATO's Sixteen Nations. Vol 33 No. 8. (Dec 88-Jan 89): 56-61.
- Brunelle, Ron and Mooney, Phillip A. "AH-64: A Total System for Battle." U.S. Army Aviation Digest. (September 1986): 36-45.
- Budiansky, Stephan; Robbins, Carla Anne; Auster, Bruce B.; and Cary, Peter. "The Lessons of Desert Shield." U.S. News and World Report. (September 10, 1990): 36-40.
- Cannet, Maurice. "Air-to-Air Fighting With Helicopters." International Defense Review. Vol 21. (August 1988): 953-956.
- Clontz, William R. "Wildcard on the Battlefield." U.S. Army Aviation Digest. (January 1988): 2-7.

- Cook, Charles B., Dickens, Fred W., and Wilson, Croften B. "Integrating Army Aviation and Forward Area Air Defense in the Counterair Mission." U.S. Army Aviation Digest. (October 1987): 2-5.
- Dermer, Phillip J. "JAAT EAGLE 87." U.S. Army Aviation Digest. (August 1988): 32-36.
- Ferrell, Mark and Reynolds, Scott. "Apache Thunder." U.S. Army Aviation Digest. (May 1989): 2-10.
- Forshag, Russel S. "Culminating Points in Aviation Operations." U.S. Army Aviation Digest. (Jan/Feb 1990). 36-42.
- Fulghum, David. "Congress Holds Air Forces Favorite Fighter Hostage." Air Force Times. (27 November 1989): 25-26.
- Fulghum, David. "Desert 'Combat'; The Closest Thing to Real War." Air Force Times. (23 April 1990): 14-15.
- Garrett, Thomas. "Close Air Support: Which Way Do We Go?" Parameters, U.S. Army War College Quarterly. (Vol XX, No. 4, Dec 1990). 29-43.
- Gibbs, George. "The Control of Close Air Support for the Ground Force." Asian Defence Journal. (May 1987): 44-50.
- Gilson, Charles. "Can the A-10 Thunderbolt II Survive in Europe?". International Defense Review. Volume 12. (No 2/1979): 184-206.
- Gonseth, Jules E. "Tactical Air Support for Army Forces." Military Review. (July 1955): 6-16.
- Hirsch, Norman B. "AH-64: A Total System for Battle." U.S. Army Aviation Digest. (July 1986): 3-9.
- Kelly, James A. and Huffman, Alan K. "JAAT Planning: Getting the Most From Synchronized Forces." Field Artillery. (February 1988). 35-38.
- Leaf, Daniel P. "The Future of Close Air Support." Military Review. (March 1989): 10-19.
- Mann, Dennis W. "TACS/AAGS. What is It? What Do Marines Need To Know About It?" Marine Corps Gazette. (October 1988. Vol 72. No 10) 56-59.
- "Major Combat Unit, U.S. Army." Army 1990-1991 Green Book. (October 1990): 252-254.

- Mazar, Michael. "The Light-Heavy Debate Rears its Ugly Head." Armed Forces Journal International. (October 1989): 97-100.
- McGinty, Kenneth R. "A-JAAT." U.S. Army Aviation Digest. (February/March 1987): 33-35.
- Niesters, Manfred. "Soviet Helicopter Doctrine." International Defense Review. (No 10/1987): 1321-1325.
- Nihart, Brooke. "Packard Panel Gets Off to Slow Start." Armed Forces Journal. (5 April 1971): 38-42.
- Nihart, Brooke. "Packard Review Group: Roles and Missions to Remain Untouched, Aircraft Systems to Be Scrutinized." Armed Forces Journal. (19 April 1971): 19, 39-40.
- Nihart, Brooke. "Sixty Years of Unresolved Problems." Armed Forces Journal. (25 April 1970): 19-26.
- Roger, J.B. "Synchronizing the Air-Land Battle." Military Review. (April 1986): 65-71.
- Russ, Robert D. "The Air Force, The Army in the Battlefield of the 1990's." Defense 88. (July/August 1988): 12-18.
- Ryan, John D. "Quality is the Key to Force Effectiveness." Air Force Magazine and Space Digest. (May 1970): 45.
- "SA-6 -Arab Ace in the 20-Day War." International Defense Review. Edited by R.D.M. Furlong. (Vol 6, No. 6, Dec 1973). 779-783.
- Saint, Crosbie E. and Yates, Walter F., Jr. "Attack Helicopter Operations in the AirLand Battle: Deep Operations." Military Review. (July 1988): 2-9.
- Saint, Crosbie E. and Yates, Walter F., Jr. "Attack Helicopter Operations in the AirLand Battle: Close Operations." Military Review. (June 1988): 2-15.
- Saint, Crosbie E. and Yates, Walter F., Jr. "Attack Helicopter Operations in the AirLand Battle: Rear Operations." Military Review. (October 1988): 2-10.
- "Squabbles Over the Warthog Successor." International Aviation. (February 1990): 151-152.

Tewes, Laura L. "The Israeli Air Force and the 1982 Lebanon War." U.S. Army Aviation Magazine. (July/Aug 1990): 60-65.

"USAF Aircraft-How Many, How Old?" Air Force Magazine. (May 1990): 48-49.

"Warthogs In Action." Defense Update International. No. 72. (July 1986): 27-30.

Watkins, Stuart H. and Barron, Michael J. "Air Maneuver on the Modern Battlefield." Military Review. (July 1989): 49-53.

Whitcomb, Darrel D. "Hogs in the Rear- A-10's in Rear Operations." Airpower Journal. (Winter 1988): 16-21.

Zaloga, Steven S. "The Su-25 Frogfoot", Jane's Soviet Intelligence Review. (5 Oct 1989): 461.

Unpublished Dissertations, Theses and Papers

Backlund, William V., Jr. "Can the Army Take Over CAS With its Organic Aircraft." Student Research Report, Air Command and Staff College, Maxwell AFB, Al. 1985.

Brandon, Thomas S. "It's Time To Decentralize Control of Close Air Support." Student Research Report, Air Command and Staff College, Maxwell AFB, Al. 1978.

Buhrow, Robert E. "Close Air Support Requirements: A Case of Interservice Rivalry." Military Study Program paper, U.S. Army War College, Carlisle Pa. 1 March 1971.

Burke, David K. "A-10 Effectiveness Against Soviet Offensive Operations in Central Europe." Masters Thesis, U.S. Army Command and General Staff College, Ft. Leavenworth, Ks. 1984.

Center for Army Lessons Learned. Observation #224. Ft. Leavenworth, Ks. 5 May 1988.

Center for Army Lessons Learned. Observation #259. Ft. Leavenworth, Ks. 16 June 1987.

Center for Army Lessons Learned. Observation #1360. Ft. Leavenworth, Ks. 4 March 1986.

Center for Army Lessons Learned. Observation #2287. Ft. Leavenworth, Ks. 29 October 1986.

Center for Army Lessons Learned. Observation #3899. Ft. Leavenworth, Ks. 5 May 1986.

Kenkel, Kevin G. "The Interim Close Air Support Aircraft- Is the A-10(+), A-7(+), or A-16 The Most Suitable for the High Threat Environment." Masters Thesis, U.S. Army Command and General Staff College, Ft. Leavenworth, Ks. 1990.

Knox, Raymond O. "High Speed Jets in a Low Speed War: The Utility of Tactical Airpower in Low-Intensity Conflict." Unpublished Monograph, School of Advanced Military Studies, U.S. Army Command and General Staff College, Ft. Leavenworth, Ks. 20 April 1989.

McClain, Stephen M. "Problems Associated With the Joint Air Attack Team." Masters Thesis, U.S. Army Command and General Staff College, Ft. Leavenworth, Ks. 1982.

Monforte, Thomas J. Jr. "Contemporary CAS: Problems and Prospects." Student Research Report, U.S. Army War College, Carlisle, Pa. 23 March 1987.

Mullendore, Lauren G. "The Future of the Joint Air Attack Team in the AirLand Battle." Student Research Paper, U.S. Air Force Air War College, Maxwell AFB, Al. 1989.

Rolfs, Lawrence L. "Joint Air Combat in the Close Battlefield." Masters Thesis, U.S. Army Command and General Staff College, Ft. Leavenworth, Ks., 2 April 1990.

Terrien, Max V. "Close Air Support: Retrospective And Perspective-Is the Helicopter the Answer." Masters Thesis, U.S. Army Command and General Staff College Ft. Leavenworth, Ks. 1982.

Interviews

Anderson, Casey. Congressional staff writer for Air Force Times. Interviews conducted telephonically October and December 1990.

Brazeal, Ernest. Senior Master Sergeant. USAFRES. Maintenance Team Chief, 402 Tactical Fighter Wing. Richards-Gebauer AFB. Interview conducted November 1990.

Burgess, Dewayne. Major. USAFRES. Operations Officer, 303 Attack Fighter Squadron, Richards-Gebauer AFB. Interview conducted November 1990.

Jernigan, Fred. Major. USA. Former Apache Company Commander and Squadron S-3 (Operations Officer). Ft. Leavenworth, Ks, November 1990.

Lester, Gordon R. CW4. USA. U.S. Naval Test Pilot Graduate. One of the first Army pilots qualified in the Apache. Worked in the Apache Program Manager Office during the Initial Fielding. Interviews conducted from July 1989 to July 1990 at the US Naval Test Pilot School, Patuxent River, Md.

Mitchell, Robert V. LTC(P). USA. Former Commander, 3rd Squadron, 6th Cavalry Regiment (Apache), Fort Hood, Texas. Interview conducted at the U.S. Army War College, Carlisle Barracks, Pa., in October 1989.

Powell, William. LTC. USA. Commander, 1st Squadron, 6th Cavalry Regiment (Apache), Fort Hood, Texas. Interview conducted at the Command and General Staff College, Ft. Leavenworth, Kansas, in October 1990.

Weaver, Stephen. MAJ. USAF. Former A-10 pilot; former Air Liaison Officer with the 11th Armored Cavalry Regiment. Interview conducted in November 1990 at the Army Command and General Staff College, Fort Leavenworth, Kansas where Weaver was a student. Weaver was also used as a reviewer for portions of chapters 3 and 4.

INITIAL DISTRIBUTION LIST

LTC Steven R. Baribeau
CTAC, CGSC
Fort Leavenworth, KS 66027

MAJ Billy Stephen, USAF
USAF Detachment
CGSC
Fort Leavenworth, KS 66027

COL Robert W. Duffer
7608 Pickard NE
Albuquerque, NM 87110

Mr. Casey Anderson
Air Force Times Staff Writer
Washington, D.C.

LTC Robert Heffley
AirLand Forces Application Agency
Bldg 714
Langley AFB, VA 23665-5557

MAJ Duane Burgess
442nd TFS
Richards Gebaur AFB, MO