

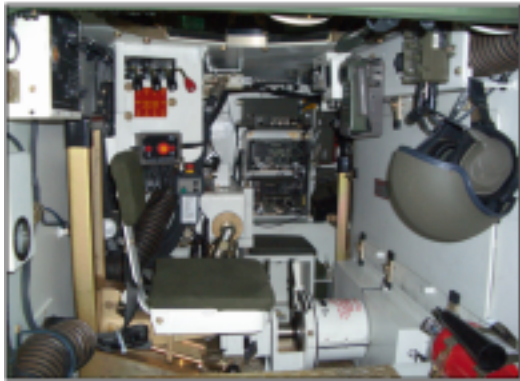

TRACKED LOGISTIC CARRIER

United Defense



- **PROTECTION AND SURVIVABILITY**
 - **CREW COMPARTMENT 14.5 mm AP**
- **FIRE POWER**
 - **COMMANDER'S CUPOLA WITH 12.7 mm MG**
 - **8 SMOKE GRENADE LAUNCHERS**
- **MATERIAL HANDLING CRANE**
- **SELF RECOVERY WINCH**
- **POWER TRAIN AND SUSPENSION SUB-SYSTEMS**
 - **COMMON TO M113A3**
- **COMBAT READY VEHICLE WEIGHT = 41,000 LB**
- **C130 TRANSPORTABLE**



- **CREW**
 - **BASIC CREW OF TWO (DRIVER AND COMMANDER)**
 - **JUMP SEAT PROVIDED FOR THIRD MEMBER**
- **ENVIRONMENTAL CONTROL**
 - **AIR-CONDITIONING**
 - **FACEMASK OR (OPTIONAL) OVERPRESSURE NBC**

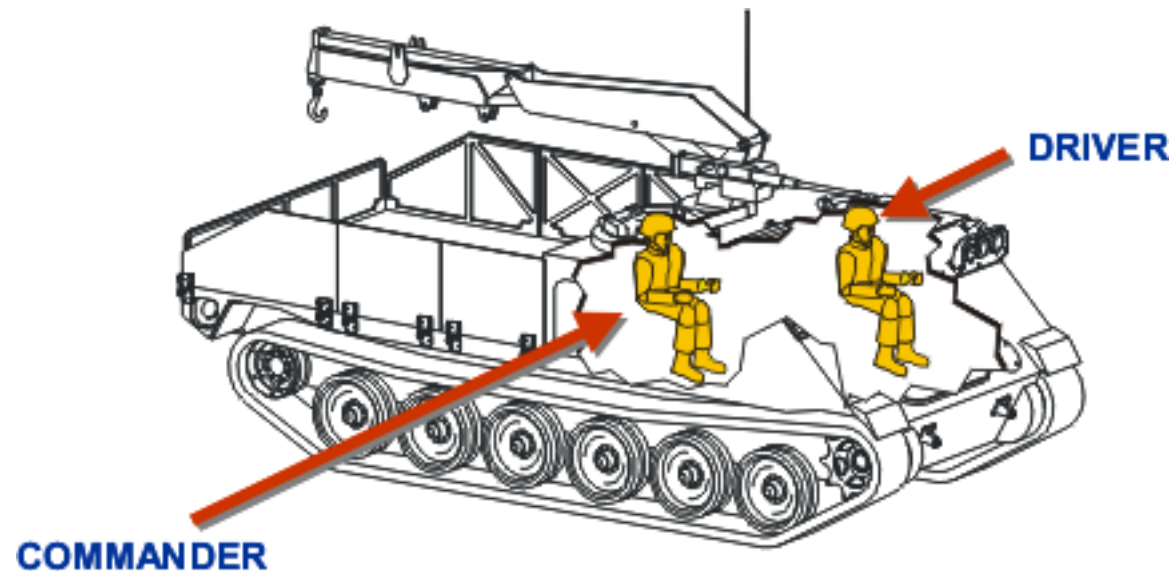

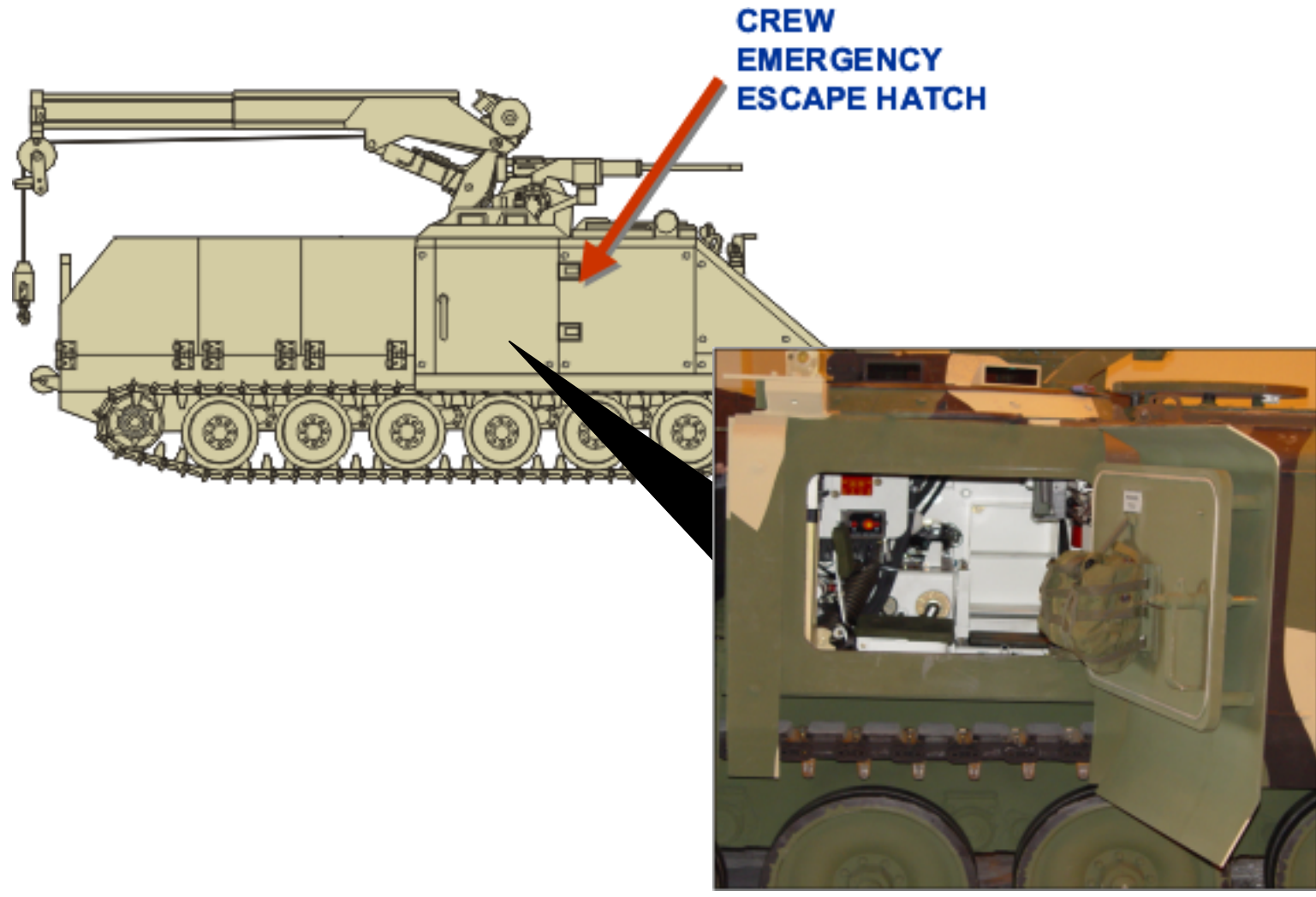



DRIVER COMPARTMENT

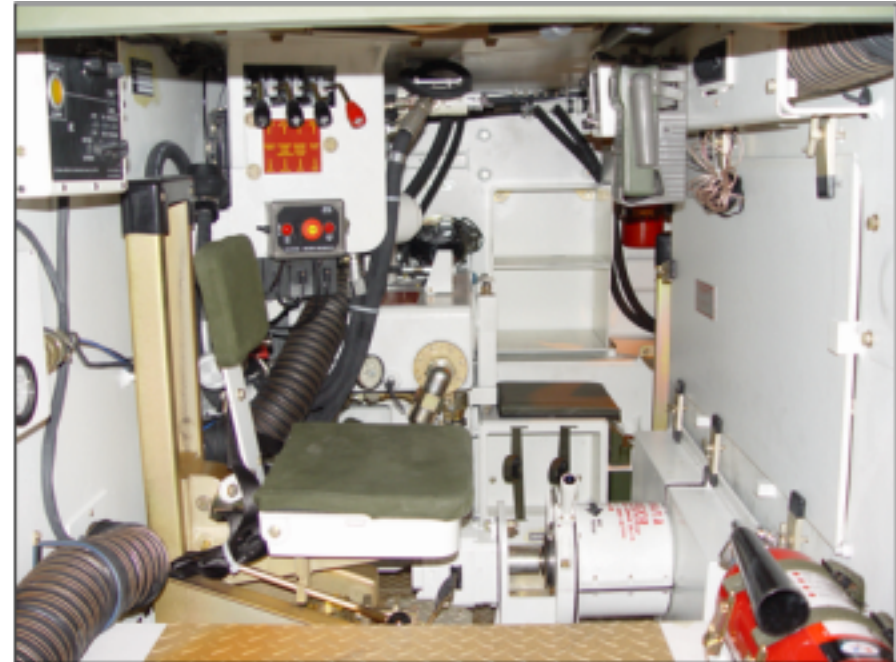

COMMANDER COMPARTMENT

- **CARGO CAPACITY (VOLUME)**
 - **FLAT BED AREA 98 in x 120 in (82 ft²)**
- **LOAD CAPABILITY**
 - **13,000 lb**
 - **CAPABLE OF CARRYING OVERSIZED LOADS WITH PANELS LOCKED DOWN**
- **155 MM AMMUNITION CAPACITY**
 - **6 PALLETS HE PROJECTILES OR**
 - **4 PALLETS HE PROJECTILES,**
 - **2 PALLETS FUSES**
- **OTHER LOGISTIC LOADS SUCH AS FUEL, WATER & RATIONS**
- **MBT/ACV POWER PACKS**



- **MAKE..... HIAB**
- **MODEL..... 172R**
- **CAPACITY.....1,600 kg**
- **ROPE LENGTH..... 13 m**
- **OPERATING ENVELOPE.....3.26 m**
- **REMOTE CONTROL UNIT....15 m**
- **ACTUATION..... HYDRAULIC**





REMOTE CONTROL UNIT



- **MAKE..... ROTZLER**
- **MODEL..... HZ 090, 100 KN**
- **PULLING FORCE..... 100 KN (10,197 kg FORCE)**
- **CABLE LENGTH..... 65 m**
- **TYPE OF DRIVE.....HYDRAULIC**

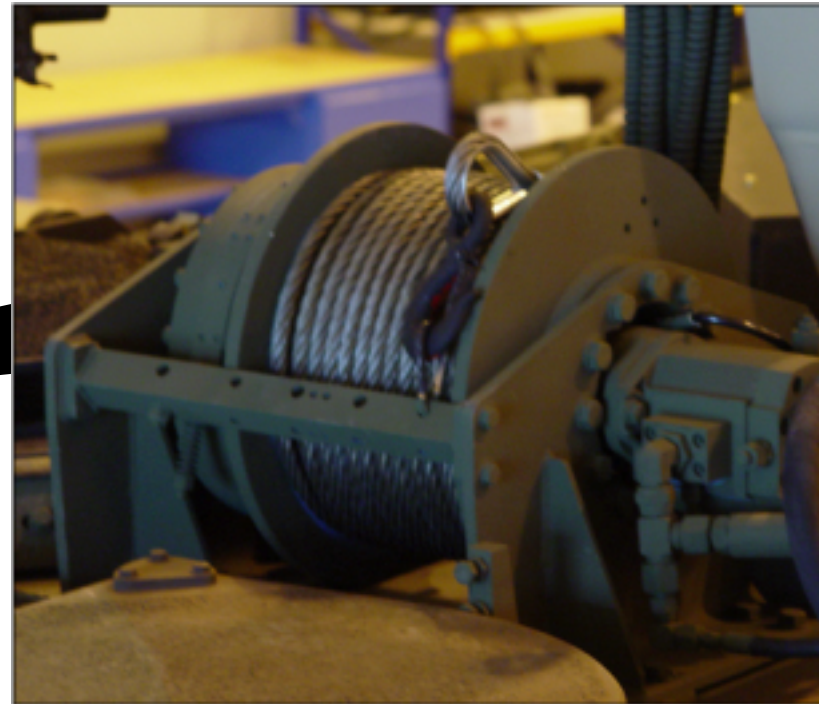
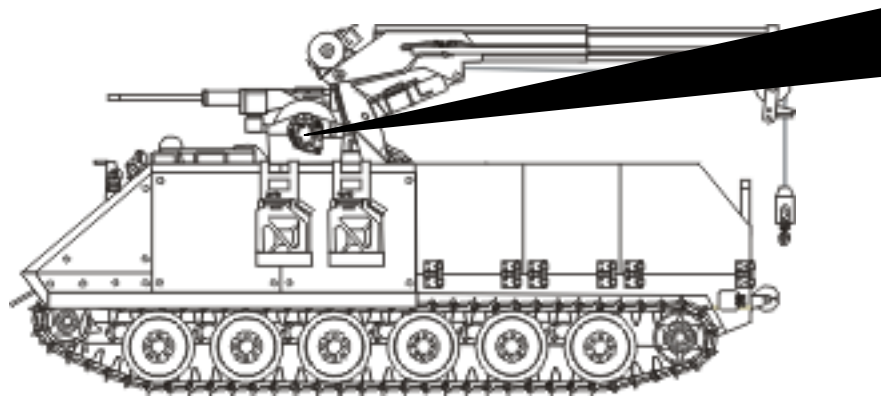



This document was created with Win2PDF available at <http://www.daneprairie.com>.
The unregistered version of Win2PDF is for evaluation or non-commercial use only.